

LFS | Kataloog 2011



# Karbikpaigaldussüsteemid

Tere tulemast klienditeenindusse

---

**Teeninduse telefon: 0 23 73 / 89-1500**

---

**Faks päringuteks: 0 23 73 / 89-77 77**

**Faks tellimuste esitamiseks: 0 23 73 / 89-77 55**

---

**E-post: [info@obo.de](mailto:info@obo.de)**

**Internet: [www.obo.de](http://www.obo.de)**



Kasutage OBO klienditeeninduse otsetelefoni! Teeninduse kiirühendusnumbril 02373/89-1500 oleme iga päev kella 7:30-st kuni 17:00-ni teie käsutuses, et vastata kõikidele küsimustele OBO tervikliku elektripaigalduse tootevaliku kohta. Uue sisekorraldusega OBO klienditeenindus pakub teile terviklikku tootevalikut:

- Kompetentne kontaktisik teie piirkonnas
- Kogu info OBO tootevaliku kohta
- Asjatundlik nõustamine erinevate rakendusvalade korral
- Kiire ja otsene juurdepääs kõigi OBO toodete tehnilistele andmetele – ka kliendiläheduselt tahame olla parimad!

## Sisukord

	Planeerimisabivahend	5
	WDK plastist juhtmestikukarbikusüsteemid	83
	LKM metallist juhtmestikukarbikusüsteemid	137
	SKL põrandaliistkarbikusüsteemid	157
	VK traadistuskarbikusüsteem, süsteem Dahl	163
	Seadmekarbik Rapid 45, plastsüsteemid	187
	Seadmekarbik Rapid45, alumiiniumsüsteemid	199
	Seadmekarbik Rapid 80 GK, plastsüsteemid	209
	Seadmekarbik 80 GS, terasplekksüsteemid	221
	GEK-A seadmekarbik, alumiiniumsüsteemid	267
	Seadmekarbikute tarvikud	305
	ISS karbikpostisüsteemid	317
	Seadmepaigaldus	339
	Registrid	361



### **OBO karbikpaigaldussüsteemide seminarid: teadmised algallikast**

Laiapõhjaline koolitus- ja seminariprogramm juhtmestikussüsteemide teemal toetab OBO kasutajaid algallikast pärit ekspertteadmistega. Lisaks teoreetilistele alustele räägitakse ka praktilisest kasutamisest igapäevaelus. Omandatud laialdased teadmised võetakse kokku konkreetsetes rakendus- ja arvutusnäidetes.

### **Tellimisvormid, tooteinfo ja andmelehed**

Teeme teie elu lihtsamaks. Tänu praktilas kasutamiseks ettevalmistatud materjalide rikkalikule valikule, mis toetavad teid projekti planeerimisel ja kalkuleerimisel tõhusalt juba algusest peale. Nende hulka kuuluvad:

- tellimisvormid
- tooteinfo
- teabelehed
- andmekaadid

Me uuendame neid dokumente pidevalt ja neid saab ööpäevaringselt veebilehelt [www.obo.de](http://www.obo.de) tasuta alla laadida.











### **Blankettide tekstid on Internetis saadaval:**

**[www.ausschreiben.de](http://www.ausschreiben.de)**

Tasuta saab alla laadida rohkem kui 10 000 kirjet valdkondadest KTS, BSS, TBS, LFS, EGS ja UFS. Tänu regulaarsele ajakohastamisele ja laiendamisele on teil alati olemas igakülgne ülevaade OBO toodetest. Seejuures on kasutatavad kõik levinumad andmeformaadid (PDF, DOC, GAEB, HTML, TEXT, XML, ÖNORM).

[www.ausschreiben.de](http://www.ausschreiben.de)

## Projekteerimis- ja montaažiabide sisukord

	Üldine projekteerimisabi	6
	WDK plastist juhtmestikukarbikusüsteemid	13
	LKM metallist juhtmestikukarbikusüsteemid	19
	SKL pörandaliistkarbikusüsteemid	23
	VK traadistuskarbikusüsteem, süsteem Dahl	27
	Seadmekarbik Rapid 45, süsteemiava 45 mm	35
	Seadmekarbik Rapid 80, süsteemiava 80 mm	41
	Seadmekarbikute tarvikud	53
	Karbikpostisüsteemid	59
	Seadmepaigaldus	65
	Täpsem info	75



## Juhtmestikussüsteemide ja metallist karbikpostide hõlmamine kaitsemeetmete hulka



### Olulisemad kaitseabinõud

Puudutatavad metallosad ei tohi ka rikke korral pinge all olla. Seetõttu tuleb rakendada vastavaid kaitseabinõusid. Need on sätestatud hetkel kehtivates normides. Juhtmestikussüsteemide loomise osas kehtivad sätted EN 50085-1 ja EN 50085-2-1, paigaldise osas kehtivad DIN VDE 0100 osade 410 ja 540 paigaldussätted (kaitsemeetmed ohtlike voolupingete vastu).

### Euroopa standardi kohased paigaldusviisid

Euroopa standard EN 50085-1 arvestab erinevate paigaldusviisidega, mida ELi liikmesriikides kasutatakse. Kui varem olid paigalduskarbiussüsteemide puhul ette nähtud üksnes potentsiaaliühtlustuskontrollid, siis nüüd nõutakse nimetatud standardites ka kaitsejuhi funktsiooni. See tuleneb sellest, et mõnes riigis tohib karbikutesse paigaldada baasisolatsiooniga juhtmeid.

### Kõik metallist komponendid peavad olema hõlmatud

Standard EN 50085-1 näeb ette: kaitsemeetmed peavad hõlmama kõiki metallist komponente. Vastavad kontrollimised peab tegema ja dokumenteerima tootja. OBO paigalduskarbid on lisaks katsetatud ja sertifitseeritud ka välise kontrollorgani VDE poolt.

### Toimimise kontrollimine paigaldaja poolt

Paigaldaja peab pärast paigalduse lõpetamist kontrollima kaitseabinõude toimimist vastavalt standardi DIN VDE 0100 osale 610. Kontrollida tuleb kontakt-

kruvide pingutusmomenti maandusklemmidel ning ühenduste õiget paigaldust.

### Läbivad kaitseabinõud

Karbiku katkestamisel seinaläbiviikudes on ette nähtud kaitseabinõu jätkumine, sest karbik on sellisel juhul juhtiv võõrdetail, mis ulatub ruumiüleselt läbi hoone eri alade.

Alumiiniumist seadmekarbikute korral tagatakse alumiste osade vaheline side ühenduse abil. Ülemiste osade ühendus seadmekarbikuga toimub läbi isekontakteeruva ülaosa. Seeläbi on tagatud püsiv kaitse ilma täiendava juhtme paigaldusvajaduseta.

Metallist LKM-juhtmestikukarbikute korral luuakse ülemise ja alumise osa vaheline ühendus ilma täiendava maandusjuhtmeta. Ühendus alumiste osade vahel toimub vuugiühenduste abil. Tähtis: pulbervärviga kaetud metallist ülaosad ei kuulu segapaigalduse alla ning ei ole seetõttu isoleerivad! Seetõttu tuleb nende puhul rakendada kaitseabinõusid. Terasplekist vaheseinad on isekontakteeruvad. Ka kondensaatorühenduse ning võimaliku staatilise laengu seisukohast vaadatuna tuleb metallist seadmekarbikute ülaosadel ette näha kaitsejuhtme funktsioon. Nende varjestusmeetmete abil väheneb elektrisudu ning saavutatakse parem üldine EMÜ-kaitse. Kaitsejuhtmeühendused peavad olema püsivad. Süsteemi muutmise korral, nt järelpaigalduse korral on oluline tagada kaitsefunktsioonide säilimine.



## Kes milliseid norme järgima peab?

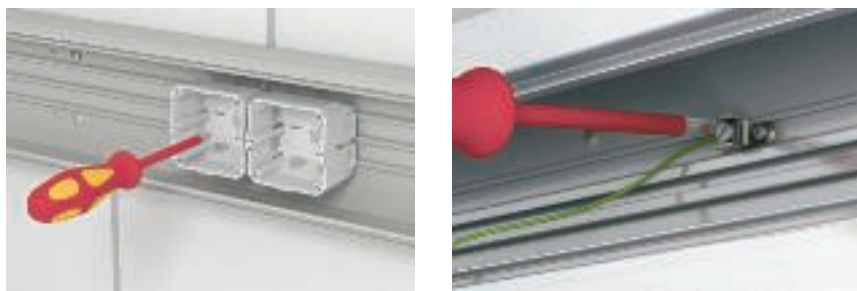

### OBO kui tootja

Norm	Pealkiri	OBO süsteem
DIN EN 50085-1 seadmekontrolli säte	Elektripaigalduskanalisüsteemid elektripaigaldistele, osa 1: üldised nõuded	Kõik süsteemid
DIN EN 50085-2-1	Erinõuded seina ja lae elektripaigalduskarbikusüsteemidele.	WDK, LKM, SKL, GEK-K, GEK-S, GEK-A
prEN 50085-2-2	Erinõuded elektripaigaldussüsteemidele pörandaaluseks, pörandaga tasapinnaliseks või pörandapealseks paigalduseks.	UFS
DIN EN 50085-2-3	Erinõuded elektripaigalduskarbikusüsteemidele lülituskappides.	VK
prEN 50085-2-4	Erinõuded lahtistele paigaldusüksustele.	ISS

### Paigaldaja kui süsteemi looja

Norm	Pealkiri	OBO süsteem
VDE 0100 osa 410	Kuni 1000 V nimipingega elektrisüsteemide loomine. Kaitse elektrilöögi eest.	Kõik süsteemid
VDE 0100 osa 520	Kuni 1000 V nimipingega elektrisüsteemide loomine. Kaablid ja juhtmed.	Kõik süsteemid
VDE 0100 osa 540	Kuni 1000 V nimipingega elektrisüsteemide loomine. Potentsiaaliühtlustus.	Kõik süsteemid
VDE 0100 osa 610	Kuni 1000 V nimipingega elektrisüsteemide loomine. Elektrisüsteemide esmakontroll enne käitajale üleandmist.	Kõik süsteemid
VDE 0298	Kuni 1000 V nimipingega elektrisüsteemide loomine. Tugevvoolusüsteemide iso- leeritud kaablid ja juhtmed.	Kõik süsteemid
DIN EN 50310	Maandus- ja potentsiaaliühtlustusabinõude kasutamine infotehnoloogiaseadmetega hoonetes.	Kõik süsteemid



## Kuidas teha kindlaks kaablimaht

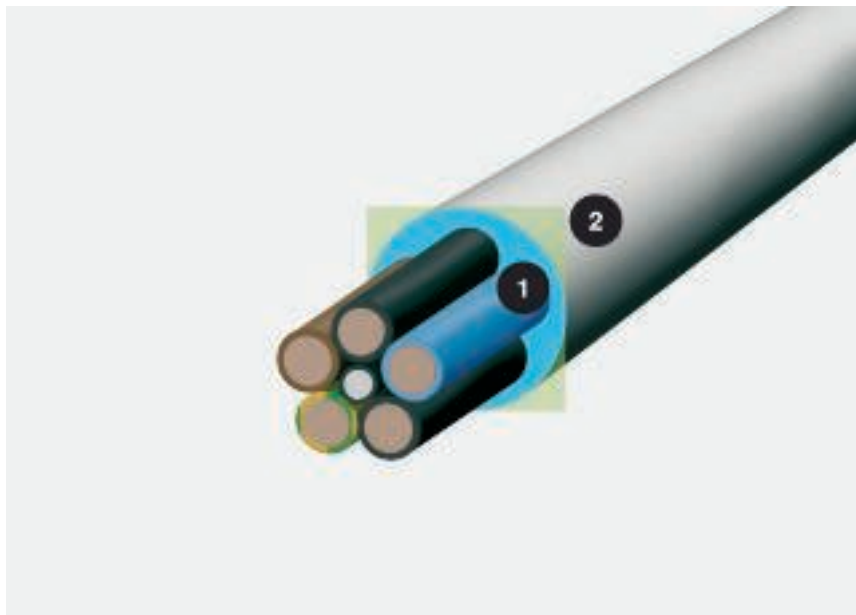

Kaabli läbimõõt ja ruumivajadus; 1 = läbimõõt, mm, 2 = ruumivajadus, cm<sup>2</sup>

Vajaliku karbikusuuruse valimisel on oluline kriteerium kaablimaht. Et kaablid ei paikne kunagi tihedalt üksteise kõrval ja ei ole absoluutselt paralleelsed, ei piisa mahuarvutustes ainult kaabli läbimõõdu arvestamisest. Realistliku aluse mõõtmete määramiseks annab valem  $(2r)^2$ . Töö lihtsustamiseks on käesoleval paarisleheküljel esitatud olulisemate kaablitüüpide läbimõõdud ja ruumivajadus. NB! Väärtused on esitatud keskmistena ja võivad erinevatel tootjatel varieeruda. Täpsed väärtused leiab tootja andmetest.

### Õige valik

Karbiku õige suuruse valimisel aitab teid sellel lehel olev tabel. Lisaks vastava karbiku kasulikule ristlõikele tuleb järgida ka tavapäraseid DIN/DE-norme täiteteguri kohta

### Arvutamine valemi abil $(2r)^2$

Kaabli läbimõõt ütleb selle tegeliku ruumivajaduse kohta vähe. Arvutage valemiga:  $(2r)^2$ . See väärtus iseloomustab reaalselt ruumivajadust, võttes arvesse ka vahe-ruume.



## Üldine planeerimisabi: kaabli mahtude tabel



### Isoleeritud tugevvoolujuhmed

Tüüp	Läbimõõt, mm	Kasuliku ristõike pindala, cm <sup>2</sup>
1 x 4	6,5	0,42
1 x 6	7	0,49
1 x 10	8	0,64
1 x 16	9,5	0,9
1 x 25	12,5	1,56
3 x 1,5	8,5	0,72
3 x 2,5	9,5	0,9
3 x 4	11	1,21
4 x 1,5	9	0,81
4 x 2,5	10,5	1,1
4 x 4	12,5	1,56
4 x 6	13,5	1,82
4 x 10	16,5	2,72
4 x 16	19	3,61
4 x 25	23,5	5,52
4 x 35	26	6,76
5 x 1,5	9,5	0,9
5 x 2,5	11	1,21
5 x 4	13,5	1,82
5 x 6	14,5	2,1
5 x 10	18	3,24
5 x 16	21,5	4,62
5 x 25	26	6,76
7 x 1,5	10,5	1,1
7 x 2,5	13	1,69



### Isoleeritud tugevvoolukaablid

Tüüp	Läbimõõt, mm	Kasuliku ristõike pindala, cm <sup>2</sup>
1 x 10	10,5	1,1
1 x 16	11,5	1,32
1 x 25	12,5	1,56
1 x 35	13,5	1,82
1 x 50	15,5	2,4
1 x 70	16,5	2,72
1 x 95	18,5	3,42
1 x 120	20,5	4,2
1 x 150	22,5	5,06
1 x 185	25	6,25
1 x 240	28	7,84
1 x 300	30	9
3 x 1,5	11,5	1,32
3 x 2,5	12,5	1,56
3 x 10	17,5	3,06
3 x 16	19,5	3,8
3 x 50	26	6,76
3 x 70	30	9
3 x 120	36	12,96
4 x 1,5	12,5	1,56
4 x 2,5	13,5	1,82
4 x 6	16,5	2,72
4 x 10	18,5	3,42
4 x 16	21,5	4,62
4 x 25	25,5	6,5
4 x 35	28	7,84
4 x 50	30	9
4 x 70	34	11,56
4 x 95	39	15,21
4 x 120	42	17,64
4 x 150	47	22
4 x 185	52	27
4 x 240	58	33,6
5 x 1,5	13,5	1,82
5 x 2,5	14,5	2,1
5 x 6	18,5	3,42
5 x 10	20,5	4,2
5 x 16	22,5	5,06
5 x 25	27,5	7,56
5 x 35	34	11,56
5 x 50	40	16



### Ülekandeliinid

Tüüp	Läbimõõt, mm	Kasuliku ristõike pindala, cm <sup>2</sup>
2 x 2 x 0,6	5	0,25
4 x 2 x 0,6	5,5	0,3
6 x 2 x 0,6	6,5	0,42
10 x 2 x 0,6	7,5	0,56
20 x 2 x 0,6	9	0,81
40 x 2 x 0,6	11	1,12
60 x 2 x 0,6	13	1,69
100 x 2 x 0,6	17	2,89
200 x 2 x 0,6	23	5,29
2 x 2 x 0,8	6	0,36
4 x 2 x 0,8	7	0,49
6 x 2 x 0,8	8,5	0,72
10 x 2 x 0,8	9,5	0,9
20 x 2 x 0,8	13	1,69
40 x 2 x 0,8	16,5	2,72
60 x 2 x 0,8	20	4
100 x 2 x 0,8	25,5	6,5
200 x 2 x 0,8	32	10,24



### Andmekaabli tüüp Cat...

Tüüp	Läbimõõt, mm	Kasuliku ristõike pindala, cm <sup>2</sup>
Cat. 5	8	0,64
Cat. 6	8	0,64



### Koaksiaaljuhe (Standard)

Tüüp	Läbimõõt, mm	Kasuliku ristõike pindala, cm <sup>2</sup>
SAT/BK-juhe	6,8	0,48



## Igale materjalile õige tööriist

Eri materjale tuleb erinevalt käidelda. Seadmekarbikute paigaldamisel on osutunud väga kasulikuks eerungisaed. Nendega on võimalik teha täpseid lõikeid.

PVC- ja PC/ABS-karbikud

- Peenhammastusega käsisaag (rauasaag)
- Rauast või plastist saelehega peenhammastusega jõhvsaag
- Kreissaag plastist saelehega, 350 mm läbimõõt, 80-108 hammast/tollil ja 2800 p/min

Terasplekist ja alumiiniumist karbikud:

- Lintsaag kõvale metallile mõeldud saelehega
- Kreissaag kõvale metallile mõeldud saelehega, 350 mm läbimõõt, 80-108 hammast/tollil ja 2800 p/min
- Nurklihvija koos materjalialduslehega

### Arvestage materjalide pikisuunas venimisega

Eri materjalidel on erinev pikisuunaline venimine, millega tuleb arvestada. Alltoodud valemi abil saab välja selgitada PVC, terase ja alumiiniumi paisumise.

$$\Delta L = L \cdot \alpha \cdot \Delta T$$

L = pikkus m

$\alpha$  = soojuspaisumistegur

$\Delta T$  = temperatuurimuutus

Soojuspaisumiskoeffitsient:

- Teras:  $14 \times 10^{-6}/1 \text{ K}$
- Alumiinium:  $23,1 \times 10^{-6}/1 \text{ K}$

- Kõva PVC:  $71 \times 10^{-6}/1 \text{ K}$

### Näited

20° temperatuurierinevuse ( $\Delta t$ ) korral muutub 2000 mm standardpikkus järgmiselt:

- kõva PVC korral 2,84 mm
- terasel 0,56 mm
- alumiiniumil 0,924 mm

### Täiuslik koostoime töö tõhusdamiseks

Kiirem ja parem paigaldus - selle saavutamise nimel töötame samamoodi nagu elektriseadmete tootjad. Nii on varem kasutatud poldipüstolitest saanud kaasaegsed naelaautomaadid. Pulsa 700E näol pakub Spit selles valdkonnas elektritööstuse jaoks mõeldud kõrgeima kvaliteediga seadmeid. Paljusid OBO tooteid saab nende seadmete abil eriti tõhusalt käidelda. Seda tõestavad juhtmestikukarbikute ja seadmekarbikusüsteemide monteerimisel Spiti seadmetega tehtud katsed.

### Kasutatava kõva PVC omadused

Omadus	Väärtus	DIN
Materjalitähis	PVC-U-E-D-08-04-28	vastavalt DIN 7748
Tõmbetugevus	min 40 N/mm <sup>2</sup>	vastavalt standardile DIN 53 455
Katkevenivus	min 85 %	vastavalt standardile DIN 53 455
Läbilöögikindlus	min 20 KV/mm	vastavalt standardile DIN 53 481
Pinnatakistus	min 1010 oomi	vastavalt standardile DIN 53 455
Vormikindlus soojas	min 75 °C	vastavalt standardile DIN 53 400/B
Temperatuurikindlus rakenduses	max 65 °C	
Süttivus	Aste V-0	vastavalt standardile UL 94
Hõõgniidi kontroll	960 °C	vastavalt standardile DIN IEC 695

Üksikasjalikud andmed leiate peatükist "Kõva PVC kemikaalikiindlus" jaotisest "Lisateave".

## Värvid



### **RAL, NCS, DB**

Standardvärvid ja paljude erivärvid lai valik võimaldab integreerida juhtmestikussüsteeme mis tahes büroo värvilahendusega. Plastist juhtmestiku- ja seadmekarbikusüsteemide standardvariandid on saadaval RAL-värvadena polaarvalge (RAL 9010), helehall (RAL 7035), kivihall (RAL 7030) ja kreemvalge (RAL 9001). Terasplekist ja alumiiniumist seadmekarbikusüsteemide ja karbikpostide puhul on saadaval standardvärvid polaarvalge, helehall ja kreemvalge. Pulbervärvi korral on terasplekist ja alumiiniumist lahenduste korral võimalikud ka kõik muud RAL-värvid. Erinevalt RAL-i standardist saab soovi korral kasutada ka NCS- ja DB-värve.





## VK traadistuskarbikusüsteemid



VK traadistuskarbikusüsteemi omadused, Dahli süsteem	28
VK traadistuskarbiku täitekogused	29
Perforatsioonimustrid ja mõõtmed	30
VK traadistuskarbiku paigaldusabi	32



## Omadused: VK traadistuskarbikusüsteem, süsteem Dahl

Traadistuskarbiku planeerimisabi

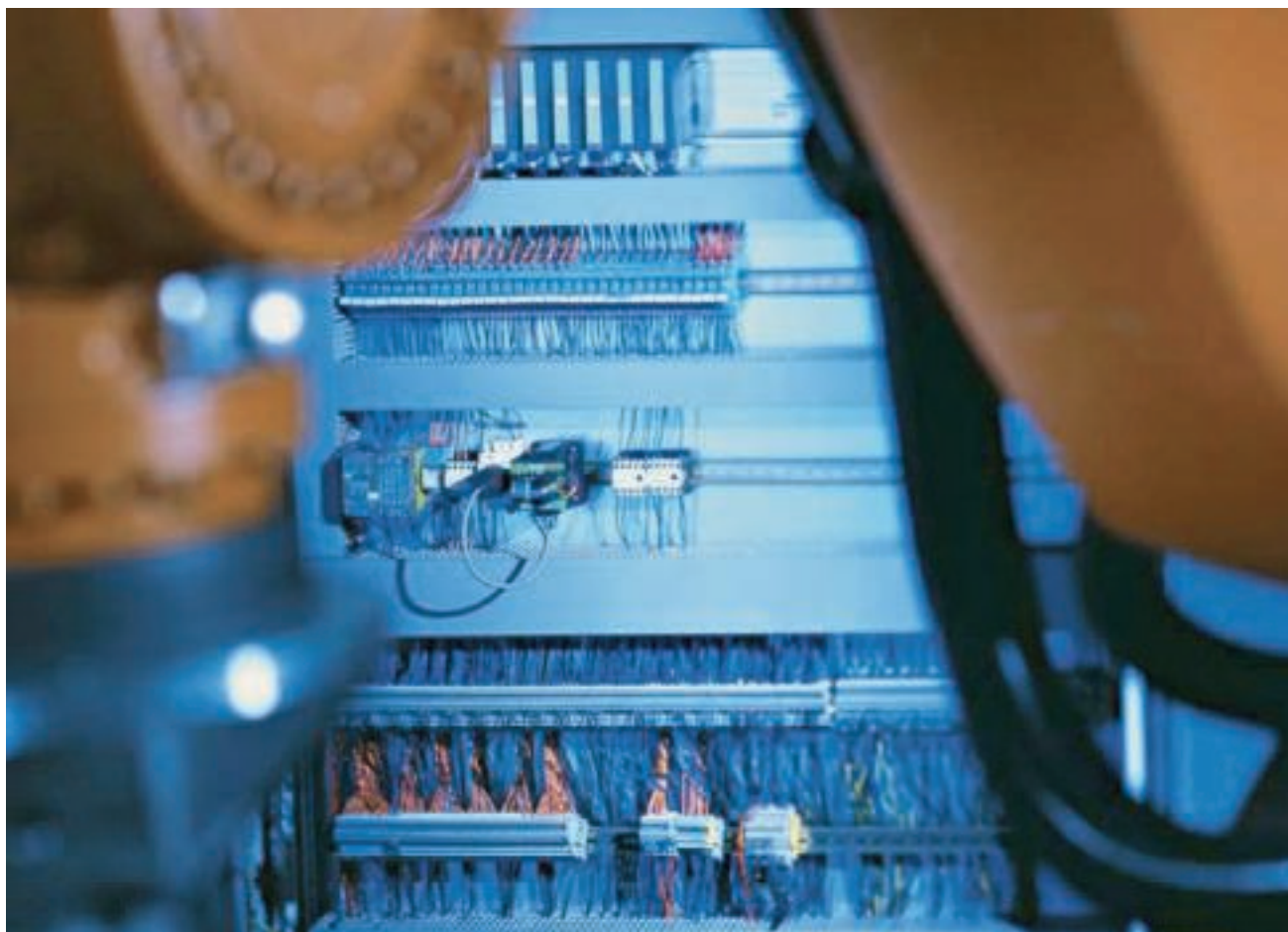

### VK traadistuskarbikute eelised

VK traadistuskarbikusüsteem Dahl on hea kvaliteedi ning sametpehmete, kidadeta piludega. Ümaraks lihvitud juhikud takistavad vigastuste tekkimist paigaldamisel.

Täiendavad eelised on:

- stabiilsed, suure seinapakusega karbikud
- täpsed murdekohad astmete korral ja põrandal
- küljeperforatsiooni absoluutselt täpsed mõõtmed
- põrandaperforatsiooni absoluutselt täpsed mõõtmed
- põrandaperforatsiooni algusmõõtu saab kliendi soovil muuta
- lukkude lõikeservad on ümaratud kidavabalt.
- VDE poolt kontrollitud
- UL-kontrollitud ja registreeritud, UL-toimiku nr E301798
- erimudelid nõudmisel
- kaante kindel paigaldus tänu optimaalsetele lukustuskontuuridele



## VK traadistuskarbiku täitekogused

### Sobiva karbikusuuruse väljaselgitamine

Juhtmete arv, juhtmetüübid ja ristlõiked on karbiku õige suuruse valimisel otsustavad. Selleks, et teie valikut lihtsustada, oleme alljärgnevas tabelites loetlenud VK-karbikute maksimaalsed täitekogused levinumate kaablitüüpidega.

Tähtis:

Tabelis on toodud teoreetiliselt arvutatud väärtused! Tabelites pole arvestatud järgmiste teguritega:

- juhtmete sisendid ja väljundid
- viltu paigaldatud juhtmed
- juhtmete akumuleerumine, kontsentratsioon ristumispunktid

- lülituskapis eeldatavalt tekivad temperatuurid Nõuetekohase paigalduse eest vastutab paigaldaja. Soovitame planeerimisel arvestada maksimaalse täiteteguriga 50%.

### VK karbiku max täitekogus (100%) sõltuvalt kaabli tüübist

VK-karbik, Tüüp LK4 - LK4/N	Kaablitüüp 0,75 mm <sup>2</sup> , d = 2,8 mm	Kaablitüüp 1,00 mm <sup>2</sup> , d = 2,9 mm	Kaablitüüp 1,5 mm <sup>2</sup> , d = 3,2 mm
15015	17	16	14
30015	36	34	28
30025	58	54	45
40025	80	74	61
40040	126	118	97
40060	194	181	149
40080	261	244	200
40100	329	307	252
60015	75	70	57
60025	122	113	93
60040	195	182	150
60060	296	276	227
60080	397	370	304
60100	499	466	382
60120	600	560	460
80025	164	153	126
80040	263	245	202
80060	398	371	305
80080	533	497	408
80100	669	624	512
80120	804	750	616

### VK karbiku max täitekogus (100%) sõltuvalt kaabli tüübist

VK-karbik, Tüüp LKV - LKV/N	Kaablitüüp 0,75 mm <sup>2</sup> , d = 2,8 mm	Kaablitüüp 1,00 mm <sup>2</sup> , d = 2,9 mm	Kaablitüüp 1,5 mm <sup>2</sup> , d = 3,2 mm
25025	36	34	28
37025	58	54	45
37037	94	88	72
50025	80	75	61
50037	129	120	99
50050	178	166	136
50075	273	255	209
75025	123	114	94
75037	192	179	147
75050	267	249	204
75075	417	388	318
75100	560	522	428
75125	596	556	456
10037	258	240	198
10050	356	332	272
10075	560	522	428
100100	712	664	544



## Perforatsioonimustrid ja mõõtmed

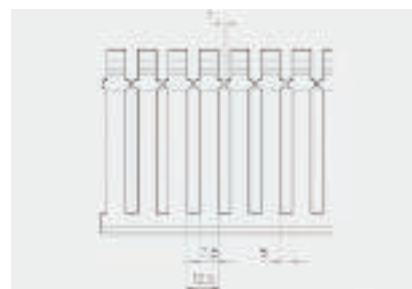
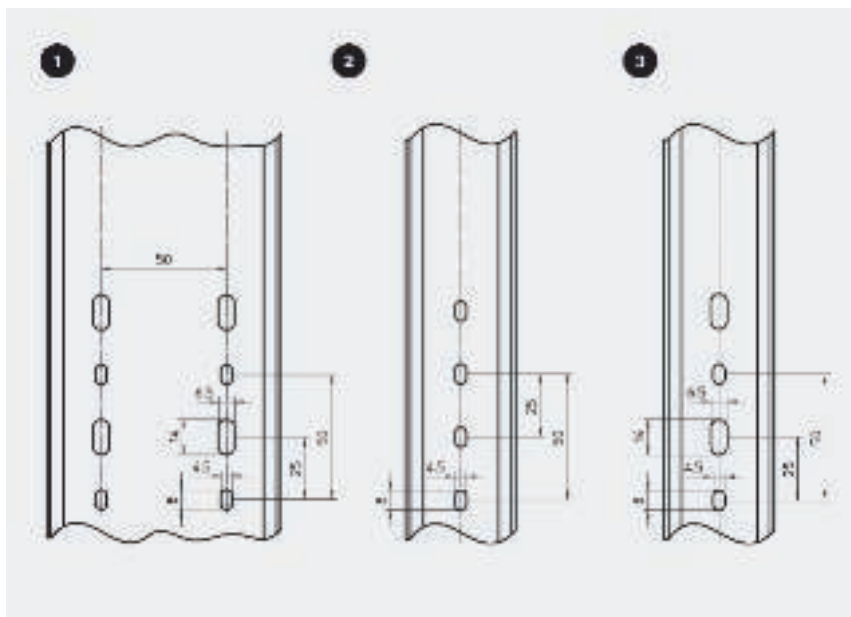

LKV

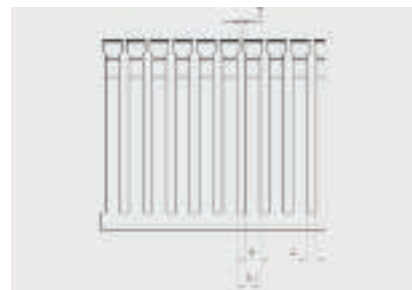

LK4

LK4/LK4/N	Toote nr	Perforatsioon
LK4 15015	6178001	2
LK4 30015	6178003	2
LK4 30025	6178005	3
LK4 40025	6178010	3
LK4 40040	6178012	3
LK4 40060	6178014	3
LK4 40080	6178016	1
LK4 40100	6178018	1
LK4 60015	6178026	2
LK4/N 60015	6178201	2
LK4 60025	6178028	3
LK4/N 60025	6178203	3
LK4 60040	6178031	3
LK4/N 60040	6178205	3
LK4 60060	6178033	3
LK4/N 60060	6178207	3
LK4 60080	6178035	1
LK4/N 60080	6178209	1
LK4 60100	6178037	1
LK4/N 60100	6178211	1
LK4 60120	6178039	1
LK4/N 60120	6178213	1

LK4/LK4/N	Toote nr	Perforatsioon
LK4 80025	6178050	3
LK4/N 80025	6178225	3
LK4 80040	6178052	3
LK4/N 80040	6178227	3
LK4 80060	6178054	3
LK4/N 80060	6178229	3
LK4 80080	6178056	1
LK4/N 80080	6178231	1
LK4 80100	6178059	1
LK4/N 80100	6178233	1
LK4/N 80120	6178236	1
LK4/N 80120	6178236	1
LK4/N 80120	6178236	1

## Perforatsioonimustrid ja mõõtmed

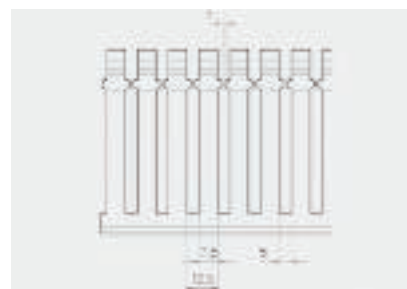
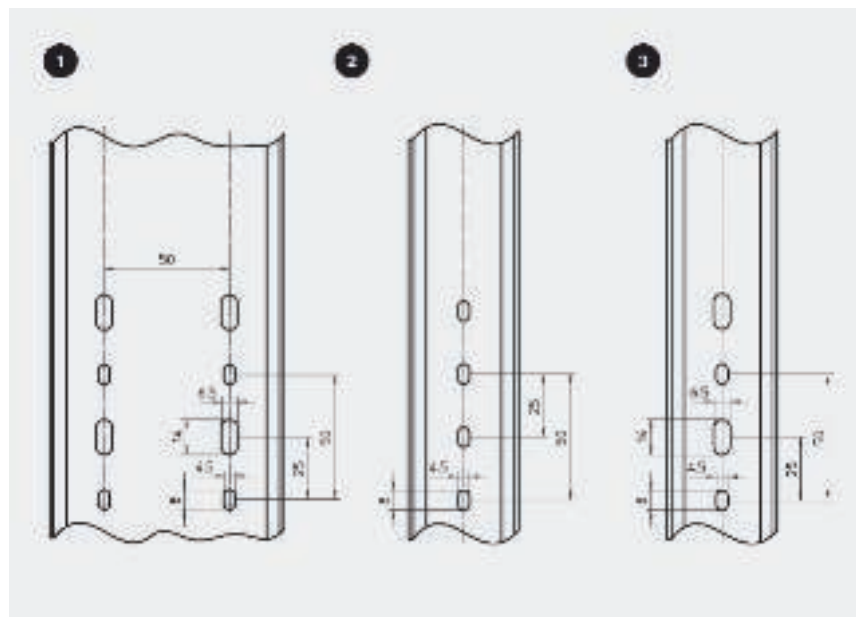

LKV

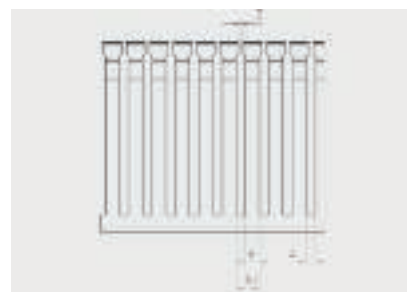

LK4

Traadistuskarbiku planeerimisabi



LKV/LKV/N	Toote nr	Perforatsioon
LKV 25025	6178302	3
LKV 37025	6178305	3
LKV 37037	6178307	3
LKV 50025	6178310	3
LKV 50037	6178312	3
LKV 50050	6178314	3
LKV 50075	6178316	1

LKV/LKV/N	Toote nr	Perforatsioon
LKV 75025	6178320	3
LKV/N 75025	6178420	3
LKV 75037	6178322	3
LKV 75037	6178422	3
LKV 75050	6178324	3
LKV/N 75050	6178424	3
LKV 75075	6178326	1
LKV/N 75075	6178426	1
LKV 75100	6178328	1
LKV/N 75100	6178428	1
LKV 75125	6178330	1
LKV/N 75125	6178430	1
LKV 10037	6178334	3
LKV/N 10037	6178435	3
LKV 10050	6178336	3
LKV/N 10050	6178437	3
LKV 10075	6178338	1
LKV/N 10075	6178439	1
LKV 100100	6178341	1

LKV/H	Toote nr	perforatsioon
LKV/H 50037	6178612	2
LKV/H 50050	6178614	2
LKV/H 50075	6178616	2
LKV/H 75037	6178622	2
LKV/H 75050	6178624	2
LKV/H 75075	6178626	1
LKV/H 75100	6178628	1
LKV/H 75125	6178630	1

# VK traadistuskarbiku paigaldusabi



## Kasutusala: lülituskapp

VK traadistuskarbikuga on nüüd tagatud kaablite puhtalt vedamine lülituskapis.



## Traadistuskarbiku montaaž

VK traadistuskarbik kinnitatakse ankurneetide abil lülituskapi montaažiplaadile. Ankurneedid monteeritakse plastneedipaigaldajaga.



## Nagade väljamurdmine

Nagad painutatakse väljapoole. Kui paindenurk ületab umbes 70° - 80°, siis nagad murduvad.



## Lõiketangid

Väljavajutustangide abil saate murda külgmised nagad välja kuni karbiku pörandani. Pärast küljeseinte väljamurdist ei teki üleminekuualades ühendatava karbikuga mahukadusid.

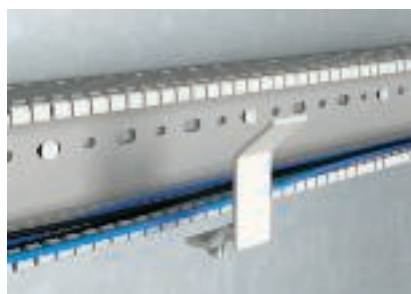

## Traadihoidikud

Traadihoidikuid saab kohandada vastavalt karbiku laiuusele. Selleks lahutatakse traadihoidik ettenähtud murdekohtadest. Seega on kõigi karbikulaiuste jaoks vajalik ainult üks traadihoidik.

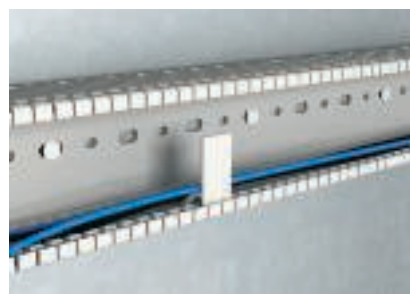

## Traadihoidiku montaaž

Traadihoidik viiakse VK traadistuskarbiku külgmisse lõhesse. See lihtsustab kaablite paigaldamist ja hoiab need VK traadistuskarbikus paigal. Nii tagatakse kaane lihtne pealepanek. Võimaliku järelpaigalduse korral hoitakse kaableid karbiku kaane eemaldamisel karbikus ning need ei kuku välja.



## Traadikinnitusnagad

N-versioonidel on küljesilluses kinnituseend, mis võimaldab kaabli VK traadistuskarbikusse kinnitada.



## Kaane kontuur LK4

Väga täpne töötlus võimaldab vaatamata kaane kindlale istule pealmise osa hõlpsamat pealepanemist ja äravõtmist.



## Kaane kontuur LKV

Tänu kaane spetsiaalsele kontuurile on ka LKV traadistuskarbiku korral tagatud ideaalne istuvus.



## Distantsoidiku montaaž

Distantsoidikuga saab VK traadistuskarbiku monteerida montaažiplaadist kõrgemale.

## VK traadistuskarbiku paigaldusabi

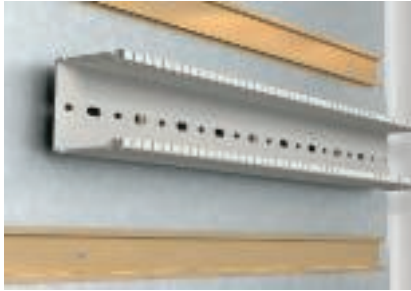

### **Distantsoidiku montaaž**

Distantsoidikuid saab paigaldada üksteise peale, et luua suuremaid kaugusi paigaldusplaadist. Nii saavutatakse teatav paindlikkus VK traadistuskarbiku taha paigaldatavate kaablite kõrguse osas.



### **Põhjaperforeering**

Ühe- ja kahesooneelised põrandaavad vastavalt standardile DIN 43659 võimaldavad täpset töötamist.



### **Valmismontaaž**

Tänu paljudele praktilistele suurustele ja tarvikutele saab lülituskapis teostada professionaalse paigalduse.



# Plastmaterjalid

## ABS/ASA — akrüülnitriilbutadienstüreen

Temperatuurikindlus: pidevalt kuni 70 °C, lühiajaliselt kuni 85 °C ning kuni umbes -40 °C\*.

### Vastupidav järgmisele:

Sipelghape, sidrunhape, piimhape.

### Tingimuslikult vastupidav järgmisele

Soolhape, väävelhape.

### Ei talu:

Atsetoon, bensiin, bensool, lahustid värvide ja lakkide jaoks, võihape, kloor, äädikhape, lämmastikhape.

### Pingepragunemise oht

Suhteliselt kõrge, samane polüstüreenile.

## GUM — kummi

## HP — Tugev papp

## MGUM — Vahtkummi

## POM — Polüatsetaal

Temperatuurikindlus: pidevalt kuni 100 °C, lühiajaliselt kuni 130 °C ning kuni umbes -40 °C.

### Vastupidav järgmisele:

Atsetoon, eeter, bensiin, nõrgad äädikhapped, bensool, kütteõli, õlid ja rasvad, toluen.

### Ei talu:

Metüleenkloriid, triklooretüleen, soolhape, lämmastikhape, väävelhape.

### Pingepragunemise oht

Väike

## PA — polüamiid

Temperatuurikindlus: pidevalt kuni ca 90 °C, lühiajaliselt kuni ca 130 °C ning kuni umbes -40 °C\*. Keemiline vastupidavus üldiselt nagu polüetüleenil.

### Vastupidav järgmisele:

Bensiin, bensool, diisliõli, atsetoon, lahustid värvide ja lakkide ning õlide ja rasvade jaoks.

### Ei talu:

Pleegitusleelilahus, enamik happeid, kloor.

### Pingepragunemise oht

Õhuniiskes seisundis väike, vaid mõnede lahjade soolalahuste puhul. Tugevasti ära kuivanud osade puhul (kõrge temperatuur ja väga väike õhuniiskus) väga vastuvõtlik kütuste ja erinevate lahustite suhtes.

## PA/GF — polüamiid, klaaskiudtugevdatud

Temperatuurikindlus: pidevalt umbes 100–110 °C, lühiajaliselt kuni 160 °C ning kuni umbes -40 °C\*.

### Vastupidav järgmisele:

Bensiin, bensool, diisliõli, atsetoon, lahustid värvide ja lakkide ning õlide ja rasvade jaoks. Vähene vastuvõtlikkus pingepragunemisele.

### Ei talu:

Pleegitusleelilahus, enamik happeid, kloor.

### Pingepragunemise oht

Õhuniiskes seisundis väike, vaid mõnede lahjade soolalahuste puhul. Tugevasti ära kuivanud osade puhul (kõrge temperatuur ja väga väike õhuniiskus) väga vastuvõtlik kütuste ja erinevate lahustite suhtes.

## PC — polükarbonaat

Temperatuurikindlus: pidevalt kuni ca 110 °C (vees 60 °C), lühiajaliselt kuni ca 125 °C ning kuni umbes -35 °C.

### Vastupidav järgmisele:

Bensiin, tärpentin, enamik nõrku happeid.

### Ei talu:

Atsetoon, bensool, kloor, metüleenkloriid, enamik kontsenteeritud happeid.

### Pingepragunemise oht

Suhteliselt väike, pingepragunemist põhjustavad keskkonnad on muuhulgas bensiin, aromaatsed süsivesinikud, metanool, butanool, atsetoon, tärpentin.

## PC/ABS — Polykarbonaat/akrüülnitriil-butadien-stüreen

## PE — Polüetüleen

Temperatuurikindlus: tugevad sordid püsivad kuni 90 °C, lühiajaliselt kuni 105 °C, nõrgemad sordid püsivad kuni 80 °C, lühiajaliselt kuni 100 °C ning umbes -40 °C.

### Vastupidav järgmisele:

Leeliselahused ja anorgaanilised happed.

### Tingimuslikult vastupidav järgmisele

Atsetoon, orgaanilised happed, bensiin, bensool, diisliõli, enamik õlisid.

### Ei talu:

Kloor, süsivesinikud, oksüdeeruvad happed.

### Pingepragunemise oht

Suhteliselt kõrge. Pingepragunemist võivad muuhulgas põhjustada atsetoon, erinevad alkoholid, sipelghape, etanool, bensiin, bensool, võihape, äädikhape, formaldehüüd, erinevad õlid, petrooleum, propanool, lämmastikhape, soolhape, väävelhape, seebilahused, tärpentin, triklooretüleen, sidrunhape.

## PP — polüpropüleen

Temperatuurikindlus: pidevalt kuni ca 90 °C, lühiajaliselt kuni ca 110 °C ning kuni umbes -30 °C\*. Keemiline vastupidavus üldiselt nagu polüetüleenil.

### Vastupidav järgmisele:

Leeliselahused ja anorgaanilised happed

### Tingimuslikult vastupidav järgmisele

Atsetoon, orgaanilised happed, bensiin, bensool, diisliõli, enamik õlisid

### Ei talu:

Kloor, süsivesinikud, oksüdeeruvad happed

### Pingepragunemise oht

Väike, vaid mõnede hapete nagu kroomhape, fluorhape ja soolhape ning lämmastikoksiidi korral.

## PVC — Polüvinüülkloriid

Temperatuurikindlus: pidevalt umbes 65 °C, lühiajaliselt kuni 75 °C ning kuni umbes -30 °C\*.

### Vastupidav järgmisele:

Nõrgad happed, leeliselahused, õlid ja rasvad, bensiin.

### Ei talu:

Tugevad happed, bensool, atsetoon, jood, toluen, triklooretüleen.

### Pingepragunemise oht

Vähene, vaid mõnede lahustitega nagu bensool ja atsetoon.

## PPO — polüfenüleenoksiid

Temperatuurikindlus -30 kuni +85 °C

### Ei talu:

Õli, rasva, määrdeained ja mootorikütused



# Euroopa klassifikatsioon

## Klassifikatsioon vastavalt standardile EN 50085-1

		WDK juhtmestikukarbik	LKM juhtmestikukarbik	SKL- põrandaliistikarbik	VK traadistuskarbik	GEK-A seadmekarbik Rapid 45	GEK-A seadmekarbik Rapid 45	GK seadmekarbik	GK seadmekarbik	GEK-A seadmekarbik	ISS karbikpost
6,1	Toimeaine järgi	*2	*2	*2	*2	*2	*2	*2	*2	*2	*2
6,2	Paigalduse ja kasutamise löögikindluse järgi		*1								
6.2.1	Elektripaigalduskanalisüsteemid löögienergiale 0,5 J	x	*1								
6.2.2	Elektripaigalduskanalisüsteemid löögienergiale 1 J		*1								
6.2.3	Elektripaigalduskanalisüsteemid löögienergiale 2 J		*1								
6.2.4	Elektripaigalduskanalisüsteemid löögienergiale 5 J		*1			x		x			
6.2.5	Elektripaigalduskanalisüsteemid löögienergiale 20 J		*1				x		x	x	x
6,3	Temperatuuri järgi, vastavalt tabelites 1, 2 ja 3 esitatud andmetele										
	Tabel 1: Minimaalsed ladustamis- ja transporditemperatuurid ± 2 °C										
	-45										
	-25		x				x		x	x	x
	-15		x			x		x			
	-5	x	x		x						
	Tabel 2: Minimaalsed paigaldus- ja kasutustemperatuurid ± 2 °C										
	-25		x				x		x	x	x
	-15					x		x			
	-5	x									
	+5										
	+15				x						
	Tabel 3: Maksimaalsed kasutustemperatuurid ± 2 °C										
	+60	x			x	x	x	x	x	x	x
	+90										
	+105										
	+120										
6,4	Tuleleviku tõkestamise järgi										
6.4.1	Tuld edasikandvad elektripaigalduskanalite süsteemid	x			x	x		x			
6.4.2	Tuld mitteedasikandev elektripaigalduskanalite süsteem.		x	x			x		x	x	x

x kehtiv klassifikatsioon, \*1 kontrollimisel, \*2 nõustamisel



# Euroopa klassifikatsioon

## Klassifikatsioon vastavalt standardile EN 50085-1

		WDK juhtmestikukarbik	LKM juhtmestikukarbik	SKL- põrandaliistikarbik	VK traadistuskarbik	GEK-A seadmekarbik Rapid 45	GEK-A seadmekarbik Rapid 45	GK seadmekarbik	GK seadmekarbik	GEK-A seadmekarbik	ISS karbikpost
6,5	Elektrijuhtivuse järgi										
6.5.1	Elektrijuhtimisomadusega elektripaigalduskanalisüsteem		x				x		x	x	x
6.5.2	Ilma elektrijuhtivusomaduseta elektripaigalduskanalisüsteem	x		x	x	x		x			
6,6	Elektriisolatsiooniomaduste järgi										
6.6.1	Ilma elektriisolatsiooniomaduseta elektripaigalduskanalisüsteem	x		x	x	x		x			
6.6.2	Elektriisolatsiooniomadusega elektripaigalduskanalisüsteem		x				x		x	x	x
6,7	Korpuse või kesta poolt tagatava, standardi EN 60529:1991 kohase kaitseklassi järgi										
6.7.1	Tahkete võõrkehade sissetungimise vastase kaitse järgi	x	IP30	x			x	x	x	IP30	IP30
6.7.2	Vee sissetungimise kaitsemeetmete järgi										
6.7.3	Ohtlike osade puudutamise vastase kaitse järgi										
6,8	Vastavalt korrosiivsete ja määrivate ainete vastasele kaitsele	*2									
6,9	Vastavalt karbikukaane kinnitusviisile										
6.9.1	Avage elektripaigalduskanalisüsteemi karbikukaas ilma tööriistata	x	x		x						
6.9.2	Avage elektripaigalduskanalisüsteemi karbikukaas ainult tööriista abil					x	x	x	x	x	
6,10	Vastavalt elektrilisele kaitsele										
6.10.1	Elektripaigalduskanalisüsteemid ilma sisemise vaheseinaelemendita		x		x		x		x	x	
6.10.2	Elektripaigalduskanalisüsteemid koos sisemise vaheseinaelemendiga	x				x		x			

x kehtiv klassifikatsioon, \*2 nõustamisel



# Euroopa klassifikatsioon

## Klassifikatsioon vastavalt EN 50085-2-1

		WDK juhtmestikukarbik	LKM juhtmestikukarbik	SKL- põrandaliistikarbik	VK traadistuskarbik	GEK-A seadmekarbik Rapid 45	GEK-A seadmekarbik Rapid 45	GK seadmekarbik	GK seadmekarbik	GEK-A seadmekarbik	ISS karbikpost
6.101.3	Pinnasisene/-pealne elektripaigalduskanal seinal või laes										
6.101.3.1	Pinnasisene/-pealne elektripaigalduskanal seinal.	x	x			x	x	x	x	x	
6.101.3.2	Pinnasisene/-pealne elektripaigalduskanal laes.	x	x			x	x	x	x	x	
6.101.3.3	Elektripaigalduskanal seinal ja toestatuna põrandal.										
6.101.3.4	Elektripaigalduskanal seinal ja toestatuna teise horisontaalse pinnaga põrandal.										
6.101.4	Elektripaigalduskanalisüsteem, monteerituna kinnitustetailide abil seinast või laest eemale.					x	x	x	x	x	
6 102	Vastavalt vedelike ja isoleeritud redelite ning juhtivate osade vahelise kontakti vastasele kaitsele sokkeliistikarbikute ja põranda märgpuhastuse korral.										
6.102.1	Andmed puuduvad										
6.102.2	Paigaldada täielikult tootja juhendi järgi, milles piiratakse elektripaigalduskarbikusüsteemi paigalduskohta.					x	x				
6.102.3	Paigaldada täielikult tootja juhendi järgi, milles lubatakse elektripaigalduskarbikusüsteemide kõiki paigaldusi, kuid piirab elektripaigalduskarbikusüsteemis isoleeritud juhtmete ja juhtivate osade kihte.										
6.102.4	Paigaldada täielikult tootja juhendi järgi, milles lubatakse elektripaigalduskarbikusüsteemide kõiki paigaldusi, kuid lubab isoleeritud juhtmete ja juhtivate osade kihte.										
6 103	Vastavalt tüübile										
6.103.1	Tüüp 1: elektripaigalduskanalisüsteem										
6.103.2	Tüüp 2: elektripaigalduskanalisüsteem (jaotus-elektripaigalduskanalisüsteem)	x	x								
6.103.3	Tüüp 3: elektripaigalduskanalisüsteem (paigaldus-elektripaigalduskanalisüsteem)				x	x	x	x	x	x	

x kehtiv klassifikatsioon



# Kõva PVC kemikaalikindlus

A = talub väga hästi  
B = keskmine vastupidavus  
C = ei talu

Medium	Temp. °C	VASTUPIDAVUS
1,3-bensooldisulfoonhape	20	A
1,3-butadieen	20	A
2,4-kloorbensoüülkloriid	20	A
2-amino-2,2-difenüüläädikhape	20	A
4-kloor-2-nitraniliin	20	C
4-kloorbensaldehüüd-2-sulfoonhape	20	A
5-amino-2-hüdroksübensoehape	20	A
äädikhape 10%	60	A
äädikhape 100%	20	A
äädikhape 100%	60	B
äädikhape 25%	40	A
äädikhape 25-70%	40	A
äädikhappeanhüdriid	20	C
abietihape	20	A
adipiinhape	20	A
adipiinhape	60	B
aktivaator	40	A
alitsanin 100%	20	A
alkaansulfoonhapped	50	A
alkohoolsed joogid	< 40	A
allüülalkohol 100%	20	B
allüülalkohol 100%	60	C
allüülkloriid	20	C
aminobensool (p-)	20	A
aminobensoolsulfoonhape (m-, o-, p-)	20	A
aminosalitsüülhape (p-)	20	A
ammoniaak (kõigi kontsentratsioonide aur)	40	A
ammoniaak (kõigi kontsentratsioonide aur)	60	B
ammoniaak, veevaba, vedel	< 60	B
ammooniumhüdroksiid	60	A
aniliin 100%	20	A
aniliinkloriid, küllastunud lahus	20	C
askorbiinhape	20	A
asparagiinhape	20	A
atsetaadid (ammoonium-, Na- jt)	50	A
atsetaldehüüd 100%	20	C
atsetaldehüüd 40%	20	A
atsetaldehüüd 40%	40	B
atsetaldehüüd, äädikhappe sisaldus 90:10	20	B
atsetaniliid 100%	20	A
atsetofenoon (metüülfenüülketoon)	20	C
atsetoon	20	C
atsetüleen 100%	20	B
atsetülatsetoon (2,4-pentadioon)	20	C
atsetülsalitsüülhape	20	A
bensiin, aromaativaba	60	A
bensiin, bensoolisaldusega	20	C
bensoefenoon 100%	20	C
bensoehape	40	A
bensoehappeanhüdriid	30	A
bensool	20	C
bensoolsulfoonhape	60	A
bensotrifluoriid	20	C
bensotrikloriid	20	C
bensoüülbensoehape	20	A
bensüülkloriid	20	C
beteen	20	A
booraks	40	A
boorfluorvesinikhape	20	A
boorhape	20	A
boraadid	20	A
bromaadid (K-, Na-)	40	A
bromiidid (K-, Na- jt)	60	A
bromoform 100%	20	C
broom, gaasiline, kuiv	20	A
broom, vedel	20	C
broombensool	20	C
broomhape	20	A
broomkloormetaan	20	C
broomkloorpropan	20	C
broomvesi	20	A
broomvesinik 100%	20	A
broomvesinik 100%	60	B
broomvesinikhape kuni 40%	60	A
butaan, gaasiline, 30%	20	A
butaandioolid kuni 10%	20	A
butaandioolid üle 60%	40	B
butaandioolid üle 60%	20	C
butanool	60	A
butüülatsetaat	20	C
butüülbutüraat	20	C
butüülfenoolid	20	C
butüülgükolaat	20	C
butüülkloriid	20	C
dibroometüleen	20	C
dibütüloksalaat	20	C

A = talub väga hästi  
B = keskmine vastupidavus  
C = ei talu

Medium	Temp. °C	VASTUPIDAVUS
dibütüülfalaat	20	C
dietüleen	60	C
dietüülamiin 100%	20	C
dietüüleeter	20	C
difenüül	20	C
difenüülamiin	20	C
diklooretüleen	20	C
dikloorpropüleen	20	C
dikromaadid (K-, Na-)	50	C
dimetüüleeter	20	C
di-n-butüüleeter	20	C
dioksaan	20	C
dioüülfalaat	20	C
etaan	20	A
etanool	40	A
etanoolamiin	20	B
etüleen	20	A
etüülakrülaad	20	C
etüülatsetaat	20	C
etüülbensool	20	C
etüülkloriid	20	C
fenool 1%	20	A
fenool 90%	45	B
fenüülhüdratsiin	20	C
fenüülhüdratsiinkloriid	20	B
fenüülhüdratsiinkloriid	60	C
fluor	20	B
fluor	60	C
fluoriidid (ammoonium-, K-, Na- jt)	60	A
formaldehüüd	60	A
formamiid 100%	20	C
formiaadid (ammoonium- jt)	20	A
fosfaadid (ammoonium-, Na- jt)	60	A
fosforhape	40	A
fosforhape	60	B
fosforpentoksiid	20	A
fosgeen, gaasiline	20	A
fosgeen, gaasiline	60	B
fosgeen, vedel	20	C
furfurool	20	C
furfurüülalkohol	20	C
glükool	60	A
glükoonhape	20	A
glükoo	60	A
glutamiinhape	20	A
glütseriin	60	A
glütüsiin	40	A
hapnik	60	A
heksafluorüränihape 32%	60	A
heksafluorsilikaadid (ammoonium-, K- jt)	60	A
heksaklooretaan	20	C
heksametüülenetetraamiin (urotopiin) 40% vesilahus	60	A
heksatsüanoferraadid-II (Na-)	40	A
heksatsüanoferraadid-III (K-)	40	A
heptaan	20	A
hüdratsiini lahendatud lahus 100%	20	C
hüdratsiini lahendatud lahus 30%	20	A
hüdroksiidid (K-, Na-)	60	A
hüdroksiidid (eeliselised muldmetal-)	60	A
humihapped	20	A
hüpokloorhape	60	A
hüpokloriidid (K-, Na- jt)	60	A
isobütüülfosfaat	20	C
jodaadid (K-, Na- jt)	60	A
jodiidid (K-, Na-)	60	A
jood	20	C
kinnisti	60	A
kloor, gaasiline, kuiv 0,5%	20	A
kloor, gaasiline, kuiv 100%	20	B
kloor, gaasiline, niiske 5%	20	B
kloor, vedel	20	C
klooräädikhape	20	A
klooraniliin	20	C
klooratseetaldehüüd	20	C
klooratsetoon	20	C
klooratsetüülkloriid	20	C
kloorbensaldehüüd	20	C
kloorbensool	20	C
kloorbensotrifluoriid	20	C
kloorbensoüülkloriid	20	C
kloorretüülbensool	20	C
kloorhape kuni 20%	40	A
kloorhape kuni 20%	60	B
kloorivesi (küllastunud lahus)	20	B
kloorkresoolid	20	C
kloornaftaliin	20	C



# Kõva PVC kemikaalikindlus

A = talub väga hästi  
B = keskmine vastupidavus  
C = ei talu

Medium	Temp. °C	VASTUPIDAV US
Kloornitrobensoehape	20	A
Kloorstüaan	20	A
Kloorvesinik (gaasiline, kuiv ja niiske)	40	A
kloraat (K-, Na- jt)	20	A
kloraat (K-, Na- jt)	60	B
kloraat (K-, Na- jt)	60	A
kloriidid (ammoonium-, Na- jt)	20	A
kloroform	20	C
kresool	20	C
kromaadid (K-, Na- kuni 50%)	50	A
kroomalauun	60	A
kroomhape kuni 50%	40	A
kroomvävelhape	30	A
ksüloolid	20	C
kumool	20	C
kusiaine	60	C
lakk	60	C
lämmastikoksiidid	20	C
lämmastikushape kuni 50%	50	A
lämmastikushape kuni 98%	20	C
Linaseemneõli	60	A
linohape	60	A
Materjali omadused		
metanool 100%	40	A
metanool 100%	60	B
metüleenkloriid	20	C
metüülamiin	20	B
metüülbromiid	20	C
metüülkloriid	20	C
metüülmetakrülaad	20	C
mineraalõlid	60	C
N, N-dietüülalaniin	20	C
naftaliin	20	C
nitrobensool	20	C
nitraadid (ammoonium-, K- jt)	60	A
nitriidid (K-, Na- jt)	60	A
nitroglütseriin	20	B
okalaadid (ammoonium-, Na- jt)	60	A
oksaalhape	40	A
õlihape	60	A
õllevärtsid	20	A
õlu	60	A
osoon 10%	30	A
osoon 10%	60	B
õunamahl	60	A
õunhape	20	A
paksus	60	A
palmiitinhape	20	A
parafiin	40	A
parkaine	20	A
pentüülalkohol	60	A
pentüülatsetaat	20	C
pentüülkloriid	20	C
pentüüllauraad	20	C
perbonaat (K-)	60	A
perkloorhape 70%	20	A
perkloraat	40	A
permanganaat (K-) 6 kuni 15%	40	A
permanganaat (K-) 6 kuni 15%	60	B
permanganaat (K-) 6%	60	A
peroksümonoväävelhape	20	A
persulfaad (ammoonium-, K- jt)	40	A
petrooleum	60	A
piim	20	A
piimhape 10%	20	A
piimhape 10%	60	C
piimhape 100%	20	C
pleegituslahus, 12% aktiivkloor	40	A
pleegituslahus, 12% aktiivkloor	60	B
propaan	20	A
propanool	60	A
püridiin	20	A
puutõrv	20	C
rääs	20	A
riitsinusõli	60	A
rodaniidid (ammoonium- jt)	60	A
salitsüülhape	20	A
salpeeterhape 25%	20	A
salpeeterhape 25%	60	B
salpeeterhape 50%	20	A
salpeeterhape 50%	50	B
salpeeterhape 95%	20	C
searav	20	A
seebilahus	40	A

A = talub väga hästi  
B = keskmine vastupidavus  
C = ei talu

Medium	Temp. °C	VASTUPIDAV US
seebirasv	60	A
sidrunihape	20	A
sidrunihape	60	B
silikaadid (K-)	20	A
sipelghape 100%	20	B
sipelghape 100%	60	C
sipelghape 50%	40	A
soolhape kuni 30%	20	A
soolhape kuni 30%	60	B
soolhape kuni 37%	20	A
soolhape kuni 37%	40	B
soolvesi	60	A
steariinhape	60	A
sulfaadid (ammoonium-, Na- jne)	60	A
sulfiidid (ammoonium-, Na- jne)	60	A
süsinikdioksiid	60	A
süsinikdisulfiid 100%	20	B
süsinikmonooksiid	60	A
taimeõlid	40	A
tärpentin	20	A
tetraetüülplii	60	A
tetrahüdrofuraan	20	C
toluool	20	A
tõrv, aromaadivaba	20	A
trafoõli	60	A
triklooretüleen	20	C
tsitraadid (ammoonium-, Na)	20	A
tsüaanäädikhape	20	C
tsüaanamiid	20	A
tsüaanvesinikhape	40	A
tsüaniidid (K-, Na- kuni 50%)	60	A
tsükloheksanool	20	C
tsükloheksanoon	20	C
vääveldioksiid, gaasiline, kuiv ja niiske 100%	60	A
väävelhape kuni 40%	20	C
väävelhape kuni 50%	50	A
väävelhape kuni 50%	60	A
väävelhape kuni 80%	40	C
väävelhape kuni 80%	60	B
väävelhape kuni 96%	20	A
väävelhape kuni 96%	60	B
väävelhape, suitsev (10%line ooleum)	20	C
väävelvesinik	60	A
väävliishape	60	A
valgustusgaas	20	A
vein	40	A
veiniäädikas	50	A
veinihape	60	A
veri	40	A
vesi	40	A
vesi	60	B
vesinikfluoriid kuni 40%	40	A
vesinikfluoriid kuni 40%	60	B
vesinikperoksiid kuni 30%	60	A
vesinikperoksiid kuni 90%	20	A
viinamarjasuhkur	50	A
vinüülatsetaat	20	C
viskoosliimained	60	A
võihape 100%	20	C
võihape 20%	20	A
võihape 20%	60	C
võipiim	20	A
želatiin	60	A





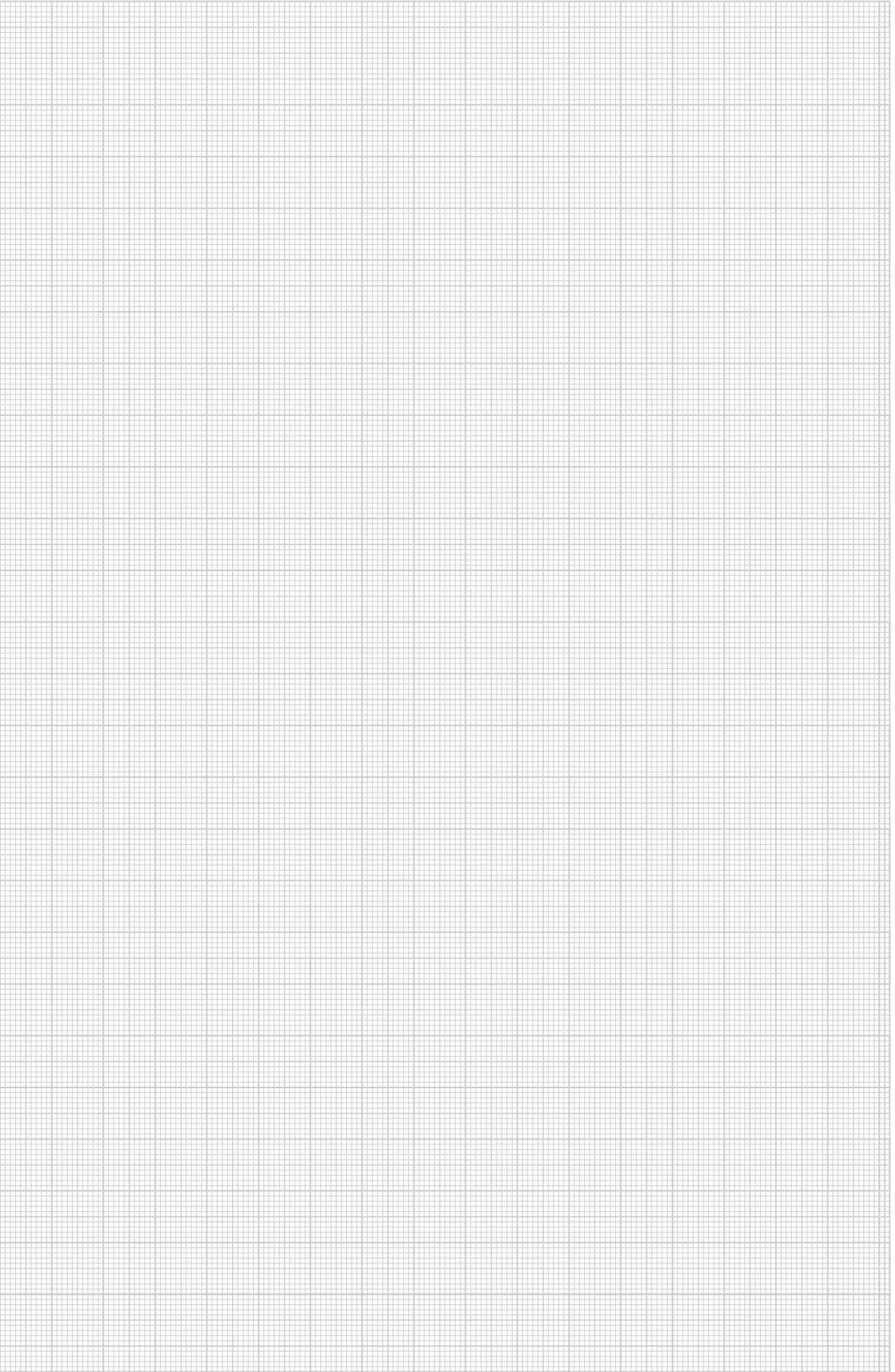

Kasutatava kõva PVC materjalomadused  
Materjali tähis vastavalt standardile DIN 7748 PVC-U-E-D-080-04-28  
Tõmbekindlus vastavalt standardile DIN 53 455 min 40 N/mm<sup>2</sup>  
Katkevenivus vastavalt standardile DIN 53 455 min 65%  
Läbilöögikindlus vastavalt standardile DIN 53 481 min 20 KV/mm  
Pinnatakistus vastavalt standardile DIN 53 482 min 10 10  
Soojuskindlus vastavalt standardile DIN 53 460/B min 75 °C  
Rakenduse temperatuurikindlus max 65 °C  
Süttivus vastavalt UL 94 tase V-0  
Hõõgniidi kontroll vastavalt standardile DIN IEC 695 960 °C  
Ehitusmaterjaliklass vastavalt standardile DIN EN 4102, klass B1 ja B2







## VK traadistuskarbikusüsteem, süsteem Dahl

	LK4 traadistuskarbik	15 x 15 mm kuni 80 x 120 mm	164
	LK4/N traadistuskarbik koos traadihoidikuga	60 x 15 mm kuni 80 x 120 mm	170
	LKV DIN traadistuskarbik	25 x 25 mm kuni 100 x 100 mm	174
	LKV/N DIN traadistuskarbik koos traadihoidikuga	75 x 25 mm kuni 100 x 100 mm	179
	LKV/H DIN traadistuskarbik, halogeenivaba	50 x 37 mm kuni 75 x 125 mm	182
	Lisavarustus	juhtmehoidja	184
		tööriist plastfiksaatori paigaldamiseks	184
		lõiketangid	184
		distantsihoidja	185
		kandelatt	185
		DIN-latt	185



# LK4 traadistuskarbik

VK traadistuskarbik, süsteem Dahl



## Traadistuskarbik, tüüp LK4 15015

Tüüp	värv	Pikkus mm	Mõõde B x H mm	Pak. m	kaal kg/100 m	Toote nr
LK4 15015	kivihall	2000	15x15	72	12,000	6178 00 1

PVC Polüvinüülkloriid

€/m

Traadistuskarbik põhjaperforatsiooni ja kaanega.

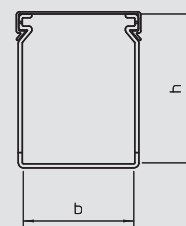

## Kaas

Tüüp	värv	Mõõt a mm	Pikkus mm	Pak. m	kaal kg/100 m	Toote nr
LK4 DM 15	kivihall	15	2000	92	8,500	6178 47 9

PVC Polüvinüülkloriid

€/m

Karbiku kaas asendamiseks.

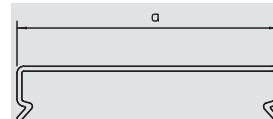

## Traadistuskarbik, tüüp LK4 30015

Tüüp	värv	Pikkus mm	Mõõde B x H mm	Pak. m	kaal kg/100 m	Toote nr
LK4 30015	kivihall	2000	15x30	40	18,000	6178 00 3

PVC Polüvinüülkloriid

€/m

Traadistuskarbik põhjaperforatsiooni ja kaanega.

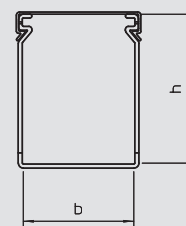

## Kaas

Tüüp	värv	Mõõt a mm	Pikkus mm	Pak. m	kaal kg/100 m	Toote nr
LK4 D 15	kivihall	15	2000	92	8,500	6178 48 0

PVC Polüvinüülkloriid

€/m

Karbiku kaas asendamiseks.

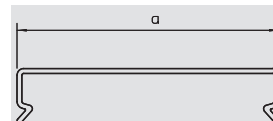

## Traadistuskarbik, tüüp LK4 30025

Tüüp	värv	Pikkus mm	Mõõde B x H mm	Pak. m	kaal kg/100 m	Toote nr
LK4 30025	kivihall	2000	25x30	48	28,000	6178 00 5

PVC Polüvinüülkloriid

€/m

Traadistuskarbik põhjaperforatsiooni ja kaanega.

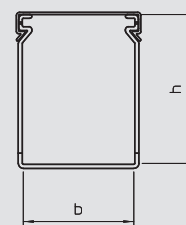

## Kaas

Tüüp	värv	Mõõt a mm	Pikkus mm	Pak. m	kaal kg/100 m	Toote nr
LK4 D 25	kivihall	25	2000	32	10,000	6178 48 2

PVC Polüvinüülkloriid

€/m

Karbiku kaas asendamiseks.

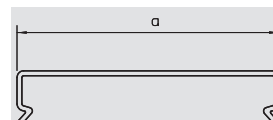

## Traadistuskarbik, tüüp LK4 40025

Tüüp	värv	Pikkus mm	Mõõde B x H mm	Pak. m	kaal kg/100 m	Toote nr
LK4 40025	kivihall	2000	25x40	48	36,500	6178 01 0

PVC Polüvinüülkloriid

€/m

Traadistuskarbik põhjaperforatsiooni ja kaanega.

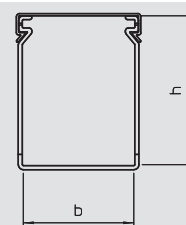

## Kaas

Tüüp	värv	Mõõt a mm	Pikkus mm	Pak. m	kaal kg/100 m	Toote nr
LK4 D 25	kivihall	25	2000	32	10,000	6178 48 2

PVC Polüvinüülkloriid

€/m

Karbiku kaas asendamiseks.

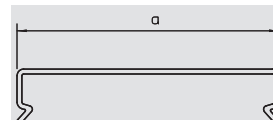

06 LFS\_Katalog\_2010\_Neuer\_Stand / et / 25/07/2011 (LLExport\_01306)

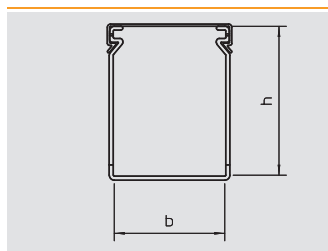

## Traadistuskarbik, tüüp LK4 40040

Tüüp	värv	Pikkus mm	Mõõde B x H mm	Pak. m	kaal kg/100 m	Toote nr
<b>LK4 40040</b>	kivihall	2000	40x40	36	44,000	<b>6178 01 2</b>

**PVC** Polüvinüülkloriid €/m

Traadistuskarbik põhjaperforatsiooni ja kaanega.

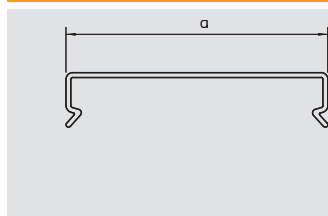

## Kaas

Tüüp	värv	Mõõt a mm	Pikkus mm	Pak. m	kaal kg/100 m	Toote nr
<b>LK4 D 40</b>	kivihall	40	2000	24	13,500	<b>6178 48 4</b>

**PVC** Polüvinüülkloriid €/m

Karbiku kaas asendamiseks.

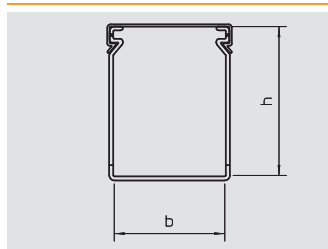

## Traadistuskarbik, tüüp LK4 40060

Tüüp	värv	Pikkus mm	Mõõde B x H mm	Pak. m	kaal kg/100 m	Toote nr
<b>LK4 40060</b>	kivihall	2000	60x40	24	57,000	<b>6178 01 4</b>

**PVC** Polüvinüülkloriid €/m

Traadistuskarbik põhjaperforatsiooni ja kaanega.

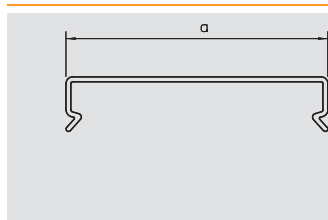

## Kaas

Tüüp	värv	Mõõt a mm	Pikkus mm	Pak. m	kaal kg/100 m	Toote nr
<b>LK4 D 60</b>	kivihall	60	2000	40	18,000	<b>6178 48 6</b>

**PVC** Polüvinüülkloriid €/m

Karbiku kaas asendamiseks.

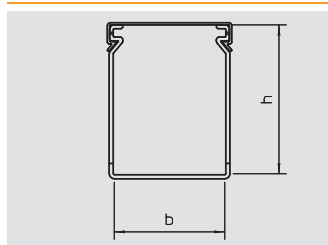

## Traadistuskarbik, tüüp LK4 40080

Tüüp	värv	Pikkus mm	Mõõde B x H mm	Pak. m	kaal kg/100 m	Toote nr
<b>LK4 40080</b>	kivihall	2000	80x40	24	71,000	<b>6178 01 6</b>

**PVC** Polüvinüülkloriid €/m

Traadistuskarbik põhjaperforatsiooni ja kaanega.

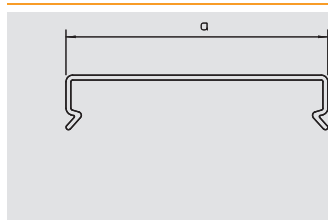

## Kaas

Tüüp	värv	Mõõt a mm	Pikkus mm	Pak. m	kaal kg/100 m	Toote nr
<b>LK4 D 80</b>	kivihall	80	2000	12	27,000	<b>6178 48 8</b>

**PVC** Polüvinüülkloriid €/m

Karbiku kaas asendamiseks.

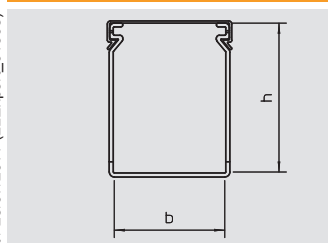

## Traadistuskarbik, tüüp LK4 40100

Tüüp	värv	Pikkus mm	Mõõde B x H mm	Pak. m	kaal kg/100 m	Toote nr
<b>LK4 40100</b>	kivihall	2000	100x40	24	85,500	<b>6178 01 8</b>

**PVC** Polüvinüülkloriid €/m

Traadistuskarbik põhjaperforatsiooni ja kaanega.

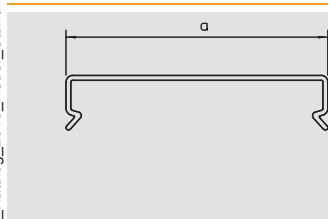

## Kaas

Tüüp	värv	Mõõt a mm	Pikkus mm	Pak. m	kaal kg/100 m	Toote nr
<b>LK4 D 100</b>	kivihall	100	2000	12	35,500	<b>6178 49 0</b>

**PVC** Polüvinüülkloriid €/m

Karbiku kaas asendamiseks.



# LK4 traadistuskarbik

VK traadistuskarbik, süsteem Dahl



## Traadistuskarbik, tüüp LK4 60015

Tüüp	värv	Pikkus mm	Mõõde B x H mm	Pak. m	kaal kg/100 m	Toote nr
<b>LK4 60015</b>	kivihall	2000	15x60	48	32,500	<b>6178 02 6</b>

**PVC** Polüvinüülkloriid € / m

Traadistuskarbik põhjaperforatsiooni ja kaanega.

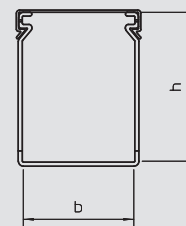

## Kaas

Tüüp	värv	Mõõt a mm	Pikkus mm	Pak. m	kaal kg/100 m	Toote nr
<b>LK4 D 15</b>	kivihall	15	2000	92	8,500	<b>6178 48 0</b>

**PVC** Polüvinüülkloriid € / m

Karbiku kaas asendamiseks.

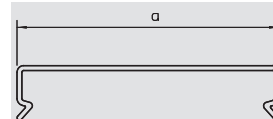

## Traadistuskarbik, tüüp LK4 60025

Tüüp	värv	Pikkus mm	Mõõde B x H mm	Pak. m	kaal kg/100 m	Toote nr
<b>LK4 60025</b>	kivihall	2000	25x60	32	46,000	<b>6178 02 8</b>

**PVC** Polüvinüülkloriid € / m

Traadistuskarbik põhjaperforatsiooni ja kaanega.

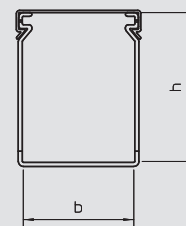

## Kaas

Tüüp	värv	Mõõt a mm	Pikkus mm	Pak. m	kaal kg/100 m	Toote nr
<b>LK4 D 25</b>	kivihall	25	2000	32	10,000	<b>6178 48 2</b>

**PVC** Polüvinüülkloriid € / m

Karbiku kaas asendamiseks.

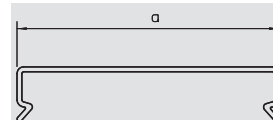

## Traadistuskarbik, tüüp LK4 60040

Tüüp	värv	Pikkus mm	Mõõde B x H mm	Pak. m	kaal kg/100 m	Toote nr
<b>LK4 60040</b>	kivihall	2000	40x60	24	53,500	<b>6178 03 1</b>

**PVC** Polüvinüülkloriid € / m

Traadistuskarbik põhjaperforatsiooni ja kaanega.

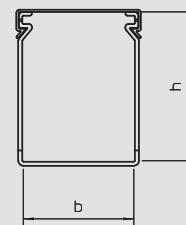

## Kaas

Tüüp	värv	Mõõt a mm	Pikkus mm	Pak. m	kaal kg/100 m	Toote nr
<b>LK4 D 40</b>	kivihall	40	2000	24	13,500	<b>6178 48 4</b>

**PVC** Polüvinüülkloriid € / m

Karbiku kaas asendamiseks.

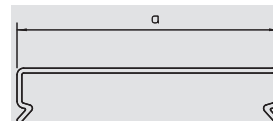

## Traadistuskarbik, tüüp LK4 60060

Tüüp	värv	Pikkus mm	Mõõde B x H mm	Pak. m	kaal kg/100 m	Toote nr
<b>LK4 60060</b>	kivihall	2000	60x60	32	64,500	<b>6178 03 3</b>

**PVC** Polüvinüülkloriid € / m

Traadistuskarbik põhjaperforatsiooni ja kaanega.

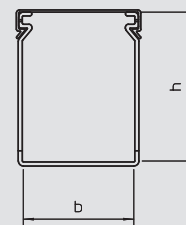

## Kaas

Tüüp	värv	Mõõt a mm	Pikkus mm	Pak. m	kaal kg/100 m	Toote nr
<b>LK4 D 60</b>	kivihall	60	2000	40	18,000	<b>6178 48 6</b>

**PVC** Polüvinüülkloriid € / m

Karbiku kaas asendamiseks.

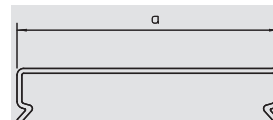

06 LFS\_Katalog\_2010\_Neuer\_Stand / et / 25/07/2011 (LLExport\_01306)

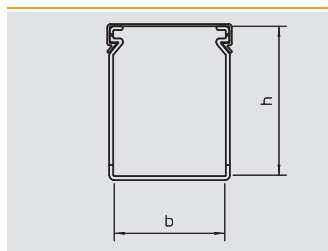

## Traadistuskarbiik, tüüp LK4 60080

Tüüp	värv	Pikkus mm	Mõõde B x H mm	Pak. m	kaal kg/100 m	Toote nr
<b>LK4 60080</b>	kivihall	2000	80x60	24	82,500	<b>6178 03 5</b>

**PVC** Polüvinüülkloriid

€/m

Traadistuskarbiik põhjaperforatsiooni ja kaanega.

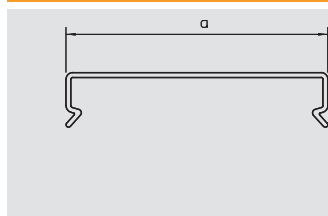

## Kaas

Tüüp	värv	Mõõt a mm	Pikkus mm	Pak. m	kaal kg/100 m	Toote nr
<b>LK4 D 80</b>	kivihall	80	2000	12	27,000	<b>6178 48 8</b>

**PVC** Polüvinüülkloriid

€/m

Karbiiku kaas asendamiseks.

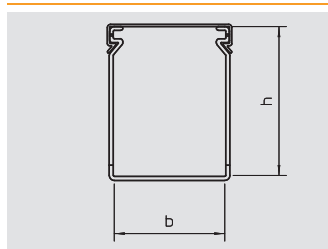

## Traadistuskarbiik, tüüp LK4 60100

Tüüp	värv	Pikkus mm	Mõõde B x H mm	Pak. m	kaal kg/100 m	Toote nr
<b>LK4 60100</b>	kivihall	2000	100x60	16	100,000	<b>6178 03 7</b>

**PVC** Polüvinüülkloriid

€/m

Traadistuskarbiik põhjaperforatsiooni ja kaanega.

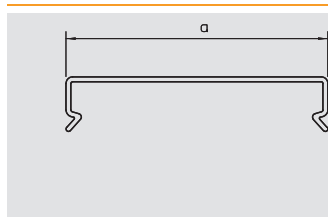
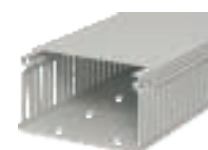

## Kaas

Tüüp	värv	Mõõt a mm	Pikkus mm	Pak. m	kaal kg/100 m	Toote nr
<b>LK4 D 100</b>	kivihall	100	2000	12	35,500	<b>6178 49 0</b>

**PVC** Polüvinüülkloriid

€/m

Karbiiku kaas asendamiseks.

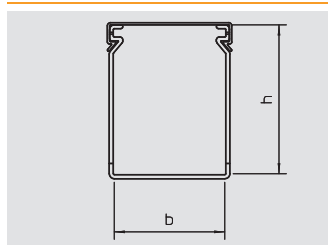

## Traadistuskarbiik, tüüp LK4 60120

Tüüp	värv	Pikkus mm	Mõõde B x H mm	Pak. m	kaal kg/100 m	Toote nr
<b>LK4 60120</b>	kivihall	2000	120x60	8	117,000	<b>6178 03 9</b>

**PVC** Polüvinüülkloriid

€/m

Traadistuskarbiik põhjaperforatsiooni ja kaanega.

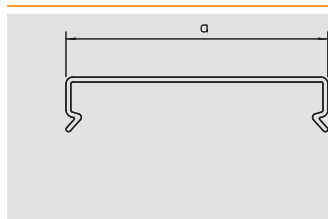

## Kaas

Tüüp	värv	Mõõt a mm	Pikkus mm	Pak. m	kaal kg/100 m	Toote nr
<b>LK4 D 120</b>	kivihall	120	2000	16	45,500	<b>6178 49 2</b>

**PVC** Polüvinüülkloriid

€/m

Karbiiku kaas asendamiseks.

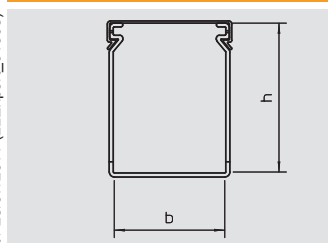

## Traadistuskarbiik, tüüp LK4 80025

Tüüp	värv	Pikkus mm	Mõõde B x H mm	Pak. m	kaal kg/100 m	Toote nr
<b>LK4 80025</b>	kivihall	2000	25x80	32	61,000	<b>6178 05 0</b>

**PVC** Polüvinüülkloriid

€/m

Traadistuskarbiik põhjaperforatsiooni ja kaanega.

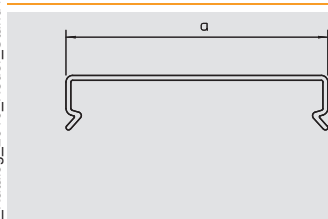

## Kaas

Tüüp	värv	Mõõt a mm	Pikkus mm	Pak. m	kaal kg/100 m	Toote nr
<b>LK4 D 25</b>	kivihall	25	2000	32	10,000	<b>6178 48 2</b>

**PVC** Polüvinüülkloriid

€/m

Karbiiku kaas asendamiseks.



# LK4 traadistuskarbik

VK traadistuskarbik, süsteem Dahl



## Traadistuskarbik, tüüp LK4 80040

Tüüp	värv	Pikkus mm	Mõõde B x H mm	Pak. m	kaal kg/100 m	Toote nr
<b>LK4 80040</b>	kivihall	2000	40x80	24	64,500	<b>6178 05 2</b>

**PVC** Polüvinüülkloriid € / m

Traadistuskarbik põhjaperforatsiooni ja kaanega.

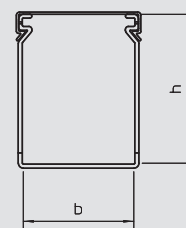

## Kaas

Tüüp	värv	Mõõt a mm	Pikkus mm	Pak. m	kaal kg/100 m	Toote nr
<b>LK4 D 40</b>	kivihall	40	2000	24	13,500	<b>6178 48 4</b>

**PVC** Polüvinüülkloriid € / m

Karbiku kaas asendamiseks.

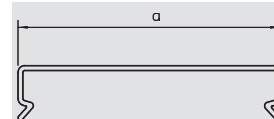

## Traadistuskarbik, tüüp LK4 80060

Tüüp	värv	Pikkus mm	Mõõde B x H mm	Pak. m	kaal kg/100 m	Toote nr
<b>LK4 80060</b>	kivihall	2000	60x80	24	76,000	<b>6178 05 4</b>

**PVC** Polüvinüülkloriid € / m

Traadistuskarbik põhjaperforatsiooni ja kaanega.

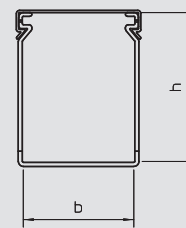

## Kaas

Tüüp	värv	Mõõt a mm	Pikkus mm	Pak. m	kaal kg/100 m	Toote nr
<b>LK4 D 60</b>	kivihall	60	2000	40	18,000	<b>6178 48 6</b>

**PVC** Polüvinüülkloriid € / m

Karbiku kaas asendamiseks.

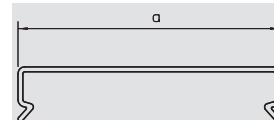

## Traadistuskarbik, tüüp LK4 80080

Tüüp	värv	Pikkus mm	Mõõde B x H mm	Pak. m	kaal kg/100 m	Toote nr
<b>LK4 80080</b>	kivihall	2000	80x80	16	95,500	<b>6178 05 6</b>

**PVC** Polüvinüülkloriid € / m

Traadistuskarbik põhjaperforatsiooni ja kaanega.

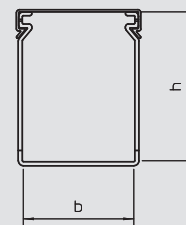

## Kaas

Tüüp	värv	Mõõt a mm	Pikkus mm	Pak. m	kaal kg/100 m	Toote nr
<b>LK4 D 80</b>	kivihall	80	2000	12	27,000	<b>6178 48 8</b>

**PVC** Polüvinüülkloriid € / m

Karbiku kaas asendamiseks.

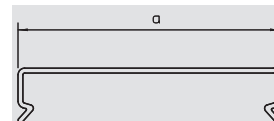

## Traadistuskarbik, tüüp LK4 80100

Tüüp	värv	Pikkus mm	Mõõde B x H mm	Pak. m	kaal kg/100 m	Toote nr
<b>LK4 80100</b>	kivihall	2000	100x80	16	111,500	<b>6178 05 9</b>

**PVC** Polüvinüülkloriid € / m

Traadistuskarbik põhjaperforatsiooni ja kaanega.

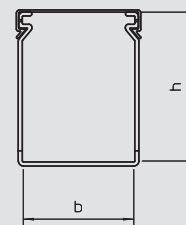

## Kaas

Tüüp	värv	Mõõt a mm	Pikkus mm	Pak. m	kaal kg/100 m	Toote nr
<b>LK4 D 100</b>	kivihall	100	2000	12	35,500	<b>6178 49 0</b>

**PVC** Polüvinüülkloriid € / m

Karbiku kaas asendamiseks.

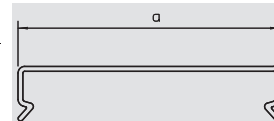

06 LFS\_Katalog\_2010\_Neuer\_Stand / et / 25/07/2011 (LLE.Export\_01306)

## LK4 traadistuskarbik

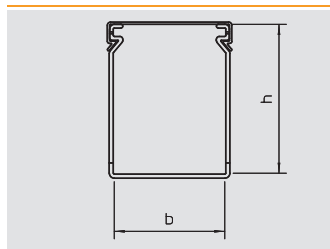

### Traadistuskarbik, tüüp LK4 80120

Tüüp	värv	Pikkus mm	Mõõde B x H mm	Pak. m	kaal kg/100 m	Toote nr
<b>LK4 80120</b>	kivihall	2000	120x80	8	128,500	<b>6178 06 1</b>

PVC Polüvinüülkloriid

€/m

Traadistuskarbik põhjaperforatsiooni ja kaanega.

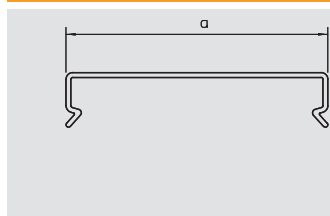

### Kaas

Tüüp	värv	Mõõt a mm	Pikkus mm	Pak. m	kaal kg/100 m	Toote nr
<b>LK4 D 120</b>	kivihall	120	2000	16	45,500	<b>6178 49 2</b>

PVC Polüvinüülkloriid

€/m

Karbiku kaas asendamiseks.



VK traadistuskarbik, süsteem Dahl



# LK4/N traadistuskarbik

VK traadistuskarbik, süsteem Dahl



## Traadistuskarbik, tüüp LK4/N 60015

Tüüp	värv	Pikkus mm	Mõõde B x H mm	Pak. m	kaal kg/100 m	Toote nr
<b>LK4 N 60015</b>	kivihall	2000	15x60	48	41,000	<b>6178 20 1</b>

**PVC** Polüvinüülkloriid

€/m

Traadistuskarbik põhjaperforatsiooni ja kaanega, reljeef küljepiludes juhtmete väljakukkumise takistamiseks.

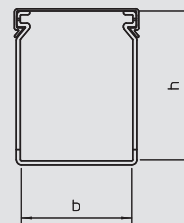

## Kaas

Tüüp	värv	Mõõt a mm	Pikkus mm	Pak. m	kaal kg/100 m	Toote nr
<b>LK4 D 15</b>	kivihall	15	2000	92	8,500	<b>6178 48 0</b>

**PVC** Polüvinüülkloriid

€/m

Karbiku kaas asendamiseks.

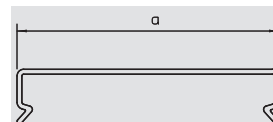

## Traadistuskarbik, tüüp LK4/N 60025

Tüüp	värv	Pikkus mm	Mõõde B x H mm	Pak. m	kaal kg/100 m	Toote nr
<b>LK4 N 60025</b>	kivihall	2000	25x60	32	48,500	<b>6178 20 3</b>

**PVC** Polüvinüülkloriid

€/m

Traadistuskarbik põhjaperforatsiooni ja kaanega, reljeef küljepiludes juhtmete väljakukkumise takistamiseks.

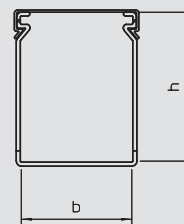

## Kaas

Tüüp	värv	Mõõt a mm	Pikkus mm	Pak. m	kaal kg/100 m	Toote nr
<b>LK4 D 25</b>	kivihall	25	2000	32	10,000	<b>6178 48 2</b>

**PVC** Polüvinüülkloriid

€/m

Karbiku kaas asendamiseks.

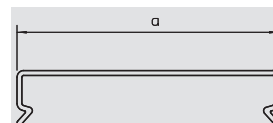

## Traadistuskarbik, tüüp LK4/N 60040

Tüüp	värv	Pikkus mm	Mõõde B x H mm	Pak. m	kaal kg/100 m	Toote nr
<b>LK4 N 60040</b>	kivihall	2000	40x60	24	56,000	<b>6178 20 5</b>

**PVC** Polüvinüülkloriid

€/m

Traadistuskarbik põhjaperforatsiooni ja kaanega, reljeef küljepiludes juhtmete väljakukkumise takistamiseks.

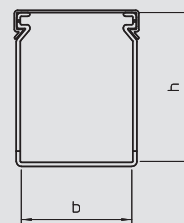

## Kaas

Tüüp	värv	Mõõt a mm	Pikkus mm	Pak. m	kaal kg/100 m	Toote nr
<b>LK4 D 40</b>	kivihall	40	2000	24	13,500	<b>6178 48 4</b>

**PVC** Polüvinüülkloriid

€/m

Karbiku kaas asendamiseks.

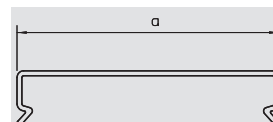

## Traadistuskarbik, tüüp LK4/N 60060

Tüüp	värv	Pikkus mm	Mõõde B x H mm	Pak. m	kaal kg/100 m	Toote nr
<b>LK4 N 60060</b>	kivihall	2000	60x60	32	68,000	<b>6178 20 7</b>

**PVC** Polüvinüülkloriid

€/m

Traadistuskarbik põhjaperforatsiooni ja kaanega, reljeef küljepiludes juhtmete väljakukkumise takistamiseks.

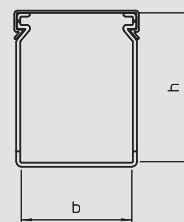

## Kaas

Tüüp	värv	Mõõt a mm	Pikkus mm	Pak. m	kaal kg/100 m	Toote nr
<b>LK4 D 60</b>	kivihall	60	2000	40	18,000	<b>6178 48 6</b>

**PVC** Polüvinüülkloriid

€/m

Karbiku kaas asendamiseks.

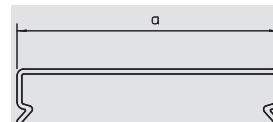

06 LFS\_Katalog\_2010\_Neuer\_Stand / et / 25/07/2011 (LLE.Export\_01305)

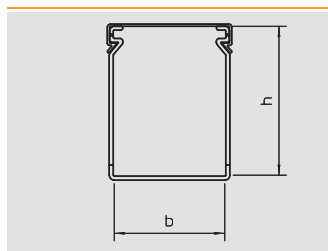

## Traadistuskarbiik, tüüp LK4/N 60080

Tüüp	värv	Pikkus mm	Mõõde B x H mm	Pak. m	kaal kg/100 m	Toote nr
<b>LK4 N 60080</b>	kivihall	2000	80x60	24	87,000	<b>6178 20 9</b>

**PVC** Polüvinüülkloriid € / m

Traadistuskarbiik põhjaperforatsiooni ja kaanega, reljeef küljepiludes juhtmete väljakukkumise takistamiseks.

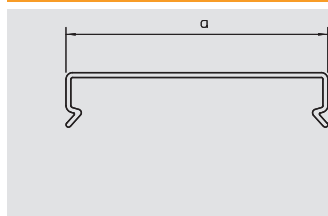

## Kaas

Tüüp	värv	Mõõt a mm	Pikkus mm	Pak. m	kaal kg/100 m	Toote nr
<b>LK4 D 80</b>	kivihall	80	2000	12	27,000	<b>6178 48 8</b>

**PVC** Polüvinüülkloriid € / m

Karbiiku kaas asendamiseks.

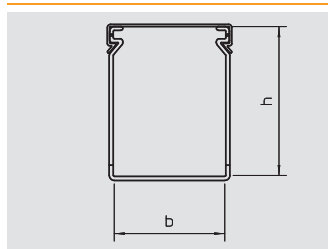

## Traadistuskarbiik, tüüp LK4/N 60100

Tüüp	värv	Pikkus mm	Mõõde B x H mm	Pak. m	kaal kg/100 m	Toote nr
<b>LK4 N 60100</b>	kivihall	2000	100x60	16	105,500	<b>6178 21 1</b>

**PVC** Polüvinüülkloriid € / m

Traadistuskarbiik põhjaperforatsiooni ja kaanega, reljeef küljepiludes juhtmete väljakukkumise takistamiseks.

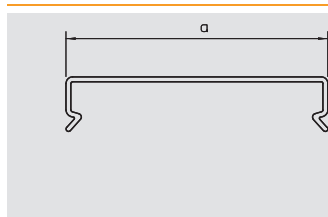

## Kaas

Tüüp	värv	Mõõt a mm	Pikkus mm	Pak. m	kaal kg/100 m	Toote nr
<b>LK4 D 100</b>	kivihall	100	2000	12	35,500	<b>6178 49 0</b>

**PVC** Polüvinüülkloriid € / m

Karbiiku kaas asendamiseks.

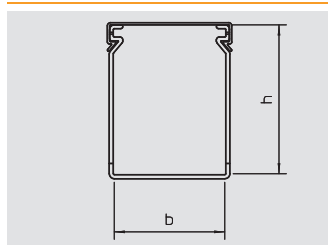

## Traadistuskarbiik, tüüp LK4/N 60120

Tüüp	värv	Pikkus mm	Mõõde B x H mm	Pak. m	kaal kg/100 m	Toote nr
<b>LK4 N 60120</b>	kivihall	2000	120x60	8	120,500	<b>6178 21 3</b>

**PVC** Polüvinüülkloriid € / m

Traadistuskarbiik põhjaperforatsiooni ja kaanega, reljeef küljepiludes juhtmete väljakukkumise takistamiseks.

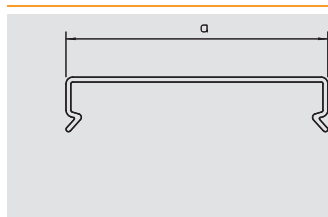

## Kaas

Tüüp	värv	Mõõt a mm	Pikkus mm	Pak. m	kaal kg/100 m	Toote nr
<b>LK4 D 120</b>	kivihall	120	2000	16	45,500	<b>6178 49 2</b>

**PVC** Polüvinüülkloriid € / m

Karbiiku kaas asendamiseks.

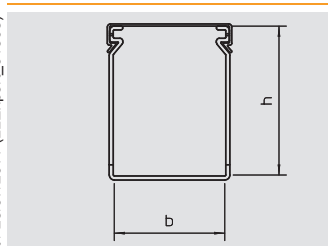

## Traadistuskarbiik, tüüp LK4/N 80025

Tüüp	värv	Pikkus mm	Mõõde B x H mm	Pak. m	kaal kg/100 m	Toote nr
<b>LK4 N 80025</b>	kivihall	2000	25x80	32	65,000	<b>6178 22 5</b>

**PVC** Polüvinüülkloriid € / m

Traadistuskarbiik põhjaperforatsiooni ja kaanega, reljeef küljepiludes juhtmete väljakukkumise takistamiseks.

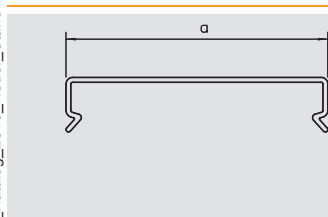

## Kaas

Tüüp	värv	Mõõt a mm	Pikkus mm	Pak. m	kaal kg/100 m	Toote nr
<b>LK4 D 25</b>	kivihall	25	2000	32	10,000	<b>6178 48 2</b>

**PVC** Polüvinüülkloriid € / m

Karbiiku kaas asendamiseks.



# LK4/N traadistuskarbik

VK traadistuskarbik, süsteem Dahl



## Traadistuskarbik, tüüp LK4/N 80040

Tüüp	värv	Pikkus mm	Mõõde B x H mm	Pak. m	kaal kg/100 m	Toote nr
<b>LK4 N 80040</b>	kivihall	2000	40x80	24	73,500	<b>6178 22 7</b>

**PVC** Polüvinüülkloriid € / m

Traadistuskarbik põhjaperforatsiooni ja kaanega, reljeef küljepiludes juhtmete väljakukkumise takistamiseks.

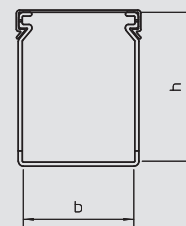

## Kaas

Tüüp	värv	Mõõt a mm	Pikkus mm	Pak. m	kaal kg/100 m	Toote nr
<b>LK4 D 40</b>	kivihall	40	2000	24	13,500	<b>6178 48 4</b>

**PVC** Polüvinüülkloriid € / m

Karbiku kaas asendamiseks.

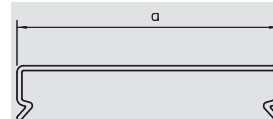

## Traadistuskarbik, tüüp LK4/N 80060

Tüüp	värv	Pikkus mm	Mõõde B x H mm	Pak. m	kaal kg/100 m	Toote nr
<b>LK4 N 80060</b>	kivihall	2000	60x80	24	82,000	<b>6178 22 9</b>

**PVC** Polüvinüülkloriid € / m

Traadistuskarbik põhjaperforatsiooni ja kaanega, reljeef küljepiludes juhtmete väljakukkumise takistamiseks.

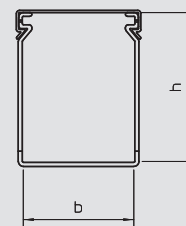

## Kaas

Tüüp	värv	Mõõt a mm	Pikkus mm	Pak. m	kaal kg/100 m	Toote nr
<b>LK4 D 60</b>	kivihall	60	2000	40	18,000	<b>6178 48 6</b>

**PVC** Polüvinüülkloriid € / m

Karbiku kaas asendamiseks.

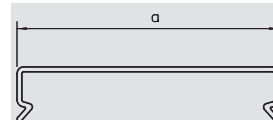

## Traadistuskarbik, tüüp LK4/N 80080

Tüüp	värv	Pikkus mm	Mõõde B x H mm	Pak. m	kaal kg/100 m	Toote nr
<b>LK4 N 80080</b>	kivihall	2000	80x80	16	101,000	<b>6178 23 1</b>

**PVC** Polüvinüülkloriid € / m

Traadistuskarbik põhjaperforatsiooni ja kaanega, reljeef küljepiludes juhtmete väljakukkumise takistamiseks.

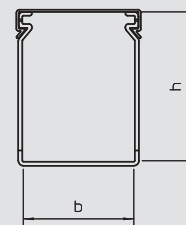

## Kaas

Tüüp	värv	Mõõt a mm	Pikkus mm	Pak. m	kaal kg/100 m	Toote nr
<b>LK4 D 80</b>	kivihall	80	2000	12	27,000	<b>6178 48 8</b>

**PVC** Polüvinüülkloriid € / m

Karbiku kaas asendamiseks.

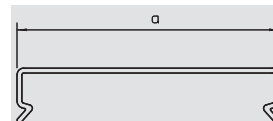

## Traadistuskarbik, tüüp LK4/N 80100

Tüüp	värv	Pikkus mm	Mõõde B x H mm	Pak. m	kaal kg/100 m	Toote nr
<b>LK4 N 80100</b>	kivihall	2000	100x80	16	116,500	<b>6178 23 3</b>

**PVC** Polüvinüülkloriid € / m

Traadistuskarbik põhjaperforatsiooni ja kaanega, reljeef küljepiludes juhtmete väljakukkumise takistamiseks.

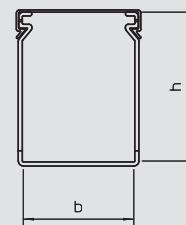

## Kaas

Tüüp	värv	Mõõt a mm	Pikkus mm	Pak. m	kaal kg/100 m	Toote nr
<b>LK4 D 100</b>	kivihall	100	2000	12	35,500	<b>6178 49 0</b>

**PVC** Polüvinüülkloriid € / m

Karbiku kaas asendamiseks.

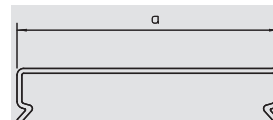

06 LFS\_Katalog\_2010\_Neuer\_Stand / et / 25/07/2011 (LL.Export\_01305)

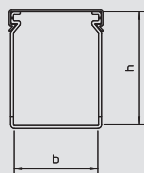

## Traadistuskarbik, tüüp LK4/N 80120

Tüüp	värv	Pikkus mm	Mõõde B x H mm	Pak. m	kaal kg/100 m	Toote nr
<b>LK4 N 80120</b>	kivihall	2000	120x80	8	133,500	<b>6178 23 6</b>

PVC Polüvinüülkloriid € /m

Traadistuskarbik põhjaperforatsiooni ja kaanega, reljeef küljepiludes juhtmete väljakukkumise takistamiseks.

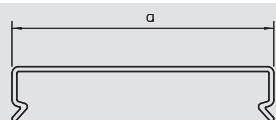

## Kaas

Tüüp	värv	Mõõt a mm	Pikkus mm	Pak. m	kaal kg/100 m	Toote nr
<b>LK4 D 120</b>	kivihall	120	2000	16	45,500	<b>6178 49 2</b>

PVC Polüvinüülkloriid € /m

Karbiku kaas asendamiseks.



# LKV DIN traadistuskarbik

VK traadistuskarbik, süsteem Dahl



## Traadistuskarbik, tüüp 25025

Tüüp	värv	Pikkus mm	Mõõde B x H mm	Pak. m	kaal kg/100 m	Toote nr
LKV 25025	kivihall	2000	25x25	32	24,000	6178 30 2

PVC Polüvinüülkloriid

€/m

Traadistuskarbik põhjaperforatsiooni ja kaanega vastavalt standardile DIN EN 50085-2-3.

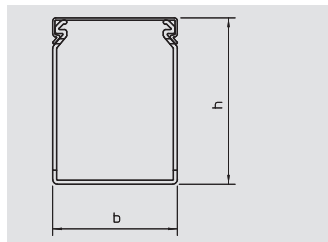

## Kaas

Tüüp	värv	Mõõt a mm	Pikkus mm	Pak. m	kaal kg/100 m	Toote nr
LKV D 25	kivihall	25	2000	36	9,500	6178 50 4

PVC Polüvinüülkloriid

€/m

Karbiku kaas asendamiseks.

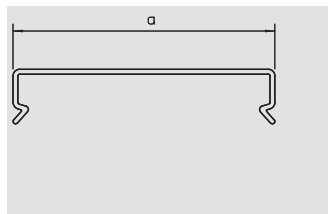

## Traadistuskarbik, tüüp 37025

Tüüp	värv	Pikkus mm	Mõõde B x H mm	Pak. m	kaal kg/100 m	Toote nr
LKV 37025	kivihall	2000	25x37,5	32	31,500	6178 30 5

PVC Polüvinüülkloriid

€/m

Traadistuskarbik põhjaperforatsiooni ja kaanega vastavalt standardile DIN EN 50085-2-3.

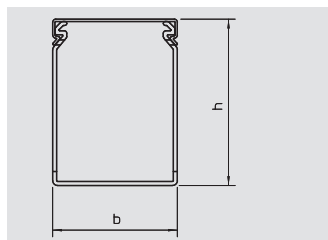

## Kaas

Tüüp	värv	Mõõt a mm	Pikkus mm	Pak. m	kaal kg/100 m	Toote nr
LKV D 25	kivihall	25	2000	36	9,500	6178 50 4

PVC Polüvinüülkloriid

€/m

Karbiku kaas asendamiseks.

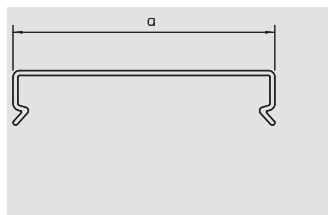

## Traadistuskarbik, tüüp 37037

Tüüp	värv	Pikkus mm	Mõõde B x H mm	Pak. m	kaal kg/100 m	Toote nr
LKV 37037	kivihall	2000	37,5x37,5	60	40,500	6178 30 7

PVC Polüvinüülkloriid

€/m

Traadistuskarbik põhjaperforatsiooni ja kaanega vastavalt standardile DIN EN 50085-2-3.

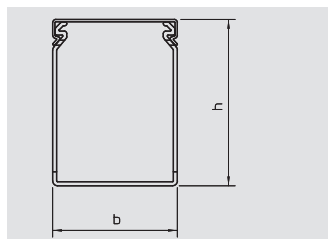

## Kaas

Tüüp	värv	Mõõt a mm	Pikkus mm	Pak. m	kaal kg/100 m	Toote nr
LKV D 37	kivihall	37,5	2000	24	15,000	6178 50 6

PVC Polüvinüülkloriid

€/m

Karbiku kaas asendamiseks.

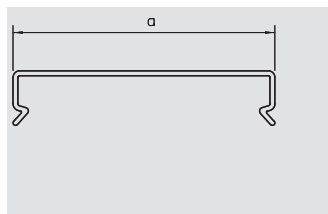

## Traadistuskarbik, tüüp 50025

Tüüp	värv	Pikkus mm	Mõõde B x H mm	Pak. m	kaal kg/100 m	Toote nr
LKV 50025	kivihall	2000	25x50	60	35,500	6178 31 0

PVC Polüvinüülkloriid

€/m

Traadistuskarbik põhjaperforatsiooni ja kaanega vastavalt standardile DIN EN 50085-2-3.

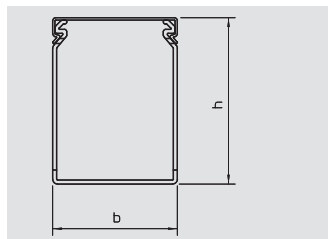

## Kaas

Tüüp	värv	Mõõt a mm	Pikkus mm	Pak. m	kaal kg/100 m	Toote nr
LKV D 25	kivihall	25	2000	36	9,500	6178 50 4

PVC Polüvinüülkloriid

€/m

Karbiku kaas asendamiseks.

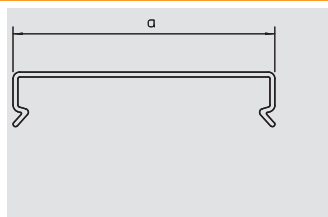

06 LFS\_Katalog\_2010\_Neuer\_Stand / et / 25/07/2011 (LLExport\_01305)

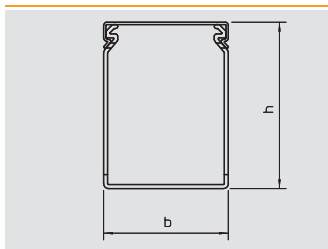

## Traadistuskarbik, tüüp 50037

Tüüp	värv	Pikkus mm	Mööde B x H mm	Pak. m	kaal kg/100 m	Toote nr
<b>LKV 50037</b>	kivihall	2000	37,5x50	48	44,500	<b>6178 31 2</b>

**PVC** Polüvinüülkloriid € / m

Traadistuskarbik põhjaperforatsiooni ja kaanega vastavalt standardile DIN EN 50085-2-3.

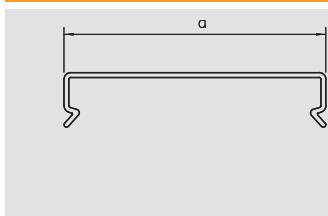

## Kaas

Tüüp	värv	Mööde a mm	Pikkus mm	Pak. m	kaal kg/100 m	Toote nr
<b>LKV D 37</b>	kivihall	37,5	2000	24	15,000	<b>6178 50 6</b>

**PVC** Polüvinüülkloriid € / m

Karbiku kaas asendamiseks.

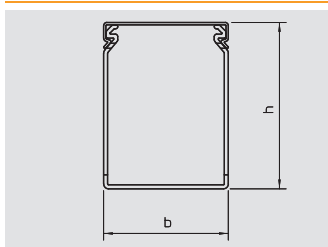

## Traadistuskarbik, tüüp 50050

Tüüp	värv	Pikkus mm	Mööde B x H mm	Pak. m	kaal kg/100 m	Toote nr
<b>LKV 50050</b>	kivihall	2000	50x50	36	50,000	<b>6178 31 4</b>

**PVC** Polüvinüülkloriid € / m

Traadistuskarbik põhjaperforatsiooni ja kaanega vastavalt standardile DIN EN 50085-2-3.

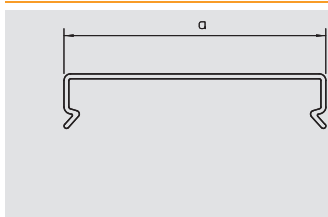

## Kaas

Tüüp	värv	Mööde a mm	Pikkus mm	Pak. m	kaal kg/100 m	Toote nr
<b>LKV D 50</b>	kivihall	50	2000	24	17,500	<b>6178 50 8</b>

**PVC** Polüvinüülkloriid € / m

Karbiku kaas asendamiseks.

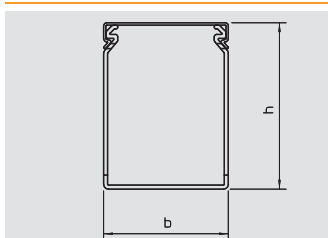

## Traadistuskarbik, tüüp 50075

Tüüp	värv	Pikkus mm	Mööde B x H mm	Pak. m	kaal kg/100 m	Toote nr
<b>LKV 50075</b>	kivihall	2000	75x50	24	66,000	<b>6178 31 6</b>

**PVC** Polüvinüülkloriid € / m

Traadistuskarbik põhjaperforatsiooni ja kaanega vastavalt standardile DIN EN 50085-2-3.

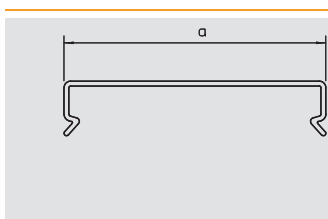

## Kaas

Tüüp	värv	Mööde a mm	Pikkus mm	Pak. m	kaal kg/100 m	Toote nr
<b>LKV D 75</b>	kivihall	75	2000	12	23,000	<b>6178 51 0</b>

**PVC** Polüvinüülkloriid € / m

Karbiku kaas asendamiseks.

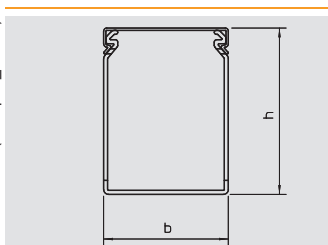

## Traadistuskarbik, tüüp 75025

Tüüp	värv	Pikkus mm	Mööde B x H mm	Pak. m	kaal kg/100 m	Toote nr
<b>LKV 75025</b>	kivihall	2000	25x75	40	48,500	<b>6178 32 0</b>

**PVC** Polüvinüülkloriid € / m

Traadistuskarbik põhjaperforatsiooni ja kaanega vastavalt standardile DIN EN 50085-2-3.

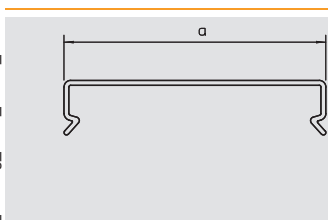

## Kaas

Tüüp	värv	Mööde a mm	Pikkus mm	Pak. m	kaal kg/100 m	Toote nr
<b>LKV D 25</b>	kivihall	25	2000	36	9,500	<b>6178 50 4</b>

**PVC** Polüvinüülkloriid € / m

Karbiku kaas asendamiseks.



# LKV DIN traadistuskarbiik

VK traadistuskarbiik, süsteem Dahl



## Traadistuskarbiik, tüüp 75037

Tüüp	värv	Pikkus mm	Mõõde B x H mm	Pak. m	kaal kg/100 m	Toote nr
LKV 75037	kivihall	2000	37,5x75	32	58,500	6178 32 2

PVC Polüvinüülkloriid

€/m

Traadistuskarbiik põhjaperforatsiooni ja kaanega vastavalt standardile DIN EN 50085-2-3.



## Kaas

Tüüp	värv	Mõõt a mm	Pikkus mm	Pak. m	kaal kg/100 m	Toote nr
LKV D 37	kivihall	37,5	2000	24	15,000	6178 50 6

PVC Polüvinüülkloriid

€/m

Karbiiku kaas asendamiseks.

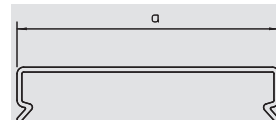

## Traadistuskarbiik, tüüp 75050

Tüüp	värv	Pikkus mm	Mõõde B x H mm	Pak. m	kaal kg/100 m	Toote nr
LKV 75050	kivihall	2000	50x75	24	67,500	6178 32 4

PVC Polüvinüülkloriid

€/m

Traadistuskarbiik põhjaperforatsiooni ja kaanega vastavalt standardile DIN EN 50085-2-3.

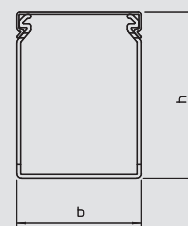

## Kaas

Tüüp	värv	Mõõt a mm	Pikkus mm	Pak. m	kaal kg/100 m	Toote nr
LKV D 50	kivihall	50	2000	24	17,500	6178 50 8

PVC Polüvinüülkloriid

€/m

Karbiiku kaas asendamiseks.

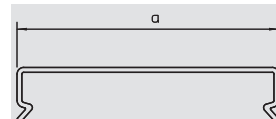

## Traadistuskarbiik, tüüp 75075

Tüüp	värv	Pikkus mm	Mõõde B x H mm	Pak. m	kaal kg/100 m	Toote nr
LKV 75075	kivihall	2000	75x75	16	80,000	6178 32 6

PVC Polüvinüülkloriid

€/m

Traadistuskarbiik põhjaperforatsiooni ja kaanega vastavalt standardile DIN EN 50085-2-3.

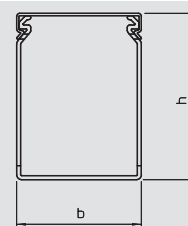

## Kaas

Tüüp	värv	Mõõt a mm	Pikkus mm	Pak. m	kaal kg/100 m	Toote nr
LKV D 75	kivihall	75	2000	12	23,000	6178 51 0

PVC Polüvinüülkloriid

€/m

Karbiiku kaas asendamiseks.

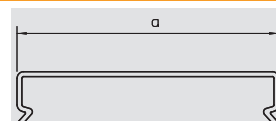

## Traadistuskarbiik, tüüp 75100

Tüüp	värv	Pikkus mm	Mõõde B x H mm	Pak. m	kaal kg/100 m	Toote nr
LKV 75100	kivihall	2000	100x75	16	105,500	6178 32 8

PVC Polüvinüülkloriid

€/m

Traadistuskarbiik põhjaperforatsiooni ja kaanega vastavalt standardile DIN EN 50085-2-3.

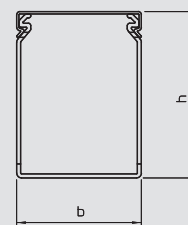

## Kaas

Tüüp	värv	Mõõt a mm	Pikkus mm	Pak. m	kaal kg/100 m	Toote nr
LKV D 100	kivihall	100	2000	12	34,500	6178 51 2

PVC Polüvinüülkloriid

€/m

Karbiiku kaas asendamiseks.

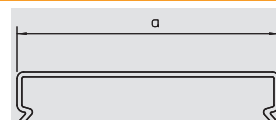

06 LFS\_Katalog\_2010\_Neuer\_Stand / et / 25/07/2011 (LLEXPOR\_01305)

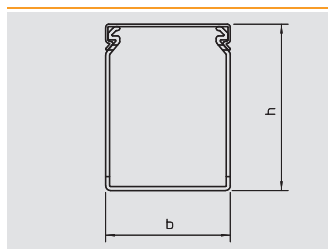

## Traadistuskarbiik, tüüp 75125

Tüüp	värv	Pikkus mm	Mööde B x H mm	Pak. m	kaal kg/100 m	Toote nr
<b>LKV 75125</b>	kivihall	2000	125x75	8	128,500	<b>6178 33 0</b>

**PVC** Polüvinüülkloriid €/m

Traadistuskarbiik põhjaperforatsiooni ja kaanega vastavalt standardile DIN EN 50085-2-3.

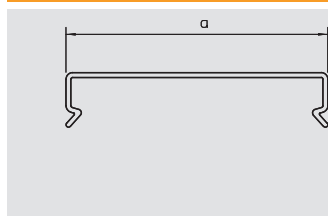
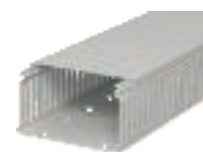

## Kaas

Tüüp	värv	Mööte a mm	Pikkus mm	Pak. m	kaal kg/100 m	Toote nr
<b>LKV D 125</b>	kivihall	125	2000	16	47,000	<b>6178 51 4</b>

**PVC** Polüvinüülkloriid €/m

Karbiiku kaas asendamiseks.

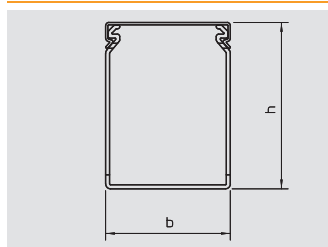

## Traadistuskarbiik, tüüp 10037

Tüüp	värv	Pikkus mm	Mööde B x H mm	Pak. m	kaal kg/100 m	Toote nr
<b>LKV 10037</b>	kivihall	2000	37,5x100	32	67,000	<b>6178 33 4</b>

**PVC** Polüvinüülkloriid €/m

Traadistuskarbiik põhjaperforatsiooni ja kaanega vastavalt standardile DIN EN 50085-2-3.

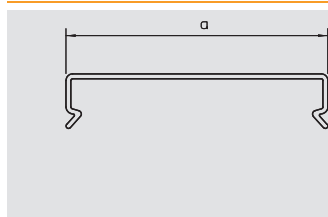

## Kaas

Tüüp	värv	Mööte a mm	Pikkus mm	Pak. m	kaal kg/100 m	Toote nr
<b>LKV D 37</b>	kivihall	37,5	2000	24	15,000	<b>6178 50 6</b>

**PVC** Polüvinüülkloriid €/m

Karbiiku kaas asendamiseks.

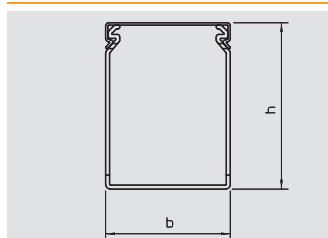

## Traadistuskarbiik, tüüp 10050

Tüüp	värv	Pikkus mm	Mööde B x H mm	Pak. m	kaal kg/100 m	Toote nr
<b>LKV 10050</b>	kivihall	2000	50x100	24	77,000	<b>6178 33 6</b>

**PVC** Polüvinüülkloriid €/m

Traadistuskarbiik põhjaperforatsiooni ja kaanega vastavalt standardile DIN EN 50085-2-3.

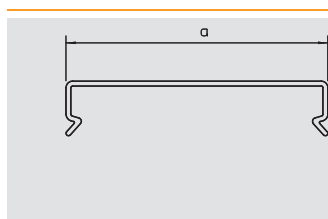

## Kaas

Tüüp	värv	Mööte a mm	Pikkus mm	Pak. m	kaal kg/100 m	Toote nr
<b>LKV D 50</b>	kivihall	50	2000	24	17,500	<b>6178 50 8</b>

**PVC** Polüvinüülkloriid €/m

Karbiiku kaas asendamiseks.

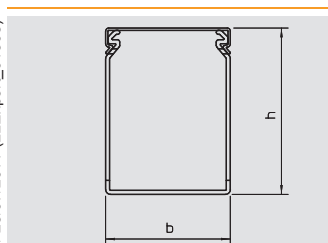

## Traadistuskarbiik, tüüp 10075

Tüüp	värv	Pikkus mm	Mööde B x H mm	Pak. m	kaal kg/100 m	Toote nr
<b>LKV 10075</b>	kivihall	2000	75x100	16	96,000	<b>6178 33 8</b>

**PVC** Polüvinüülkloriid €/m

Traadistuskarbiik põhjaperforatsiooni ja kaanega vastavalt standardile DIN EN 50085-2-3.

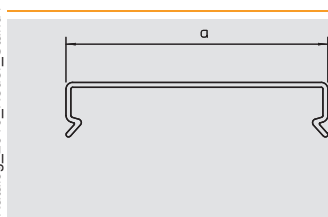

## Kaas

Tüüp	värv	Mööte a mm	Pikkus mm	Pak. m	kaal kg/100 m	Toote nr
<b>LKV D 75</b>	kivihall	75	2000	12	23,000	<b>6178 51 0</b>

**PVC** Polüvinüülkloriid €/m

Karbiiku kaas asendamiseks.



# LKV DIN traadistuskarbik



## Traadistuskarbik, tüüp 100100

Tüüp	värv	Pikkus mm	Mõõde B x H mm	Pak. m	kaal kg/100 m	Toote nr
<b>LKV 100100</b>	kivihall	2000	100x100	8	116,500	<b>6178 34 1</b>

**PVC** Polüvinüülkloriid € / m

Traadistuskarbik põhjaperforatsiooni ja kaanega vastavalt standardile DIN EN 50085-2-3.

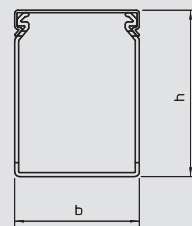

## Kaas

Tüüp	värv	Mõõt a mm	Pikkus mm	Pak. m	kaal kg/100 m	Toote nr
<b>LKV D 100</b>	kivihall	100	2000	12	34,500	<b>6178 51 2</b>

**PVC** Polüvinüülkloriid € / m

Karbiku kaas asendamiseks.

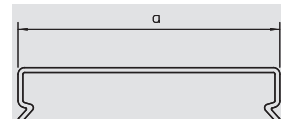

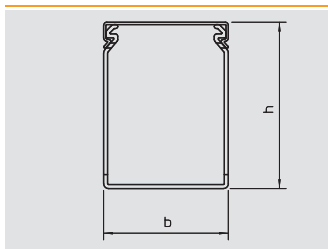

## Traadistuskarbiik, tüüp 75025

Tüüp	värv	Pikkus mm	Mõõde B x H mm	Pak. m	kaal kg/100 m	Toote nr
<b>LKV N 75025</b>	kivihall	2000	25x75	40	49,500	<b>6178 42 0</b>

**PVC** Polüvinüülkloriid €/m

Traadistuskarbiik põhjaperforatsiooni ja kaanega vastavalt standardile DIN EN 50085-2-3, reljeef küljepiludes juhtmete väljakukkumise takistamiseks.

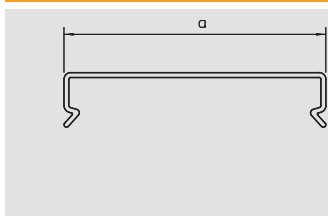

## Kaas

Tüüp	värv	Mõõt a mm	Pikkus mm	Pak. m	kaal kg/100 m	Toote nr
<b>LKV D 25</b>	kivihall	25	2000	36	9,500	<b>6178 50 4</b>

**PVC** Polüvinüülkloriid €/m

Karbiiku kaas asendamiseks.

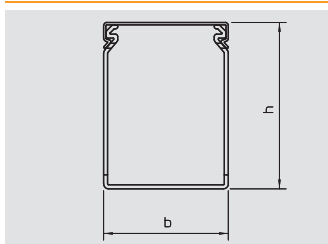

## Traadistuskarbiik, tüüp 75037

Tüüp	värv	Pikkus mm	Mõõde B x H mm	Pak. m	kaal kg/100 m	Toote nr
<b>LKV N 75037</b>	kivihall	2000	37,5x75	32	60,500	<b>6178 42 2</b>

**PVC** Polüvinüülkloriid €/m

Traadistuskarbiik põhjaperforatsiooni ja kaanega vastavalt standardile DIN EN 50085-2-3, reljeef küljepiludes juhtmete väljakukkumise takistamiseks.

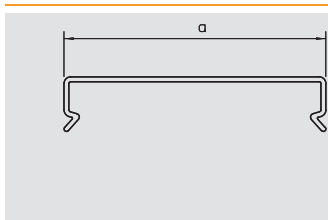

## Kaas

Tüüp	värv	Mõõt a mm	Pikkus mm	Pak. m	kaal kg/100 m	Toote nr
<b>LKV D 37</b>	kivihall	37,5	2000	24	15,000	<b>6178 50 6</b>

**PVC** Polüvinüülkloriid €/m

Karbiiku kaas asendamiseks.

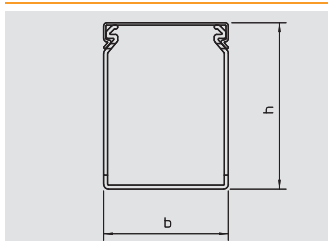

## Traadistuskarbiik, tüüp 75050

Tüüp	värv	Pikkus mm	Mõõde B x H mm	Pak. m	kaal kg/100 m	Toote nr
<b>LKV N 75050</b>	kivihall	2000	50x75	24	72,500	<b>6178 42 4</b>

**PVC** Polüvinüülkloriid €/m

Traadistuskarbiik põhjaperforatsiooni ja kaanega vastavalt standardile DIN EN 50085-2-3, reljeef küljepiludes juhtmete väljakukkumise takistamiseks.

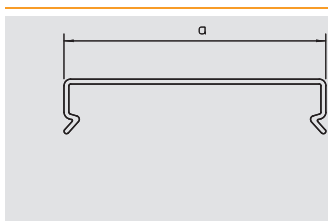

## Kaas

Tüüp	värv	Mõõt a mm	Pikkus mm	Pak. m	kaal kg/100 m	Toote nr
<b>LKV D 50</b>	kivihall	50	2000	24	17,500	<b>6178 50 8</b>

**PVC** Polüvinüülkloriid €/m

Karbiiku kaas asendamiseks.

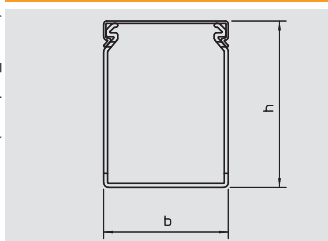

## Traadistuskarbiik, tüüp 75075

Tüüp	värv	Pikkus mm	Mõõde B x H mm	Pak. m	kaal kg/100 m	Toote nr
<b>LKV N 75075</b>	kivihall	2000	75x75	16	84,500	<b>6178 42 6</b>

**PVC** Polüvinüülkloriid €/m

Traadistuskarbiik põhjaperforatsiooni ja kaanega vastavalt standardile DIN EN 50085-2-3, reljeef küljepiludes juhtmete väljakukkumise takistamiseks.

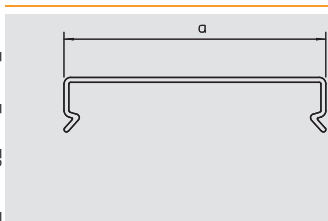

## Kaas

Tüüp	värv	Mõõt a mm	Pikkus mm	Pak. m	kaal kg/100 m	Toote nr
<b>LKV D 75</b>	kivihall	75	2000	12	23,000	<b>6178 51 0</b>

**PVC** Polüvinüülkloriid €/m

Karbiiku kaas asendamiseks.



# LKV DIN traadistuskarbiik

VK traadistuskarbiik, süsteem Dahl



## Traadistuskarbiik, tüüp 75100

Tüüp	värv	Pikkus mm	Mõõde B x H mm	Pak. m	kaal kg/100 m	Toote nr
<b>LKV N 75100</b>	kivihall	2000	100x75	16	112,000	<b>6178 42 8</b>

**PVC** Polüvinüülkloriid € / m

Traadistuskarbiik põhjaperforatsiooni ja kaanega vastavalt standardile DIN EN 50085-2-3, reljeef küljepiludes juhtmete väljakukkumise takistamiseks.

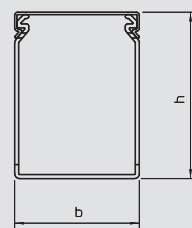

## Kaas

Tüüp	värv	Mõõt a mm	Pikkus mm	Pak. m	kaal kg/100 m	Toote nr
<b>LKV D 100</b>	kivihall	100	2000	12	34,500	<b>6178 51 2</b>

**PVC** Polüvinüülkloriid € / m

Karbiiku kaas asendamiseks.

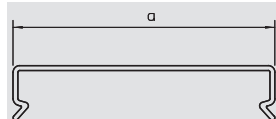

## Traadistuskarbiik, tüüp 75125

Tüüp	värv	Pikkus mm	Mõõde B x H mm	Pak. m	kaal kg/100 m	Toote nr
<b>LKV N 75125</b>	kivihall	2000	125x75	8	138,500	<b>6178 43 0</b>

**PVC** Polüvinüülkloriid € / m

Traadistuskarbiik põhjaperforatsiooni ja kaanega vastavalt standardile DIN EN 50085-2-3, reljeef küljepiludes juhtmete väljakukkumise takistamiseks.

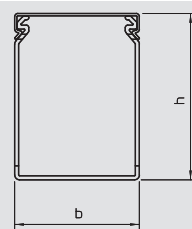

## Kaas

Tüüp	värv	Mõõt a mm	Pikkus mm	Pak. m	kaal kg/100 m	Toote nr
<b>LKV D 125</b>	kivihall	125	2000	16	47,000	<b>6178 51 4</b>

**PVC** Polüvinüülkloriid € / m

Karbiiku kaas asendamiseks.

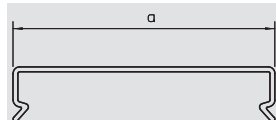

## Traadistuskarbiik, tüüp 10037

Tüüp	värv	Pikkus mm	Mõõde B x H mm	Pak. m	kaal kg/100 m	Toote nr
<b>LKV N 10037</b>	kivihall	2000	37,5x100	32	73,000	<b>6178 43 5</b>

**PVC** Polüvinüülkloriid € / m

Traadistuskarbiik põhjaperforatsiooni ja kaanega vastavalt standardile DIN EN 50085-2-3, reljeef küljepiludes juhtmete väljakukkumise takistamiseks.

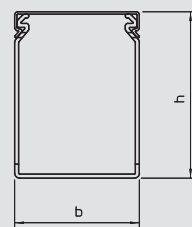

## Kaas

Tüüp	värv	Mõõt a mm	Pikkus mm	Pak. m	kaal kg/100 m	Toote nr
<b>LKV D 37</b>	kivihall	37,5	2000	24	15,000	<b>6178 50 6</b>

**PVC** Polüvinüülkloriid € / m

Karbiiku kaas asendamiseks.

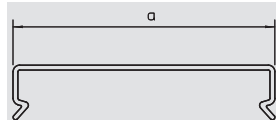

## Traadistuskarbiik, tüüp 10050

Tüüp	värv	Pikkus mm	Mõõde B x H mm	Pak. m	kaal kg/100 m	Toote nr
<b>LKV N 10050</b>	kivihall	2000	50x100	24	83,000	<b>6178 43 7</b>

**PVC** Polüvinüülkloriid € / m

Traadistuskarbiik põhjaperforatsiooni ja kaanega vastavalt standardile DIN EN 50085-2-3, reljeef küljepiludes juhtmete väljakukkumise takistamiseks.

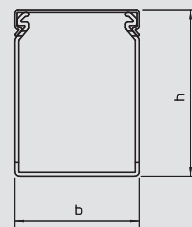

## Kaas

Tüüp	värv	Mõõt a mm	Pikkus mm	Pak. m	kaal kg/100 m	Toote nr
<b>LKV D 50</b>	kivihall	50	2000	24	17,500	<b>6178 50 8</b>

**PVC** Polüvinüülkloriid € / m

Karbiiku kaas asendamiseks.

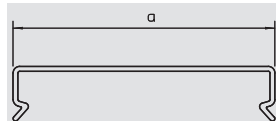

06 LFS\_Katalog\_2010\_Neuer\_Stand / et / 25/07/2011 (LLExport\_01306)

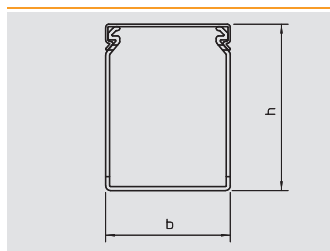

## Traadistuskarbiik, tüüp 10075

Tüüp	värv	Pikkus mm	Mööde B x H mm	Pak. m	kaal kg/100 m	Toote nr
<b>LKV N 10075</b>	kivihall	2000	75x100	16	102,000	<b>6178 43 9</b>

**PVC** Polüvinüülkloriid €/m

Traadistuskarbiik põhjaperforatsiooni ja kaanega vastavalt standardile DIN EN 50085-2-3, reljeef küljepiludes juhtmete väljakukkumise takistamiseks.

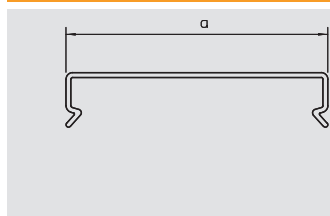

## Kaas

Tüüp	värv	Mööde a mm	Pikkus mm	Pak. m	kaal kg/100 m	Toote nr
<b>LKV D 75</b>	kivihall	75	2000	12	23,000	<b>6178 51 0</b>

**PVC** Polüvinüülkloriid €/m

Karbiiku kaas asendamiseks.

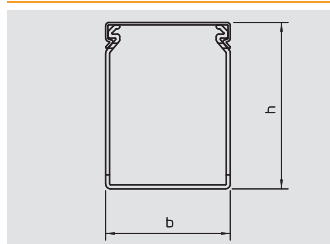

## Traadistuskarbiik, tüüp 100100

Tüüp	värv	Pikkus mm	Mööde B x H mm	Pak. m	kaal kg/100 m	Toote nr
<b>LKV N 100100</b>	kivihall	2000	100x100	8	122,500	<b>6178 44 1</b>

**PVC** Polüvinüülkloriid €/m

Traadistuskarbiik põhjaperforatsiooni ja kaanega vastavalt standardile DIN EN 50085-2-3, reljeef küljepiludes juhtmete väljakukkumise takistamiseks.

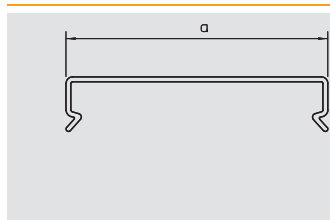

## Kaas

Tüüp	värv	Mööde a mm	Pikkus mm	Pak. m	kaal kg/100 m	Toote nr
<b>LKV D 100</b>	kivihall	100	2000	12	34,500	<b>6178 51 2</b>

**PVC** Polüvinüülkloriid €/m

Karbiiku kaas asendamiseks.



# LKV/H DIN traadistuskarbid, halogeenivaba

VK traadistuskarbid, süsteem Dahl



## Tradistuskarbid, tüüp 50037

Tüüp	värv	Pikkus mm	Mõõde B x H mm	Pak. m	kaal kg/100 m	Toote nr
<b>LKV H 50037</b>	helehall	2000	37,5x50	32	44,500	<b>6178 61 2</b>

PPO polüfenüleenoksiid €/m

Halogeenivaba traadistuskarbid põhjaperforatsiooni ja kaanega vastavalt standardile DIN EN 50085-2-3.

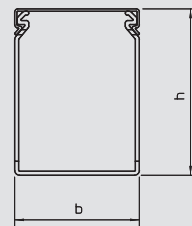

## Tradistuskarbid, tüüp 50050

Tüüp	värv	Pikkus mm	Mõõde B x H mm	Pak. m	kaal kg/100 m	Toote nr
<b>LKV H 50050</b>	helehall	2000	50x50	42	50,000	<b>6178 61 4</b>

PPO polüfenüleenoksiid €/m

Halogeenivaba traadistuskarbid põhjaperforatsiooni ja kaanega vastavalt standardile DIN EN 50085-2-3.

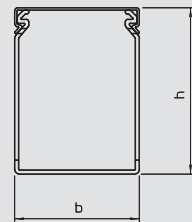

## Tradistuskarbid, tüüp 50075

Tüüp	värv	Pikkus mm	Mõõde B x H mm	Pak. m	kaal kg/100 m	Toote nr
<b>LKV H 50075</b>	helehall	2000	75x50	28	65,000	<b>6178 61 6</b>

PPO polüfenüleenoksiid €/m

Halogeenivaba traadistuskarbid põhjaperforatsiooni ja kaanega vastavalt standardile DIN EN 50085-2-3.

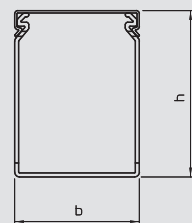

## Tradistuskarbid, tüüp 75037

Tüüp	värv	Pikkus mm	Mõõde B x H mm	Pak. m	kaal kg/100 m	Toote nr
<b>LKV H 75037</b>	helehall	2000	37,5x75	24	45,000	<b>6178 62 2</b>

PPO polüfenüleenoksiid €/m

Halogeenivaba traadistuskarbid põhjaperforatsiooni ja kaanega vastavalt standardile DIN EN 50085-2-3.

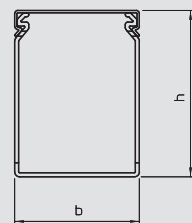

## Tradistuskarbid, tüüp 75050

Tüüp	värv	Pikkus mm	Mõõde B x H mm	Pak. m	kaal kg/100 m	Toote nr
<b>LKV H 75050</b>	helehall	2000	50x75	28	65,000	<b>6178 62 4</b>

PPO polüfenüleenoksiid €/m

Halogeenivaba traadistuskarbid põhjaperforatsiooni ja kaanega vastavalt standardile DIN EN 50085-2-3.

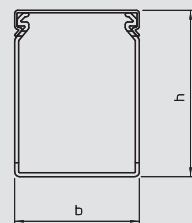

## Tradistuskarbid, tüüp 75075

Tüüp	värv	Pikkus mm	Mõõde B x H mm	Pak. m	kaal kg/100 m	Toote nr
<b>LKV H 75075</b>	helehall	2000	75x75	24	80,000	<b>6178 62 6</b>

PPO polüfenüleenoksiid €/m

Halogeenivaba traadistuskarbid põhjaperforatsiooni ja kaanega vastavalt standardile DIN EN 50085-2-3.

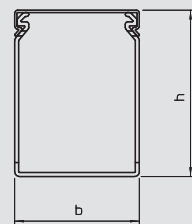

## Tradistuskarbid, tüüp 75100

Tüüp	värv	Pikkus mm	Mõõde B x H mm	Pak. m	kaal kg/100 m	Toote nr
<b>LKV H 75100</b>	helehall	2000	100x75	16	105,000	<b>6178 62 8</b>

PPO polüfenüleenoksiid €/m

Halogeenivaba traadistuskarbid põhjaperforatsiooni ja kaanega vastavalt standardile DIN EN 50085-2-3.

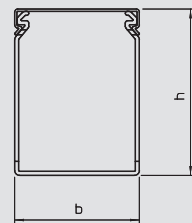

06 LFS\_Katalog\_2010\_Neuer\_Stand / et / 25/07/2011 (LLEExport\_01306)

# LKV/H DIN traadistuskarvik, halogeenivaba

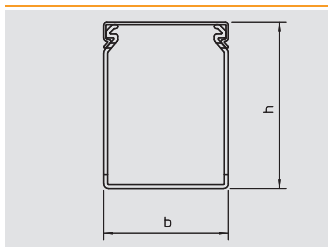

## Traadistuskarvik, tüüp 75125

Tüüp	värv	Pikkus mm	Mõõde B x H mm	Pak. m	kaal kg/100 m	Toote nr
<b>LKV H 75125</b>	helehall	2000	125x75	16	130,000	<b>6178 63 0</b>

PPO polüfenüleenoksiid € / m

Halogeenivaba traadistuskarvik põhjaperforatsiooni ja kaanega vastavalt standardile DIN EN 50085-2-3.



VK traadistuskarvik, süsteem Dahl



# VK traadistuskarbiku tarvikud

VK traadistuskarbik, süsteem Dahl



## Juhtmehoidja traadistuskarbikutele LK4 ja LK4/N

Tüüp	värv	Mõõt a mm	Mõõt b mm	Pak. tükk	kaal kg/100 Tk	Toote nr
LK4 H	kivihall	56	20	100	0,470	<b>6178 09 2</b>

**PS** polüstüreen €/100 Tk

Traadistuskarbikute LK4 ja LK4/N juhtmehoidja. Juhtmehoidja takistab juba paigaldatud juhtmete väljakukkumist. Eelmärgitud murdekohtade abil saab karbiku laiust vähendada suurustele 38, 28 ja 23 mm.

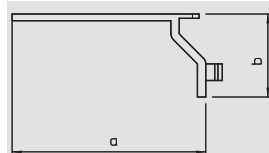

## Juhtmehoidja traadistuskarbikutele LKV ja LKV/N

Tüüp	värv	Mõõt a mm	Mõõt b mm	Pak. tükk	kaal kg/100 Tk	Toote nr
LKV H	kivihall	56	20	100	0,470	<b>6178 34 9</b>

**PS** polüstüreen €/100 Tk

Traadistuskarbikute LKV ja LKV/N juhtmehoidja. Juhtmehoidja takistab juba paigaldatud juhtmete väljakukkumist. Eelmärgitud murdekohtade abil saab karbiku laiust vähendada suurustele 38, 28 ja 23 mm.

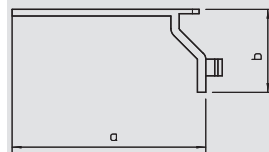

## Juhtmehoidja traadistuskarbikutele LKV/H

Tüüp	värv	Mõõt a mm	Mõõt b mm	Pak. tükk	kaal kg/100 Tk	Toote nr
LKV H H	helehall	56	20	100	0,361	<b>6178 65 0</b>

**PS** polüstüreen €/100 Tk

Halogeenivabade traadistuskarbikute LKV/H juhtmehoidja. Juhtmehoidja takistab juba paigaldatud juhtmete väljakukkumist. Eelmärgitud murdekohtade abil saab karbiku laiust vähendada suurustele 38, 28 ja 23 mm.

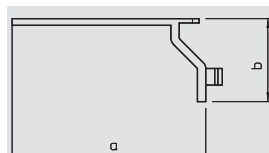

## Tööriist plastfiksaatori paigaldamiseks

Tüüp	Mõõt a mm	värv	Pak. tükk	kaal kg/100 Tk	Toote nr
KNW1	150	must	1	9,300	<b>6178 52 7</b>
KNW2	150	must	1	9,300	<b>6178 52 9</b>

**POM** Polüütsetaal €/tk

4,5 mm ankurneetide paigaldamise seade.

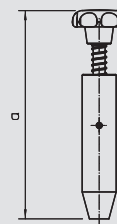

## Laienev neet, KSN 1

Tüüp	värv	Mõõt a mm	Pak. tükk	kaal kg/100 Tk	Toote nr
KSN1	helehall	4,5	100	0,024	<b>6178 52 0</b>

**PP** polüpropüleen €/100 Tk

VK traadistuskarbik kinnitatakse neetimiseseadme ja ankurneedi abil lülituskapi montaažiplaadile.



## Laienev neet, KSN 2

Tüüp	värv	Mõõt a mm	Pak. tükk	kaal kg/100 Tk	Toote nr
KSN2	helehall	6	100	0,056	<b>6178 52 2</b>

**PP** polüpropüleen €/100 Tk

VK traadistuskarbik kinnitatakse neetimiseseadme ja ankurneedi abil lülituskapi montaažiplaadile.



## Lõiketangid

Tüüp	Pak. tükk	kaal kg/100 Tk	Toote nr
AKZ	1	30,857	<b>6178 53 5</b>

**St** teras €/tk

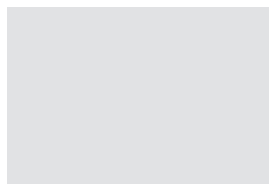

06 LFS\_Katalog\_2010\_Neuer\_Stand / et / 25/07/2011 (LLEExport\_01306)

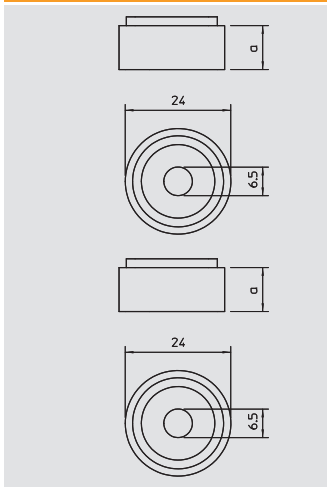

## Distantsihoidja

Tüüp	värv	Mõõt a	Läbimõõt	Pak. tükk	kaal kg/100 Tk	Toote nr
AH1	hall	12	24	100	0,354	6178 54 0

PVC Polüvinüülkloriid €/100 Tk

Järjestikku kasutatav distantsdetail kõrguseerinevuste tasandamiseks erinevate kõrgustega detailide vahel.

Tüüp	värv	Mõõt a	Läbimõõt	Pak. tükk	kaal kg/100 Tk	Toote nr
AH2	hall	20	24	100	0,576	6178 54 2

PVC Polüvinüülkloriid €/100 Tk

Kõrguseerinevuste tasandamiseks erinevate kõrgustega detailide vahel.

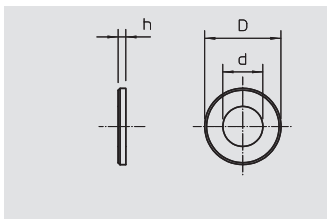

## Alusseib

Tüüp	värv	Mõõt h	Läbimõõt	Pak. tükk	kaal kg/100 Tk	Toote nr
ULS	hall	3	5	100	0,166	6178 54 8

PVC Polüvinüülkloriid €/100 Tk

Alusseib kõrguseerinevuste tasandamiseks.

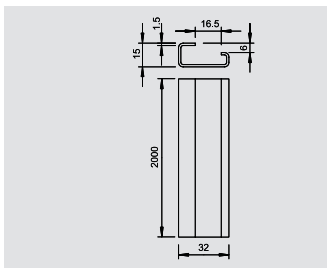

## Kandesiin, perforeerimata

Tüüp	Mudel	Materjali-paksus	Pikkus	liit	kaal	Toote nr
		mm	mm	m	kg/100 m	
2064 GTP 2M	perforeerimata	1,5	2000	20	70,000	1115 05 7

St teras GTP galvaaniliselt tsingitud, läbipaistvaks passiveeritud €/100 m

G-siin G32 vastavalt standardile DIN EN 60715 (varem DIN EN 50035).

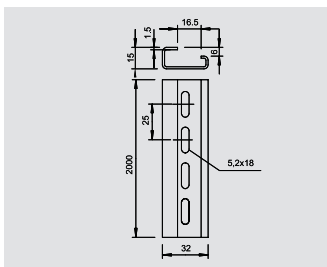

## Kandesiin, perforeeritud

Tüüp	Mudel	Materjali-paksus	Pikkus	liit	kaal	Toote nr
		mm	mm	m	kg/100 m	
2064 GTP 2M	perforeeritud	1,5	2000	20	69,000	1115 06 5

St teras GTP galvaaniliselt tsingitud, läbipaistvaks passiveeritud €/100 m

G-siin G32 vastavalt standardile DIN EN 60715 (varem DIN EN 50035).

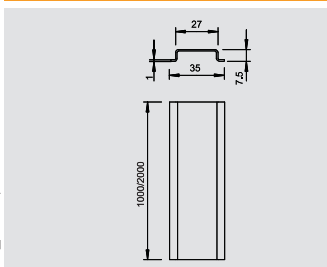

## Kübarprofiilsiin, perforeerimata

Tüüp	Mudel	Materjali-paksus	Pikkus	liit	kaal	Toote nr
		mm	mm	m	kg/100 m	
2069 2M GTP	perforeerimata	1	2000	50	34,000	1115 65 0

St teras GTP galvaaniliselt tsingitud, läbipaistvaks passiveeritud €/100 m

DIN-latt 35 x 7,5 mm vastavalt standardile DIN EN 60715 (varem DIN EN 50022).

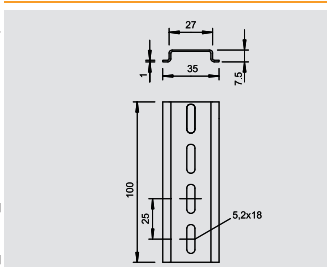

## Kübarprofiilsiin, perforeeritud

Tüüp	Mudel	Materjali-paksus	Pikkus	liit	kaal	Toote nr
		mm	mm	m	kg/100 m	
2069 2M GTP	perforeeritud	1	2000	50	33,000	1115 66 9



St teras GTP galvaaniliselt tsingitud, läbipaistvaks passiveeritud €/100 m

DIN-latt 35 x 7,5 mm vastavalt standardile DIN EN 60715 (varem DIN EN 50022).





## Registrid

	Tähestikuline sisukord	362
	Numbriline loend	366
	Tüübiloend	374



# Alfabētiskais saturs rādītājs

## A

Adaptera stabilizators, paredz. ISST70140, 321  
Adaptera stabilizators, paredz. ISST70140B, 323  
Adapteris, paredzēts par 90° pagriezta slēdža iebūvēšanai, 348  
Aizsargrāmis, paredz. ISSHS4, 334  
Aizsargv. pieslēguma leņķis, 226, 231, 237, 242, 248, 253, 259, 265  
Alumīnija vāks, sliede 50, 293  
Alumīnija vāks, sliede 80, 292, 295  
Alumīnija vāks, sliede 50, 296  
Antenu kontaktligzda - SAT 1/2 moduļa platums, 348  
Antenu kontaktligzda, 1/1 moduļa platums, 349

## Ā

Ārējā stūra likuma rādiuss, 189, 192, 195, 202, 206  
Ārējā stūra pārsegs, 130-134, 158, 160  
Ārējā stūra profila vāks, alumīnija, sliede 50, 293, 296  
Ārējā stūra profila vāks, alumīnija, sliede 80, 293, 296  
Ārējā stūra profils, kanāla dziļums 70 mm, 224, 256  
Ārējā stūra profils, kanāla dziļums 90 mm, 224, 256  
Ārējā stūra vāks, alumīnijs, 269, 272, 275, 278, 281, 284, 287, 290, 299, 302  
Ārējā stūra vāks, plastmasa, gluds, 211, 214, 217, 224, 229, 234, 240, 245, 256, 262  
Ārējā stūra vāks, plastmasa, rievots., 211, 214, 217, 224, 229, 234, 240, 262  
Ārējā stūra vāks, plastmasa, teknes veida, 245, 256  
Ārējā stūra vāks, tērauda loksne, 224, 229, 234, 240, 245, 256, 262  
Ārējā stūra vāks, tērauda loksne, sliede 50, 251  
Ārējā stūra vāks, tērauda loksne, sliede 80, 251  
Ārējais stūris, 86, 88, 91, 93, 95, 97, 99-100, 102-115, 117-120, 129, 141, 143, 145, 147, 149, 151, 153, 189, 192, 195, 202, 206, 211, 214, 217, 269, 272, 275, 278, 281, 284, 287, 290, 293, 296, 299, 302  
Ārējais stūris, kanāla dziļums 70 mm, 229, 234, 240, 245, 250, 262  
Ārējais stūris, kanāla dziļums 90 mm, 229, 234, 240, 245, 251, 262  
Ārējais stūris, regulējams., 189, 192, 195, 202, 206

## A

Atdaloša traversa, 212, 215, 218  
Atslēga pieslēguma un savienojuma aizsardzības sistēmai, 352  
Augšējā daļa, 126, 164-181, 191  
Augšējā daļa CEE ierīces kontaktligzdai, 125  
Augšējā daļa divvietīgai ierīču kārbai, kanāla augstums 110 mm, 123  
Augšējā daļa divvietīgai ierīču kārbai, kanāla augstums 130 mm, 123  
Augšējā daļa divvietīgai ierīču kārbai, kanāla augstums 150 mm, 123  
Augšējā daļa divvietīgai ierīču kārbai, kanāla augstums 170 mm, 124  
Augšējā daļa divvietīgai ierīču kārbai, kanāla augstums 210 mm, 124  
Augšējā daļa trīsvietīgai ierīču kārbai, kanāla augstums 110 mm, 123  
Augšējā daļa trīsvietīgai ierīču kārbai, kanāla augstums 130 mm, 123  
Augšējā daļa trīsvietīgai ierīču kārbai, kanāla augstums 150 mm, 124  
Augšējā daļa trīsvietīgai ierīču kārbai, kanāla augstums 170 mm, 124  
Augšējā daļa vienvietīgai ierīču kārbai, kanāla augstums 110 mm, 122  
Augšējā daļa vienvietīgai ierīču kārbai, kanāla augstums 130 mm, 123  
Augšējā daļa vienvietīgai ierīču kārbai, kanāla augstums 150 mm, 123  
Augšējā daļa vienvietīgai ierīču kārbai, kanāla augstums 170 mm, 124  
Augšējās daļas skava, 126, 188, 191  
Augšējās daļas skavas kanālam ar platumu 110 mm, 121  
Augšējās daļas skavas kanālam ar platumu 130 mm, 121  
Augšējās daļas skavas kanālam ar platumu 150 mm, 121  
Augšējās daļas skavas kanālam ar platumu 170 mm, 121  
Augšējās daļas skavas kanālam ar platumu 210 mm, 121  
Augšējās daļas skavas kanālam ar platumu 230 mm, 122  
Augšējās daļas skavas kanālam ar platumu 60 mm, 121  
Augšējās daļas skavas kanālam ar platumu 90 mm, 121  
Augšupvērsts plakans leņķa profils, kanāla dziļums 70 mm, 234, 245, 251, 256, 262  
Augšupvērsts plakans leņķa profils, kanāla dziļums 90 mm, 234, 245, 251, 256, 262

## B

Balsta pamatne classic, skārda grīdas plāksnēm, 333

## C

CEE ierīču kārba, 124  
CEE pārejas atloks 16 A, 124  
CEE pārejas atloks 32 A, 125  
CP tīkla vads, izpildījums spraudnis - ligzda, 352-353

## D

Datu pārsūtīšanas tehnikas kronšteins, 1/1 moduļa platums, 351  
Datu pārsūtīšanas tehnikas kronšteins, 1/2 moduļa platums, 351  
Datu pārsūtīšanas tehnikas kronšteins, tips A, 1/1 moduļa platums, 353  
Datu pārsūtīšanas tehnikas kronšteins, tips B, 1/1 moduļa platums, 353  
Datu pārsūtīšanas tehnikas kronšteins, tips C, 1/1 moduļa platums, 354  
Datu pārsūtīšanas tehnikas kronšteins, tips EP, 1/1 moduļa, 354 platums  
Datu pārsūtīšanas tehnikas kronšteins, tips F, 1/1 moduļa platums, 354  
Datu pārsūtīšanas tehnikas kronšteins, tips PA, 1/1 moduļa, 355 platums  
Datu pieslēguma modulis ar nesošo plāksni, kat. 5, 350  
Datu pieslēguma modulis ar nesošo plāksni, kat. 5e, ekranēts, 350  
Datu pieslēguma modulis ar nesošo plāksni, kat. 6, 350  
Datu pieslēguma modulis ar nesošo plāksni, kat. 6, ekranēts., 350 paredzēts 10GbE  
Drošības klipsis, 351  
Dubultais slēdzis, 1/1 moduļa platums, 347

## F

Fiksēšanas skava, 223, 228, 233, 239, 244, 250, 255, 261

## G

Gala elements, 87, 89-90, 92, 94-96, 98-99, 101-114, 116-120, 126, 128-134, 141, 144-145, 147, 149, 151, 153, 195, 212, 215, 218, 270, 273, 276, 279, 282, 285, 288, 291, 294, 297, 300, 303  
Gala elements kreisajā pusē, 158, 160, 190, 193, 202, 206  
Gala elements labajā pusē, 158, 160, 190, 193, 203, 207  
Gala elements, kanāla dziļums 70 mm, 226, 231, 236, 242, 247, 252, 258, 264  
Gala elements, kanāla dziļums 90 mm, 226, 231, 236, 242, 247, 253, 258, 264  
Galvenā plate Aura sērijai, tainstūra veida ar standarta, 356  
caurejamību  
Grīdas kanāls, tips 2650, 161  
Grīdas konsole, 309  
Grīdas plāksne, paredz. ISS110100F, 330  
Grīdas plāksne, paredz. ISS140100F, 332  
Grīdas plāksne, paredz. ISS140110, 326  
Grīdas plāksne, paredz. ISS70110, 324  
Grīdas plāksne, paredz. ISS90110, 325  
Grīdas plāksne, paredz. ISS070140, 322  
Grīdas plāksne, paredz. ISSRM45F, 328  
Grīdas plāksne, paredz. ISST70140, 321  
Grīdas plāksne, paredz. ISST70140B, 323  
Griestu vāks, 324  
Griestu vāks, paredz. ISS 120, 320  
Griestu vāks, paredz. ISS 140110, 326  
Griestu vāks, paredz. ISS 140220, 327  
Griestu vāks, paredz. ISS110100F, 330  
Griestu vāks, paredz. ISS110100R, 329  
Griestu vāks, paredz. ISS140100F, 332  
Griestu vāks, paredz. ISS140100R, 331  
Griestu vāks, paredz. ISS90110, 325  
Griestu vāks, paredz. ISS070140, 322  
Griestu vāks, paredz. ISSRM45, 328  
Griestu vāks, paredz. ISSRM45F, 329  
Griestu vāks, paredz. ISST70140, 322  
Griestu vāks, paredz. ISST70140B, 324  
Gumijas paliktnis, paredz. ISS 140110, 326  
Gumijas paliktnis, paredz. ISS70110, 324  
Gumijas paliktnis, paredz. ISS90110, 325  
Gumijas paliktnis, paredz. ISS070140, 322  
Gumijas paliktnis, paredz. ISSRM45, 328  
Gumijas paliktnis, paredz. ISSRM45F, 329  
Gumijas paliktnis, paredz. ISST70140, 321  
Gumijas paliktnis, paredz. ISST70140B, 323

Iebūvējama vienība, 358  
 ledzenams dibelis, 125  
 lekšējā stūra līkuma rādiuss, 189  
 lekšējā stūra līkuma rādiuss., 192, 195, 201, 205  
 lekšējā stūra profils, kanāla dziļums 90 mm, 230  
 lekšējā stūra skrūve, 130-134, 158, 160  
 lekšējais stūra profils, 141, 143, 145, 147, 149, 151, 153  
 lekšējais stūris, 86, 88, 91, 93, 95, 97, 99-100, 102-115, 117-120, 129, 189, 192, 194-195, 201, 205, 212, 215, 218, 269, 272, 275, 278, 281, 284, 287, 290, 294, 297, 299, 302  
 lekšējais stūris, kanāla dziļums 70 mm, 225, 230, 235, 241  
 lekšējais stūris, kanāla dziļums 90 mm, 225, 235, 241  
 lekšējais stūris., 205  
 lerīces kontaktlīgzda, 122  
 lerīces statīvs, 159, 161  
 lerīču montāžas kanāls Rapid 45, tips GEK-A 53100, 200  
 lerīču montāžas kanāls Rapid 45, tips GEK-A 53160, 204  
 lerīču montāžas kanāls Rapid 45, tips GEK-K 53100, 188  
 lerīču montāžas kanāls Rapid 45, tips GEK-K 53160, 191  
 lerīču montāžas kanāls Rapid 45, tips GEK-K 53160-3, 194  
 lerīču montāžas kanāls, kanāla dziļums 70 mm, 222, 227, 232, 238, 243, 249, 254, 260  
 lerīču montāžas kanāls, kanāla dziļums 90 mm, 222, 227, 232, 238, 243, 249, 254, 260  
 lerīču montāžas kanāls, tips GEK-A 100213, 301  
 lerīču montāžas kanāls, tips GEK-A 70110, 268  
 lerīču montāžas kanāls, tips GEK-A 70133, 274  
 lerīču montāžas kanāls, tips GEK-A 70213, 298  
 lerīču montāžas kanāls, tips GEK-A 90110, 271  
 lerīču montāžas kanāls, tips GEK-A 90133, 277  
 lerīču montāžas kanāls, tips GEK-AA 70173, 280  
 lerīču montāžas kanāls, tips GEK-AA 70173D, 292  
 lerīču montāžas kanāls, tips GEK-AA 70213, 286  
 lerīču montāžas kanāls, tips GEK-AA 90173, 283  
 lerīču montāžas kanāls, tips GEK-AA 90173D, 295  
 lerīču montāžas kanāls, tips GEK-AA 90213, 289  
 lerīču montāžas kanāls, tips GK70110, 210  
 lerīču montāžas kanāls, tips GK70130, 213  
 lerīču montāžas kanāls, tips GK70170, 216  
 lerīču montāžas kārba CEE ar kontaktlīgzdu CEE 16 A, 358  
 lerīču montāžas kārba CEE ar kontaktlīgzdu CEE 32 A, 358  
 lerīču montāžas kārba, divvietīga, 210, 213, 216, 222, 227, 232, 238, 243, 249, 254, 260, 268, 271, 274, 277, 280, 283, 286, 289, 292, 295, 298, 301, 333, 337  
 lerīču montāžas kārba, divvietīga/trisvietīga, Modul 45, 340  
 lerīču montāžas kārba, trisvietīga, Modul 45, 333, 337  
 lerīču montāžas kārba, vienvietīga, 210, 213, 216, 222, 227, 232, 238, 243, 249, 254, 260, 268, 271, 274, 277, 280, 283, 286, 289, 292, 295, 298, 301, 333, 337  
 lerīču montāžas kārba, vienvietīga, Modul 45, 333, 337, 340  
 lespraužams aizsargs, paredzēts RJ45, 352  
 levades kanāls, 315  
 levilkšanas instruments, 333  
 Instalācijas kolonna, tips ISS110100F, 330  
 Instalācijas kolonna, tips ISS110100R, 329  
 Instalācijas kolonna, tips ISS140100F, 331  
 Instalācijas kolonna, tips ISS140100R, 331  
 Instalācijas kolonna, tips ISS140110, 326  
 Instalācijas kolonna, tips ISS140220, 327  
 Instalācijas kolonna, tips ISS70110, 324  
 Instalācijas kolonna, tips ISS90110, 325  
 Instalācijas kolonna, tips ISSHS2D120, 336  
 Instalācijas kolonna, tips ISSO70140, 322  
 Instalācijas kolonna, tips ISSRHSM45, 336  
 Instalācijas kolonna, tips ISSRM45, 327  
 Instalācijas kolonna, tips ISSRM45F, 328  
 Instalācijas kolonna, tips ISST70140, 321  
 Instalācijas vadu kanāls, tips 100100, 178, 181  
 Instalācijas vadu kanāls, tips 10037, 177, 180  
 Instalācijas vadu kanāls, tips 10050, 177, 180  
 Instalācijas vadu kanāls, tips 10075, 177, 181

Instalācijas vadu kanāls, tips 25025, 174  
 Instalācijas vadu kanāls, tips 37025, 174  
 Instalācijas vadu kanāls, tips 37037, 174  
 Instalācijas vadu kanāls, tips 50025, 174  
 Instalācijas vadu kanāls, tips 50037, 175, 182  
 Instalācijas vadu kanāls, tips 50050, 175, 182  
 Instalācijas vadu kanāls, tips 50075, 175, 182  
 Instalācijas vadu kanāls, tips 75025, 175, 179  
 Instalācijas vadu kanāls, tips 75037, 176, 179, 182  
 Instalācijas vadu kanāls, tips 75050, 176, 179, 182  
 Instalācijas vadu kanāls, tips 75075, 176, 179, 182  
 Instalācijas vadu kanāls, tips 75100, 176, 180, 182  
 Instalācijas vadu kanāls, tips 75125, 177, 180, 183  
 Instalācijas vadu kanāls, tips LK4 15015, 164  
 Instalācijas vadu kanāls, tips LK4 30015, 164  
 Instalācijas vadu kanāls, tips LK4 30025, 164  
 Instalācijas vadu kanāls, tips LK4 40025, 164  
 Instalācijas vadu kanāls, tips LK4 40040, 165  
 Instalācijas vadu kanāls, tips LK4 40060, 165  
 Instalācijas vadu kanāls, tips LK4 40080, 165  
 Instalācijas vadu kanāls, tips LK4 40100, 165  
 Instalācijas vadu kanāls, tips LK4 60015, 166  
 Instalācijas vadu kanāls, tips LK4 60025, 166  
 Instalācijas vadu kanāls, tips LK4 60040, 166  
 Instalācijas vadu kanāls, tips LK4 60060, 166  
 Instalācijas vadu kanāls, tips LK4 60080, 167  
 Instalācijas vadu kanāls, tips LK4 60100, 167  
 Instalācijas vadu kanāls, tips LK4 60120, 167  
 Instalācijas vadu kanāls, tips LK4 80025, 167  
 Instalācijas vadu kanāls, tips LK4 80040, 168  
 Instalācijas vadu kanāls, tips LK4 80060, 168  
 Instalācijas vadu kanāls, tips LK4 80080, 168  
 Instalācijas vadu kanāls, tips LK4 80100, 168  
 Instalācijas vadu kanāls, tips LK4 80120, 169  
 Instalācijas vadu kanāls, tips LK4/N 60015, 170  
 Instalācijas vadu kanāls, tips LK4/N 60025, 170  
 Instalācijas vadu kanāls, tips LK4/N 60040, 170  
 Instalācijas vadu kanāls, tips LK4/N 60060, 170  
 Instalācijas vadu kanāls, tips LK4/N 60080, 171  
 Instalācijas vadu kanāls, tips LK4/N 60100, 171  
 Instalācijas vadu kanāls, tips LK4/N 60120, 171  
 Instalācijas vadu kanāls, tips LK4/N 80025, 171  
 Instalācijas vadu kanāls, tips LK4/N 80040, 172  
 Instalācijas vadu kanāls, tips LK4/N 80060, 172  
 Instalācijas vadu kanāls, tips LK4/N 80080, 172  
 Instalācijas vadu kanāls, tips LK4/N 80100, 172  
 Instalācijas vadu kanāls, tips LK4/N 80120, 173

## K

Kabeļa izvads, 1/1 moduļa platums, 349  
 Kabeļu nostiepes fiksators, 210, 213, 216, 223, 228, 233, 239, 244, 250, 255, 261, 268, 271, 274, 277, 280, 283, 286, 289, 292, 295, 298, 301, 340, 344, 346  
 Kanāla augšējā daļa, plastmasas, gluda, 255, 261  
 Kanāla augšējā daļa, plastmasas, teknes veida, 233, 255, 261  
 Kanāla augšējā daļa, tērauda loksnes, 255, 261  
 Kanāla skavas, 155, 212, 215, 218, 226, 231, 236, 242, 247, 253, 258, 264  
 Kanāla skavas funkciju nodrošināšanai E30 - E90, 148  
 Kanāla vāks, 188, 194  
 Kanāla vāks, gluds, 210, 213, 216  
 Kanāla vāks, plastmasas, gluds, 223, 228, 233, 239, 244  
 Kanāla vāks, rievots, 211, 214, 217, 223, 228, 239, 244  
 Kanāla vāks, tērauda loksnes, 223, 228, 233, 239, 244  
 Kanāla vāks, tērauda loksnes, sliede 50, 250  
 Kanāla vāks, tērauda loksnes, sliede 80, 250  
 Kanāla vāks., 200  
 Kanāls, tips LKM 20020, 138  
 Kanāls, tips LKM 20030, 139  
 Kanāls, tips LKM 30030, 140

## K

Kanāls, tips LKM 40040, 141  
Kanāls, tips LKM 40060, 143  
Kanāls, tips LKM 60060, 145  
Kanāls, tips LKM 60100, 147  
Kanāls, tips LKM 60150, 149  
Kanāls, tips LKM 60200, 151  
Kanāls, tips LKM 80080, 153  
Kanāls, tips WDK 100130, 118  
Kanāls, tips WDK 10020, 86  
Kanāls, tips WDK 100230, 120  
Kanāls, tips WDK 10030, 88  
Kanāls, tips WDK 15015, 90  
Kanāls, tips WDK 15030, 91  
Kanāls, tips WDK 15040, 93  
Kanāls, tips WDK 20020, 95  
Kanāls, tips WDK 20035, 96  
Kanāls, tips WDK 20050, 97  
Kanāls, tips WDK 25025, 99  
Kanāls, tips WDK 25040, 100  
Kanāls, tips WDK 30030, 102  
Kanāls, tips WDK 30045, 103  
Kanāls, tips WDK 40040, 104  
Kanāls, tips WDK 40060, 105  
Kanāls, tips WDK 40090, 106  
Kanāls, tips WDK 40110, 107  
Kanāls, tips WDK 60060, 108  
Kanāls, tips WDK 60090, 109  
Kanāls, tips WDK 60110, 111  
Kanāls, tips WDK 60130, 112  
Kanāls, tips WDK 60150, 113  
Kanāls, tips WDK 60170, 114  
Kanāls, tips WDK 60210, 115  
Kanāls, tips WDK 60230, 110  
Kanāls, tips WDK 80170, 119  
Kanāls, tips WDK 80210, 117  
Kanāls, tips WDK-H 20020, 128  
Kanāls, tips WDK-H 30045, 129  
Kanāls, tips WDK-H 40060, 130  
Kanāls, tips WDK-H 40061, 131  
Kanāls, tips WDK-H 60090, 132  
Kanāls, tips WDK-H 60110, 133  
Kanāls, tips WDK-H 60150, 134  
Kanāls, tips WDK-N 10020, 86  
Kanāls, tips WDK-N 10030, 88  
Kanāls, tips WDK-N 15030, 91  
Kanāls, tips WDK-N 15040, 93  
Kanāls, tips WDK-N 20050, 97  
Kanāls, tips WDK-N 25040, 100  
Knaibles, 184  
Kodējošā tapa, 344  
Komutācijas kabelis, izpildījums spraudnis - spraudnis, 352  
Kontaktligzda ar zemējuma kontaktu 0° – kodēts izpildījums, 343  
Kontaktligzda ar zemējuma kontaktu 33°, 341  
Kontaktligzda ar zemējuma kontaktu 33° – kodēts izpildījums, 343-344  
Kontaktligzda ar zemējuma kontaktu 0°, 340-341  
Kontaktligzda ar zemējuma kontaktu, 0°, 341-342  
Kontaktligzda ar zemējuma kontaktu, 33°, 342  
Kontaktligzda, Dānijas standarts, 0°, 344  
Kontaktligzda, Šveices standarts, 0°, 344  
Kontaktligzdas bloks ar pamatni piezīmēm, divvietīgs, 357  
Kontaktligzdas bloks ar pamatni piezīmēm, trīsvietīgs, 358  
Kontaktligzdas bloks ar pamatni piezīmēm, vienvietīgs, 357  
Kontaktligzdas bloks, divvietīgs, 357  
Kontaktligzdas bloks, trīsvietīgs, 357  
Kontaktligzdas bloks, vienvietīgs, 357  
Konvekcijas režģa profils, 309  
Konvektora apšuvums, 309  
Krustojums, 190, 193, 202, 206  
Krustslēdzis, 1/1 moduļa platums, 347

## L

Lejupvērsts plakans leņķa profils, 188, 191, 201, 205, 269, 272, 275, 278, 281, 284, 287, 290, 293, 296, 299, 302  
Lejupvērsts plakans leņķa profils, kanāla dziļums 70 mm, 235, 246, 251, 257, 263  
Lejupvērsts plakans leņķa profils, kanāla dziļums 90 mm, 235, 246, 251, 257, 263  
Līmspīles, 307  
Lokanās caurules savienojums, paredz. ISS110100F, 330  
Lokanās caurules savienojums, paredz. ISS140100F, 332  
Lokanās caurules savienojums, paredz. ISSRM45F, 328

## M

Malu drošības gredzens, 138-140, 142, 144, 146, 148, 150, 152, 154  
Mehāniskis un vizuāls iespraužams aizsargs, 351  
Minikanāls ar limplēvi un šarnīra augšdaļu, MD12, 84  
Minikanāls ar limplēvi un šarnīra augšdaļu, MD17, 85  
Minikanāls ar limplēvi un šarnīra augšdaļu, MD4, 84  
Minikanāls ar limplēvi un šarnīra augšdaļu, MD7, 84  
Minikanāls ar limplēvi, M11, 84  
Minikanāls ar limplēvi, M7, 84  
Minikanāls ar limplēvi, M9, 84  
Modul 45connect kontaktligzda ar zemējuma kontaktu 33°, 345  
divvietīga  
Modul 45connect kontaktligzda ar zemējuma kontaktu 33°, 345  
trīsvietīga  
Modul 45connect kontaktligzdas 33°, divvietīgas, 345  
Modul 45connect kontaktligzdas 33°, trīsvietīgas, 345  
Montāžas balstenis datu pārsūtīšanai un Modul 45-connect, 340  
Montāžas balsts, tērauda loksne, ar augšējo daļu PVC, 318  
Montāžas balsts, tērauda loksne, ar tērauda loksnes augšējo daļu, 318  
Montāžas balsts, tips ISS120, 320  
Montāžas balsts, tips ISSHS140250, 335  
Montāžas balsts, tips ISSHS140500, 335  
Montāžas balsts, tips ISSHS140700, 335  
Montāžas balsts, tips ISSHS4, 334  
Montāžas balsts, tips ISSHS6, 336  
Montāžas balsts, tips ISSHSO270140, 335  
Montāžas balsts, tips ISSHSO70140, 335  
Montāžas balsts, tips ISST70140B, 323  
Montāžas un savienojuma profils konvekcijas režģiem, kanāla, 307  
dziļums 70 mm  
Montāžas un savienojuma profils konvekcijas režģiem, kanāla, 307  
dziļums 90 mm  
Montāžas un savienojuma profils konvektora apšuvumam, kanāla, 308  
dziļums 70 mm  
Montāžas un savienojuma profils konvektora apšuvumam, kanāla, 309  
dziļums 90 mm

## N

Nesošā sliede, bez perforējuma, 185  
Nesošā sliede, perforēta, 185  
Nosedzošais panelis, 318  
Nosedzošais rāmis S990 ar pamatni piezīmēm, divvietīgs, 355  
Nosedzošais rāmis S990 ar pamatni piezīmēm, divvietīgs, 356  
taisnstūra veida  
Nosedzošais rāmis S990 ar pamatni piezīmēm, trīsvietīgs, 356  
Nosedzošais rāmis S990 ar pamatni piezīmēm, trīsvietīgs, 356  
taisnstūra veida  
Nosedzošais rāmis S990, divvietīgs, 355  
Nosedzošais rāmis S990, trīsvietīgs, 355  
Nosedzošais rāmis sērijai Aura, taisnstūra veida, 356  
Nosedzošais rāmis S990 ar pamatni piezīmēm, vienvietīgs, 355  
Nosedzošais rāmis S990 ar pamatni piezīmēm, vienvietīgs, 356  
taisnstūra veida  
Nosedzošais rāmis S990, vienvietīgs, 355  
Nosedzošais rāmis sērijai Aura, 356  
Noslēgts vāks, 1/1 moduļa platums, 350  
Noslēgts vāks, 1/2 moduļa platums, 350

## O

Optiskā kabeļa savienojums ar nesošo plāksni, 350

**P**

Pamatnes statīvs, 308  
 Pārsega profils, paredz. ISS 120, 320  
 Pārslēdzis, 1/1 moduļa platums, 346-347  
 Pārslēdzis, 1/2 moduļa platums, 346-347  
 Pārsprieguma aizsardzības modulis, akustisks signāls, 348  
 Pārsprieguma aizsargierīce, 1/2 moduļa platums, akustisks signāls, 348  
 Pārsprieguma aizsargierīce, 1/2 moduļa platums, optisks signāls, 348  
 Perforators, 196  
 Pieslēguma adapteris, taisns, ligzda, 346  
 Pieslēguma adapteris, taisns, spraudnis, 345  
 Pieslēguma adapteris, U formas, spraudnis, 346  
 Pieslēguma un savienojuma aizsardzība, 352  
 Plakanā leņķa profila augšējā daļa, alumīnijs, sliede 50, 294  
 Plakanā leņķa profila augšējā daļa, alumīnijs, sliede 80, 294  
 Plakanā leņķa profila augšējā daļa, sliede 50, 252  
 Plakanā leņķa profila līkuma rādiuss, 189, 192, 194, 201, 205  
 Plakanā leņķa profila vāks, 129-134  
 Plakanā leņķa profila vāks, alumīnijs, sliede 50, 297  
 Plakanā leņķa profila vāks, alumīnijs, sliede 80, 297  
 Plakanā leņķa vāks, alumīnijs, 269, 272, 275, 278, 281, 284, 287, 290, 299, 302  
 Plakanā leņķa vāks, plastmasa, gluda, 225, 235, 241, 246, 257, 263  
 Plakanā leņķa vāks, plastmasa, gluds., 211, 214, 217, 230  
 Plakanā leņķa vāks, plastmasa, rienvots., 212, 215, 218, 225, 230, 235, 241, 246, 263  
 Plakanā leņķa vāks, plastmasa, teknes veida, 257  
 Plakanā leņķa vāks, tērauda loksne, 225, 230, 235, 241, 246, 257, 263  
 Plakanā leņķa vāks, tērauda loksne, sliede 80, 252  
 Plakans leņķa profils, 141, 143, 145, 147, 149, 151, 153, 194, 211, 214, 217  
 Plakans leņķa profils, augšupvērsts, 188, 191, 201, 205, 269, 272, 275, 278, 281, 284, 287, 290, 293, 296, 299, 302  
 Plakans leņķa profils, kanāla dziļums 70 mm, 224, 229, 240  
 Plakans leņķa profils, kanāla dziļums 90 mm, 224, 230, 240  
 Plastmasas kniežu instruments, 184  
 Potenciālu izlīdzināšanas kontaktligzda, 1/1 moduļa platums, 349  
 Priekšējais pārsegs, 126  
 Profilu savienotājs, horizontāls, 307  
 Profilu savienotājs, vertikāls, 308

**S**

Salaiduma vietu pārsegums, 86, 88, 91, 93, 97, 100, 158, 160, 188, 191, 194, 201, 205  
 Salaiduma vietu pārsegums, kanāla dziļums 70 mm, 223, 228, 233, 239, 244, 250, 255, 261  
 Salaiduma vietu pārsegums, kanāla dziļums 90 mm, 223, 229, 233, 239, 244, 250, 255, 261  
 Salaiduma vietu savienotājs, 138-141, 143, 145, 147, 149, 151, 153, 200, 204  
 Samazināšanas ietvars no RJ45 uz RJ11/RJ12, 351

**Š**

Šarnīra putekļu sargs, 351

**S**

Savienojuma adapteris, 346  
 Savienojuma profils kanālam ar augstumu 170 mm, 306  
 Savienojuma profils kanālam ar augstumu 210 mm, 306  
 Savienojums, 210, 213, 216, 268, 271, 274, 277, 280, 283, 286, 289, 292, 295, 298, 301  
 Savienojums, kanāla dziļums 70 mm, 222, 227, 232, 238, 243, 249, 254, 260  
 Savienojums, kanāla dziļums 90 mm, 222, 227, 232, 238, 243, 249, 254, 260  
 Savilcējtapas, 309  
 Sienas gala pārsegs, alumīnijs, atvērts, 70110, 312  
 Sienas gala pārsegs, alumīnijs, atvērts, 70130, 312  
 Sienas gala pārsegs, alumīnijs, atvērts, 70170, 313  
 Sienas gala pārsegs, alumīnijs, atvērts, 70210, 313  
 Sienas gala pārsegs, alumīnijs, atvērts, 90110, 312  
 Sienas gala pārsegs, alumīnijs, atvērts, 90130, 313  
 Sienas gala pārsegs, alumīnijs, atvērts, 90170, 313  
 Sienas gala pārsegs, alumīnijs, atvērts, 90210, 313  
 Sienas gala pārsegs, alumīnijs, slēgts, 70110, 313  
 Sienas gala pārsegs, alumīnijs, slēgts, 70130, 314

**S**

Sienas gala pārsegs, alumīnijs, slēgts, 70170, 314  
 Sienas gala pārsegs, alumīnijs, slēgts, 70210, 314  
 Sienas gala pārsegs, alumīnijs, slēgts, 90110, 314  
 Sienas gala pārsegs, alumīnijs, slēgts, 90130, 314  
 Sienas gala pārsegs, alumīnijs, slēgts, 90170, 314  
 Sienas gala pārsegs, alumīnijs, slēgts, 90210, 315  
 Sienas gala pārsegs, PVC, atvērts, 70110, 309  
 Sienas gala pārsegs, PVC, atvērts, 70130, 310  
 Sienas gala pārsegs, PVC, atvērts, 70170, 310  
 Sienas gala pārsegs, PVC, atvērts, 70210, 310  
 Sienas gala pārsegs, PVC, atvērts, 90110, 310  
 Sienas gala pārsegs, PVC, atvērts, 90130, 310  
 Sienas gala pārsegs, PVC, atvērts, 90170, 310  
 Sienas gala pārsegs, PVC, atvērts, 90210, 311  
 Sienas gala pārsegs, PVC, slēgts, 70110, 311  
 Sienas gala pārsegs, PVC, slēgts, 70130, 311  
 Sienas gala pārsegs, PVC, slēgts, 70170, 311  
 Sienas gala pārsegs, PVC, slēgts, 70210, 312  
 Sienas gala pārsegs, PVC, slēgts, 90110, 311  
 Sienas gala pārsegs, PVC, slēgts, 90130, 311  
 Sienas gala pārsegs, PVC, slēgts, 90170, 312  
 Sienas gala pārsegs, PVC, slēgts, 90210, 312  
 Sienas konsoles adapteris, paredz. GK, kanāla augstums 110 mm, 306  
 Sienas konsoles adapteris, paredz. GK, kanāla augstums 130 mm, 306  
 Sienas konsoles adapteris, paredz. GK, kanāla augstums 170 mm, 306  
 Skaņas aizsargbarjera, 315  
 Skaņas aizsargbarjera, metros mērāmi izstrādājumi, 315

**Š**

Šķēres WDK kanāliem, slīps griezumus, 85  
 Šķēres WDK kanāliem, taisns griezumus, 85

**S**

SKL grīdlistu kanāls, tips SKL 50 D, 158  
 SKL grīdlistu kanāls, tips SKL 70 D, 160  
 Slēdzis, 1/1 moduļa platums, 347  
 Slēdzis, 1/2 moduļa platums, 346  
 Spaiļu stiprinājums, 319  
 Spraišļa kniede, KSN 1, 184  
 Spraišļa kniede, KSN 2, 184  
 Starpliķa, 185  
 Starpliķa skārda grīdas plāksnei, 333  
 Starpsiena, 155, 188, 191, 194, 200, 204  
 Starpsiena kanālam ar augstumu 100 mm, 122  
 Starpsiena kanālam ar augstumu 40 mm, 122  
 Starpsiena kanālam ar augstumu 60 mm, 122  
 Starpsiena kanālam ar augstumu 80 mm, 122  
 Starpsiena, paredz. ISS 120, 320  
 Stiprinājuma konsoles, 306  
 Stiprinājuma leņķis, paredz. ISST70140, 321  
 Stiprinājuma leņķis, paredz. ISST70140B, 323

**T**

T un krustveida detaļu vāks, 112-113, 129-134  
 T veida un krustveida savienojums, 104  
 T veida detaļa, 141, 143, 145, 147, 149, 151, 153, 195, 212, 215, 218, 270, 273, 276, 279, 282, 285, 288, 291, 294, 297, 300, 303  
 T veida detaļa, augšupvērsta, 190, 193, 202, 206  
 T veida detaļa, kanāla dziļums 70 mm, 225, 230, 236, 241, 247, 252, 258, 264  
 T veida detaļa, kanāla dziļums 90 mm, 226, 231, 236, 241, 247, 252, 258, 264  
 T veida detaļa, lejupvērsta, 190, 193, 202, 206  
 T veida savienojums, 86, 88, 92, 94-95, 97, 99, 101-103  
 T veida un krustveida detaļu vāks, 114-115, 117-120  
 T veida un krustveida savienojums, 105-111  
 Taisnā leņķa pagrieziens, 88, 91, 93, 95, 97, 99-100, 102-115, 117-120  
 Taisnā leņķa pagrieziens, 86  
 Tālrūpa pieslēguma kārba, 1/1 moduļa platums, 349  
 Tērauda loksnes starpsiena, kanāla dziļums 70 mm, 226, 231, 236, 242, 247, 253, 258, 264

## Alfabētiskais saturs rādītājs

### T

Tērauda loksnes starpsiena, kanāla dziļums 90 mm, 226, 231, 236, 242, 247,  
253, 258, 264

### U

U profila sliede, bez perforējuma, 185  
U profila sliede, perforēta, 185

### V

Vadu turētājs, 143, 155  
Vadu turētājs, paredz. tipam LK4 un LK4/N, 184  
Vadu turētājs, paredz. tipam LKV un LKV/N, 184  
Vadu turētājs, paredz. tipam LKV/H, 184  
Vāks, 204  
Vāks, alumīnija, 268, 271, 274, 277, 280, 283, 286, 289, 298, 301  
Vienkāršots iekšējā stūra profils, kanāla dziļums 70 mm, 246, 252, 257, 263  
Vienkāršots iekšējā stūra profils, kanāla dziļums 90 mm, 246, 252, 257, 263

### Ž

Žalūziju slēdzis, 1/1 moduļa platums, 347  
Žalūziju taustiņslēdzis, 1/1 moduļa platums, 347

### Z

Zemējuma spaiļes, 200, 204  
Zemējuma vads, 200, 204

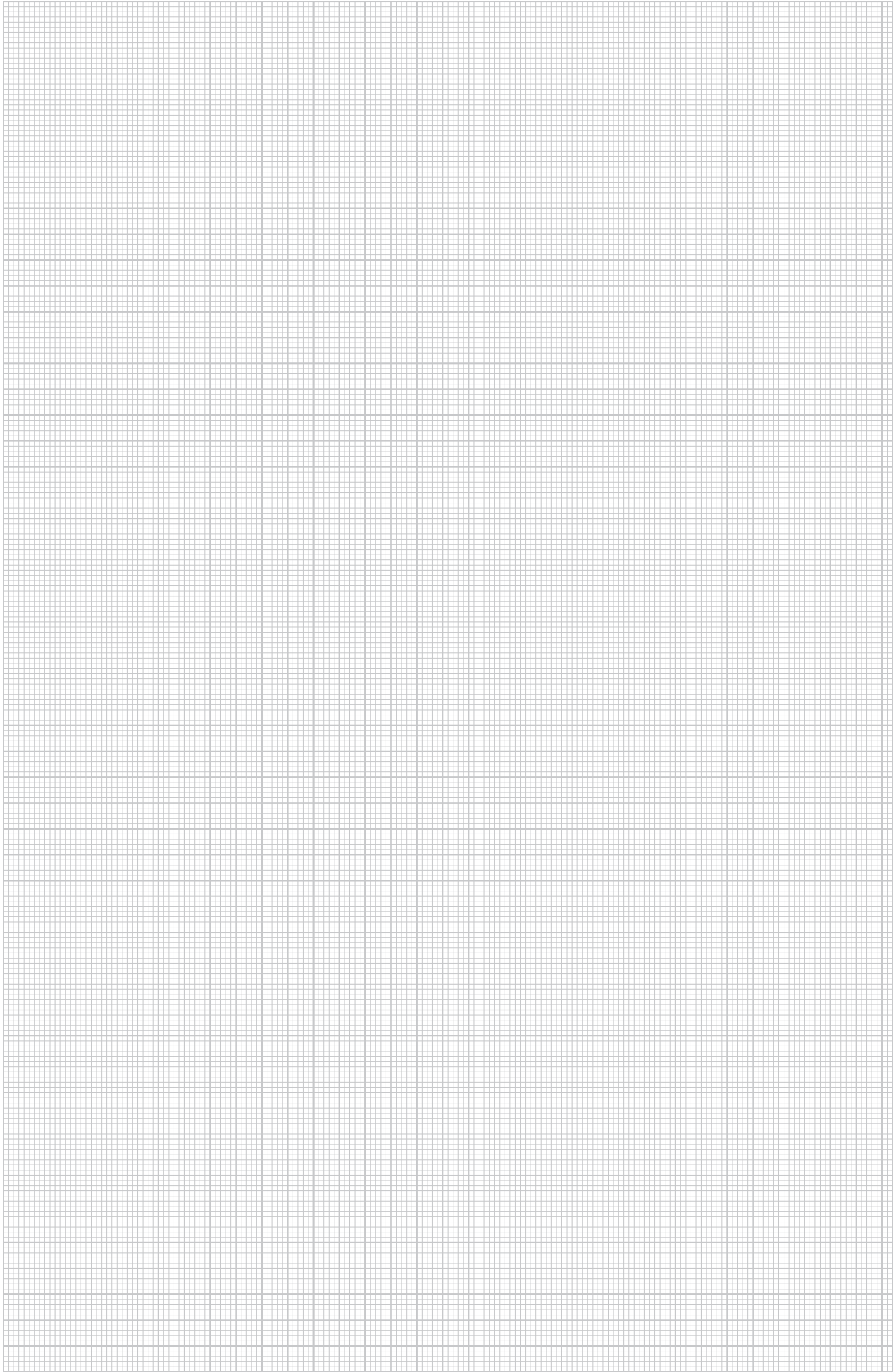

# Numeratīvs saturs rādītājs

EAN numura uzbūve: valsts kods **40**

ražotāja kods **1219** (art. numuriem, kas sākas ar **0: 1010**)

individuālais EAN-C **5647589**

EAN-C.	Art.-Nr.	Cena	Lapa	EAN-C.	Art.-Nr.	Cena	Lapa	EAN-C.	Art.-Nr.	Cena	Lapa	EAN-C.	Art.-Nr.	Cena	Lapa				
5044291	1115 05 7	€/100 m	185	6024070	6023 04 5	€/gab.	112	6667512	6026 40 0	€/m	99	5273417	6107 27 2	€/gab.	356				
5044352	1115 06 5		185	6024193	6023 06 1		114	6030255	6026 41 9		99	5273424	6107 27 8		356				
5045434	1115 65 0		185	6192618	6023 08 1		189	6030316	6026 42 7		99	5273462	6107 37 2		356				
5045496	1115 66 9		185	6192670	6023 08 5		189	6030439	6026 44 3		100	5273479	6107 37 8		356				
			6192731	6023 08 9		189	6030491	6026 45 1				100							
5669197	2351 05 6	€/100	125	6024315	6023 09 6	€/m	122	6332953	6026 81 8	€/m	102	6292578	6116 02 7	€/m	188				
				6024377	6023 11 8			122	6333011		6026 82 6		102		6292516	6116 05 1		191	
5080886	5092 45 1	€/gab.	348	6024438	6023 12 6	€/gab.	115	6640874	6026 85 0	€/m	103	5391630	6116 07 3	€/gab.	194				
				6024551	6023 14 2			106	6640935		6026 86 9		103		6708970	6116 10 8		188	
				6024919	6023 20 7			122	6030675		6026 98 2		122		6176236	6116 11 6		188	
				6025039	6023 22 3			108	6030736		6026 99 0		122		6441259	6116 15 0		188	
6362530	6020 80 1	€/m	161	6025459	6023 31 2	€/100	105			€/m	105	6183739	6116 15 4	€/m	201				
				6025572	6023 33 9			107	6667697		6027 01 6		104		5391647	6116 16 3		194	
6016273	6020 88 7	€/gab.	105	6026111	6023 50 9	€/100	121	6667819	6027 03 2	€/m	105	5391913	6116 16 7	€/m	190				
6016334	6020 89 5			106	6026173		6023 51 7		121		6667871	6027 04 0			106	5391920	6116 16 9		202
6016396	6020 90 9			107	6026234		6023 52 5		121		6667994	6027 10 5			107	5391968	6116 17 2		193
					6637874		6023 53 3		121		6668052	6027 11 3			108	5391975	6116 17 4		206
6016877	6021 01 8	€/gab.	106	6026296	6023 54 1	€/100	121	6668113	6027 12 1	€/m	109	5391982	6116 18 0	€/m	190				
6016990	6021 03 4			107	6026357		6023 57 6		121		6668175	6027 14 8			111	5392026	6116 18 1		202
					6639250		6023 58 4		122		6668236	6027 15 6			112	5392033	6116 18 4		193
				106					122		6668298	6027 16 4			113	5392040	6116 18 5		206
6017171	6021 09 3	€/gab.	106			€/gab.		6668298	6027 16 4	€/m	114	5391654	6116 19 3	€/m	195				
6017652	6021 19 0			106					6668359		6027 17 2		115		5428688	6116 20 1		194	
6018253	6021 33 6			106	6027132		6024 00 9		124		6668410	6027 18 0			110	5391661	6116 20 3		195
6018857	6021 49 2			105	6027255		6024 02 5		124		6668472	6027 22 9			119	6709038	6116 20 5		189
6018918	6021 50 6	€/m	106	6027316	6024 03 3	€/100	125	6668533	6027 23 7	€/m	117	6183678	6116 21 0	€/m	201				
6018970	6021 51 4			107	6638116		6024 43 2		113		6668595	6027 24 5			118	6192793	6116 21 3		189
6019212	6021 69 7			105	6639496		6024 44 0		110		6668656	6027 25 3			120	6440955	6116 22 1		192
6019274	6021 70 0			107	6027491		6024 46 7		119							6184699	6116 22 6		205
6019335	6021 71 9	€/m	105	6027552	6024 47 5	€/100	117	6669257	6028 15 2	€/m	126	6192977	6116 24 8	€/m	192				
6019397	6021 72 7			107	6027613		6024 48 3		118		6773893	6028 18 7			126	5428695	6116 26 1		195
6019458	6021 73 5			105	6025097		6024 50 5		120							5391678	6116 26 3		195
6019519	6021 74 3			107	6638291		6024 52 1		113		6628216	6028 40 3			85	6441013	6116 26 4		189
6019816	6021 84 0	€/m	111	6027675	6024 56 4	€/100	110	6628278	6028 41 1	€/m	85	6184033	6116 26 9	€/m	202				
6019878	6021 85 9			112	6027736		6024 57 2		119							6192915	6116 27 2		189
6019939	6021 86 7			114	6027798		6024 58 0		117							6616879	6116 28 0		192
6019991	6021 87 5			115	6638475		6024 59 9		118		5364139	6106 67 1			343	6184811	6116 28 5		206
6637577	6021 88 3	€/gab.	113	6639854	6024 60 2	€/100	113	5364146	6106 67 3	€/m	343	6193158	6116 29 4	€/m	192				
6638956	6021 89 1			110	6027859		6024 61 0		110		5364177	6106 67 5			343	6441075	6116 30 2		190
6020119	6021 91 3			109	6027910		6024 62 9		119		5364184	6106 67 7			343	6184095	6116 30 7		202
6020171	6021 94 8			108	6027972		6024 63 7		117		5364191	6106 67 9			343	6441136	6116 32 9		193
6020232	6022 00 6	€/gab.	109	6501311	6024 65 3	€/100	118	5364207	6106 68 1	€/m	343	6184873	6116 33 4	€/m	206				
6020294	6022 01 4			109	6501915		6024 68 8		120		5364238	6106 68 3			343	6616930	6116 35 3		190
6020355	6022 02 2			111	6501670		6024 71 8		120		5364245	6106 68 5			343	6184217	6116 35 8		203
6637515	6022 03 0			112	6638659		6024 76 9		113		5364252	6106 68 7			343	6441198	6116 38 8		193
6020416	6022 04 9	€/m	113	6640034	6024 77 7	€/100	110	5364269	6106 68 9	€/m	343	6184934	6116 39 3	€/m	207				
6638895	6022 05 7			113	6028030		6024 79 3		113		5364306	6106 69 1			343	5391685	6116 40 3		195
6020478	6022 06 5			114	6028030		6024 79 3		119		5364313	6106 69 3			343	6184330	6116 41 8		188
				110	6028092		6024 80 7		117		5364320	6106 69 5			343	6184996	6116 43 4		191
6020539	6022 07 3	€/gab.	115	6028153	6024 81 5	€/100	118	5364368	6106 69 7	€/m	343	6184514	6116 46 4	€/m	188				
6020713	6022 11 1			108	6637935		6024 82 3		113		5364375	6106 69 9			343	6191239	6116 48 0		191
6020836	6022 14 6			109	6639311		6024 83 1		110		5364382	6106 70 1			343	5391692	6116 49 3		194
6020959	6022 16 2			111	6028214		6024 85 8		119		5364412	6106 70 3			343	5391883	6116 49 5		190
6021079	6022 18 9	€/m	112	6028276	6024 87 4	€/100	117	5364429	6106 70 5	€/m	343	5391890	6116 49 6	€/m	202				
6021130	6022 19 7			114	6028337		6024 88 2		118		5364436	6106 70 7			343	5392088	6116 49 8		193
6021253	6022 21 9			115	6651375		6024 90 4		120		5364443	6106 70 9			343	5392095	6116 49 9		206
6021376	6022 23 5			109							5364474	6106 71 1			343				
6021499	6022 25 1	€/gab.	111	6667338	6024 94 7	€/m	90	5364481	6106 71 3	€/m	343	6198252	6116 51 5	€/m	200				
6021611	6022 28 6			112	6642250		6024 95 5		90		5364498	6106 71 5			343	6204199	6116 53 6		204
6021673	6022 29 4			114	6642311		6024 96 3		90		5364504	6106 71 7			343	6202034	6116 55 8		200
6021796	6022 31 6			115							5364535	6106 71 9			343				
6021918	6022 33 2	€/m	109	6332779	6025 00 5	€/100	91	5364542	6106 72 1	€/m	344	6210015	6116 57 9	€/m	201				
6022038	6022 35 9			109	6332830		6025 01 3		91		5364559	6106 72 3			344	6210138	6116 59 5		205
6022151	6022 37 5			111	6667390		6025 10 2		95		5364566	6106 72 5			344	6210251	6116 61 7		202
6022212	6022 38 3			112	6028399		6025 11 0		95		5364597	6106 72 7			344	6210558	6116 64 7		206
6022274	6022 39 1	€/m	114	6028511	6025 13 7	€/100	93	5364603	6106 72 9	€/m	344	6210671	6116 66 8	€/m	201				
6022519	6022 44 8			108	6028573		6025 15 3		95		5364610	6106 73 5			344	6210978	6116 68 5		205
6022694	6022 49 9			115	6028634		6025 16 1		93							6211272	6116 70 9		201
6022755	6022 50 2			108	6028870		6025 41 2		104		5120957	6107 00 2			355	6211395	6116 73 6		205
6022816	6022 52 9	€/m	108	602899															

## Numeratīvs satura rādītājs

EAN-C.	Art.-Nr.	Cena	Lapa	EAN-C.	Art.-Nr.	Cena	Lapa	EAN-C.	Art.-Nr.	Cena	Lapa	EAN-C.	Art.-Nr.	Cena	Lapa
		€/gab.				€/gab.				€/gab.				€/m	
6645077	6117 02 5		341	5006886	6117 31 6		351	5402466	6117 96 0		352	6507979	6150 51 9		91
6458950	6117 02 7		341					5402473	6117 96 2		352	6493456	6150 52 7		91
6597376	6117 02 9		341	5701200	6117 31 8		351	5402480	6117 96 4		352	6097999	6150 53 5		93
5700890	6117 03 0		341					5402527	6117 96 6		352	6494477	6150 54 3		93
6213078	6117 03 1		341	5006947	6117 31 9		351	5402534	6117 96 8		352	6507191	6150 63 2		100
6459018	6117 04 1		341	5006961	6117 32 0		351	5402541	6117 97 0		352	6975686	6150 64 0		100
6459070	6117 04 3		341	6235155	6117 32 5		350	5677819	6117 97 2		351	6098170	6150 75 6		86
6459131	6117 04 5		341	6235216	6117 32 9		350	5677864	6117 98 5		349	6492251	6150 76 4		86
6459377	6117 04 7		341	6235278	6117 33 7		350	5677871	6117 98 6		349	6508037	6150 77 2		88
5700906	6117 04 8		341	6235339	6117 34 1		350	5677888	6117 98 7		349	6491773	6150 78 0		88
6213139	6117 04 9		341												
6459551	6117 05 2		341	5675112	6117 38 1		349	5696896	6119 20 2		353			€/gab.	
6459612	6117 05 4		341	5675129	6117 38 3		349	5696902	6119 20 4		353	6098293	6152 00 7		86
6459674	6117 05 6		341	5675150	6117 38 5		349	5696940	6119 20 6		353	6098354	6152 01 5		88
6459735	6117 05 8		341	5675167	6117 38 7		349	5696957	6119 20 8		353	6507610	6152 03 1		91
5700913	6117 05 9		341	5675174	6117 38 9		349	5696964	6119 21 0		353	6098477	6152 05 8		93
6213191	6117 06 0		341	5675181	6117 39 1		349	5696971	6119 21 2		353	6507375	6152 08 2		100
6459797	6117 06 3		341	5675211	6117 39 3		349	5696988	6119 21 4		354	6507252	6152 10 4		97
6459858	6117 06 5		341	5675228	6117 39 5		349	5696995	6119 21 6		354	6098712	6152 30 9		86
6459971	6117 06 7		341	5675235	6117 39 7		349	5697008	6119 21 8		354	6098774	6152 31 7		88
6460038	6117 06 9		341	6117499	6117 40 6		350	5697015	6119 22 0		354	6507795	6152 38 4		97
5700920	6117 07 0		341	5701279	6117 40 7		350	5697022	6119 22 2		354	6099139	6152 60 0		86
6213436	6117 07 1		341	6214037	6117 40 8		350	5697039	6119 22 4		354	6099191	6152 61 9		88
5437925	6117 07 4		345	6117550	6117 41 4		350	5697046	6119 22 6		355	6507733	6152 68 6		97
5437932	6117 07 6		345	5701286	6117 41 5		350	5697053	6119 22 8		355				
5437949	6117 07 8		345	6215652	6117 41 6		350	5697060	6119 23 0		355	6099559	6153 00 3		86
5437970	6117 08 0		345	6215713	6117 42 8		349	5697077	6119 23 2		354	6099610	6153 01 1		88
5700937	6117 08 1		345	6215959	6117 43 0		349	5697084	6119 23 4		354	6507917	6153 08 9		97
5437987	6117 08 2		345	6117611	6117 46 5		348	5697121	6119 23 6		354	6099979	6153 29 1		86
6460090	6117 10 2		341	5006220	6117 46 7		348	5697138	6119 23 8		353	6804498	6153 30 5		88
6460151	6117 10 4		341	6117673	6117 47 3		348	5697145	6119 24 0		353	6507856	6153 37 2		97
6460212	6117 10 6		341	5006213	6117 47 5		348	5697183	6119 24 2		353	6100392	6153 59 3		87
6460274	6117 10 8		341	5406204	6117 60 6		348	5697190	6119 24 4		353	6100453	6153 60 7		89
5700944	6117 10 9		341	5406235	6117 60 7		348	5697206	6119 24 6		353	6507672	6153 67 4		98
6213498	6117 11 0		341	5701316	6117 61 0		348	5697244	6119 24 8		353				
6460335	6117 11 1		342	5700999	6117 61 4		347	5697251	6119 25 0		354	6492138	6154 02 6		86
6460458	6117 11 3		342	5405887	6117 61 5		347					6491650	6154 03 4		88
6188956	6117 11 5		342	5405894	6117 61 6		347	5697268	6119 25 2		354	6974481	6154 06 9		97
6189014	6117 11 7		342	5275640	6117 62 0		346					6491957	6154 11 5		86
5433552	6117 11 8		342	5275688	6117 62 1		346	5697305	6119 25 4		354	6491476	6154 12 3		88
6213559	6117 11 9		342	5701019	6117 62 2		346	5697381	6119 26 2		355	6493272	6154 16 6		97
6189076	6117 12 3		342	5701033	6117 62 6		347	5697428	6119 26 4		355	6491896	6154 21 2		86
6189311	6117 12 5		342	5275749	6117 62 7		347	5697435	6119 26 6		355	6491414	6154 22 0		88
6189373	6117 12 7		342	5275756	6117 62 8		347	5697442	6119 26 8		354	6493333	6154 25 5		97
6189618	6117 12 9		342	5405924	6117 63 7		347	5697480	6119 27 0		354	6492077	6154 32 8		86
5433569	6117 13 0		342	5405931	6117 63 8		347	5697497	6119 27 2		354	6491599	6154 33 6		88
6213795	6117 13 1		342	5701064	6117 63 9		347					6974542	6154 36 0		97
6189793	6117 14 0		342	5275824	6117 64 0		347	5670865	6119 85 0		345	6492015	6154 41 7		86
6189854	6117 14 2		342	5275862	6117 64 1		347	5670872	6119 85 2		345	6491537	6154 42 5		88
6287291	6117 14 4		342	5701071	6117 64 2		347	5670889	6119 85 4		345	6493210	6154 46 8		97
6287536	6117 14 6		342	5701088	6117 64 3		347	5670896	6119 85 6		345	6491834	6154 51 4		87
5700968	6117 14 7		342	5275879	6117 64 4		347	5670902	6119 85 8		345	6491353	6154 52 2		89
6213856	6117 14 8		342	5275886	6117 64 5		347	5670919	6119 86 0		345	6493395	6154 55 7		98
6460632	6117 15 1		342	5701132	6117 65 3		347	5670926	6119 86 8		345				
6538690	6117 15 3		342	5275992	6117 65 4		347	5670957	6119 87 0		345	6543199	6156 20 7		126
6637218	6117 15 5		342	5276005	6117 65 5		347	5670964	6119 87 2		345	6543137	6156 22 3		126
6461059	6117 15 7		342	5701149	6117 65 6		347	5670971	6119 87 4		345	6543076	6156 23 1		126
5700975	6117 15 8		342	5405948	6117 65 7		347	5670988	6119 87 6		345				
6213917	6117 15 9		342	5405955	6117 65 8		347	5670995	6119 87 8		345	6577576	6158 22 6		95
6461110	6117 16 2		342	5701156	6117 66 8		346	5671008	6119 88 0		345	6577750	6158 23 4		91
6461233	6117 16 4		342	5701323	6117 66 9		346	5671015	6119 88 2		345	6577934	6158 24 2		93
6461356	6117 16 6		342	5276043	6117 67 0		346	5671022	6119 88 4		345	6578115	6158 25 0		99
6461530	6117 16 8		342	5276050	6117 67 1		346	5671039	6119 88 6		345	6578290	6158 26 9		100
5700982	6117 16 9		342	5623809	6117 67 3		346	5671046	6119 88 8		345	6578658	6158 28 5		102
6213979	6117 17 0		342	5623816	6117 67 4		346	5671084	6119 89 0		345	6578832	6158 29 3		104
5438069	6117 19 0		346					5701507	6119 99 7		349	6641352	6158 30 7		103
5483540	6117 19 1		346	6237913	6117 70 8		351	5406532	6119 99 8		349	6578955	6158 33 1		95
5438090	6117 19 2		345	6239054	6117 72 4		352	5406549	6119 99 9		349	6579136	6158 35 8		91
5483571	6117 19 3		345	6239351	6117 72 6		352					6579310	6158 36 6		93
5670933	6117 19 6		346	6239474	6117 72 8		352					6579495	6158 37 4		99
5670940	6117 19 7		346	6239535	6117 73 2		352					6579679	6158 38 2		100
5438113	6117 19 8		346	623959											

# Numeratīvs satura rādītājs

EAN numura uzbūve: valsts kods 40

ražotāja kods 1219 (art. numuriem, kas sākas ar 0: 1010)

individuālais EAN-C 5647589

EAN-C.	Art.-Nr.	Cena	Lapa	EAN-C.	Art.-Nr.	Cena	Lapa	EAN-C.	Art.-Nr.	Cena	Lapa	EAN-C.	Art.-Nr.	Cena	Lapa
6582556	6158 62 5	€/gab.	100	6108435	6161 70 7	€/gab.	119	5237488	6175 05 1	€/gab.	129	6011162	6178 34 1	€/m	178
6582914	6158 64 1		102	6108497	6161 71 5		117	5237495	6175 05 7		130			€/100	
6583096	6158 66 8		104	6108558	6161 75 8		118	5237501	6175 06 3		131	6011285	6178 34 9		184
6641710	6158 67 6		103	6501250	6161 77 4		120	5237518	6175 06 9		132			€/m	
6642618	6158 69 2		90	6580453	6161 90 1		95	5237525	6175 07 5		133	6013197	6178 42 0		179
6434473	6158 70 6		95	6580637	6161 92 8		92	5237532	6175 08 1		134	6013319	6178 42 2		179
6434534	6158 71 4		92	6580811	6161 93 6		94	5237549	6175 10 3		129	6013432	6178 42 4		179
6434596	6158 72 2		94	6580996	6161 94 4		99	5237556	6175 10 9		130	6013555	6178 42 6		179
6434657	6158 73 0		99	6581177	6161 95 2		101	5237563	6175 11 5		131	6013678	6178 42 8		180
6434718	6158 74 9		101	6581535	6161 97 9		102	5237570	6175 12 1		132	6013791	6178 43 0		180
6584178	6158 76 5		102	6641956	6161 98 7		103	5237587	6175 12 7		133	6013913	6178 43 5		180
6583270	6158 77 3		104	6581719	6161 99 5		104	5237594	6175 13 3		134	6014033	6178 43 7		180
6643158	6158 78 1		96					5237600	6175 15 0		128	6014156	6178 43 9		181
6434831	6158 80 3		103	6108619	6162 00 2		105	5237631	6175 15 6		129	6015184	6178 44 1		181
6507559	6158 83 8		91	6108671	6162 01 0		106	5237648	6175 16 2		130	5049531	6178 47 9		164
6507498	6158 84 6		93	6108732	6162 02 9		107	5237655	6175 16 8		131	6040209	6178 48 0		164
6507436	6158 88 9		100	6108978	6162 20 7		108	5237662	6175 17 4		132	6040322	6178 48 2		164
				6109036	6162 21 5		109	5237693	6175 18 0		133	6040445	6178 48 4		165
6103997	6159 37 0		123	6109098	6162 22 3		111	5237709	6175 18 6		134	6040568	6178 48 6		165
				6109159	6162 23 1		112	5237716	6175 20 4		129	6040681	6178 48 8		165
6577637	6160 01 8		95	6109210	6162 25 8		114	5237723	6175 21 0		130	6040803	6178 49 0		165
6577811	6160 02 6		91	6109272	6162 26 6		115	5237730	6175 21 6		131	6040926	6178 49 2		167
6577996	6160 03 4		93	6638710	6162 27 4		113	5237747	6175 22 2		132	6041282	6178 50 4		174
6578177	6160 04 2		99	6640096	6162 29 0		110	5237754	6175 22 8		133	6041404	6178 50 6		174
6578351	6160 05 0		100	6109333	6162 40 1		119	5237778	6175 23 4		134	6041527	6178 50 8		175
6578719	6160 07 7		102	6109395	6162 42 8		117	5237785	6175 25 5		129	6041640	6178 51 0		175
6641413	6160 08 5		103	6109456	6162 45 2		118	5237815	6175 26 1		130	6041763	6178 51 2		176
6584598	6160 09 3		104	6501618	6162 47 9		120	5237822	6175 26 7		131	6041886	6178 51 4		177
6105915	6160 10 7		105	6643219	6162 48 7		96	5237839	6175 27 3		132			€/100	
6105977	6160 11 5		106	6642670	6162 49 5		90	5237846	6175 27 9		133	6014279	6178 52 0		184
6106035	6160 12 3		107	6583454	6162 50 9		95	5237877	6175 28 5		134	6014392	6178 52 2		184
6106271	6160 30 1		108	6583577	6162 51 7		92			€/m		6014514	6178 52 7	€/gab.	184
6106332	6160 32 8		109	6583690	6162 52 5		94				164	6014637	6178 52 9		184
6106394	6160 33 6		111	6583812	6162 53 3		99	6000050	6178 00 1		164	6014750	6178 53 5		184
6106455	6160 34 4		112	6583935	6162 54 1		101	6000173	6178 00 3		164			€/100	
6106516	6160 35 2		114	6584239	6162 57 6		102	6000296	6178 00 5		164				
6106578	6160 36 0		115	6641239	6162 58 4		103	6000418	6178 01 0		164	6014873	6178 54 0		185
6638178	6160 37 9		113	6583331	6162 59 2		104	6000531	6178 01 2		165	6014996	6178 54 2		185
6639557	6160 39 5		110	6109517	6162 60 6		105	6000654	6178 01 4		165	6015061	6178 54 8		185
6106639	6160 48 4		119	6109579	6162 61 4		106	6000777	6178 01 6		165			€/m	
6106691	6160 49 2		117	6109630	6162 62 2		107	6000890	6178 01 8		165	6016266	6178 61 2		182
6106752	6160 52 2		118	6109876	6162 80 0		108	6001132	6178 02 6		166	6016389	6178 61 4		182
6502035	6160 54 9		120	6109937	6162 81 9		109	6001255	6178 02 8		166	6016501	6178 61 6		182
6579013	6160 60 3		95	6109999	6162 82 7		111	6001378	6178 03 1		166	6016747	6178 62 2		182
6579198	6160 61 1		91	6110056	6162 83 5		112	6001491	6178 03 3		166	6016860	6178 62 4		182
6579372	6160 63 8		93	6110117	6162 84 3		114	6001613	6178 03 5		167	6016983	6178 62 6		182
6579556	6160 64 6		99	6110179	6162 85 1		116	6001736	6178 03 7		167	6017102	6178 62 8		182
6579730	6160 65 4		100	6637997	6162 87 8		113	6001859	6178 03 9		167	6017225	6178 63 0		183
6580095	6160 67 0		102	6639373	6162 88 6		110	6002214	6178 05 0		167			€/100	
6641598	6160 68 9		103					6002337	6178 05 2		168	6017829	6178 65 0		184
6580279	6160 69 7		104	6110230	6163 00 9		119	6002450	6178 05 4		168			€/gab.	
6106813	6160 70 0		105	6110292	6163 01 7		117	6002573	6178 05 6		168				
6106875	6160 71 9		106	6110353	6163 04 1		118	6002696	6178 05 9		168	6674657	6182 01 1		95
6106936	6160 72 7		107	6651436	6163 07 6		120	6002818	6178 06 1		169	6674718	6182 06 2		99
6107179	6160 90 5		108							€/100		6674770	6182 09 7		102
6107230	6160 91 3		109	6782659	6168 52 3		125	6008339	6178 09 2	€/m	184	6674831	6182 10 0		103
6107292	6160 92 1		111			€/m						6674893	6182 11 9		104
6107353	6160 94 8		112	6438433	6168 70 1		97	6004850	6178 20 1		170	6674954	6182 12 7		105
6107414	6160 95 6		114	6438495	6168 72 8		97	6004973	6178 20 3		170	6675012	6182 13 5		106
6107476	6160 96 4		115	6801671	6168 73 6		97	6005093	6178 20 5		170	6675074	6182 14 3		107
6638352	6160 97 2		113	6802159	6168 74 4		97	6005215	6178 20 7		170	6675739	6182 19 4		108
6639731	6160 98 0		110			€/gab.		6005307	6178 20 9		171	6675791	6182 20 8		109
								6005406	6178 21 1		171	6675852	6182 21 6		111
6107537	6161 10 3		119	6781393	6169 29 5		123	6005505	6178 21 3		171	6675913	6182 22 4		112
6107599	6161 11 1		117	6111619	6169 30 9		122	6005802	6178 22 5		171	6675975	6182 23 2		113
6107650	6161 15 4		118	6111671	6169 31 7		123	6005932	6178 22 7		172	6676033	6182 24 0		114
6501854	6161 17 0		120	6111732	6169 32 5		124	6006052	6178 22 9		172	6676095	6182 25 9		115
6581894	6161 20 0		95	6782291	6169 36 8		123	6006175	6178 23 1		172	6676156	6182 26 7		110
6582075	6161 21 9		91	6111855	6169 37 6		123	6006298	6178 23 3		172	6676217	6182 30 5		119
6582259	6161 22 7		93	6111916	6169 38 4		123	6006410	6178 23 6		173	6676279	6182 31 3		117
6582433	6161 23 5		99	6111978	6169 39 2		124	6009411	6178 30 2		174	6676330	6182 34 8		118
6582617	6161 24 3</														

Numērāts satura rādītājs

EAN-C.	Art.-Nr.	Cena	Lapa	EAN-C.	Art.-Nr.	Cena	Lapa	EAN-C.	Art.-Nr.	Cena	Lapa	EAN-C.	Art.-Nr.	Cena	Lapa
		€/gab.				€/m				€/gab.				€/gab.	
6676750	6182 66 6		115	6363438	6191 21 5		111	6796878	6192 81 5		102	6153855	6199 18 0		158
6676811	6182 67 4		110	6363377	6191 22 3		112	6497294	6192 82 3		103	6153916	6199 18 2		158
6676873	6182 71 2		119	6491230	6191 23 1		113	6796939	6192 83 1		104	6153978	6199 18 4		158
6676934	6182 72 0		117	6363193	6191 25 8		114	6796991	6192 85 8		105	6154036	6199 18 6		158
6676996	6182 74 7		118	6794478	6191 26 6		115	6797059	6192 86 6		106			€/m	
6501793	6182 76 3		120	6799459	6191 27 4		110	6496990	6192 87 4		107	6154098	6199 20 2		160
6672851	6182 80 1		95	5042273	6191 30 4		119	6712694	6192 91 2		108	6154159	6199 20 4		160
6672912	6182 85 2		99	5042280	6191 31 2		117	6492619	6192 92 0		109	6154210	6199 20 6		160
6672974	6182 88 7		102	5042297	6191 34 7		118	6712755	6192 93 9		111	6154272	6199 20 8		160
6673032	6182 89 5		103	5042303	6191 35 5		120	6712816	6192 94 7		112			€/gab.	
6673094	6182 91 7		104			€/gab.		6492671	6192 95 5		113	6154333	6199 22 3		160
6673155	6182 92 5		105	6794652	6191 84 3		91	6712878	6192 96 3		114	6154395	6199 22 5		160
6673216	6182 93 3		106	6494651	6191 85 1		93	6797110	6192 97 1		115	6154456	6199 22 7		160
6673278	6182 94 1		107	6794713	6191 87 8		95	6492732	6192 99 8		110	6154517	6199 22 9		160
				6502219	6191 88 6		99					6154579	6199 23 2		160
6677054	6183 01 8		108	6794775	6191 89 4		100	5042488	6193 02 1		119	6154630	6199 23 4		160
6677115	6183 02 6		109	6794836	6191 92 4		102	5042570	6193 02 5		117	6154692	6199 23 6		160
6677177	6183 03 4		111	6976829	6191 93 2		103	5042648	6193 02 9		118	6155774	6199 23 8		160
6677238	6183 04 2		112	6794898	6191 94 0		104	5042716	6193 03 3		120	6155835	6199 25 1		160
6677290	6183 05 0		113	6794959	6191 95 9		105	6797172	6193 09 9		90	6155897	6199 25 3		160
6677351	6183 06 9		114	6795017	6191 96 7		106	6797233	6193 10 2		92	6155958	6199 25 5		160
6677412	6183 07 7		115	6221110	6191 97 5		107	6975624	6193 11 0		94	6156016	6199 25 7		160
6677474	6183 08 5		110					6797295	6193 12 9		95	6156078	6199 26 2		160
6677535	6183 12 3		119	6362950	6192 01 7		108	6976768	6193 13 7		96	6156139	6199 26 4		160
6677597	6183 13 1		117	6799879	6192 02 5		109	6504794	6193 14 5		99	6156313	6199 26 6		160
6677658	6183 16 6		118	6362776	6192 03 3		111	6797356	6193 15 3		101	6156375	6199 26 8		160
6501373	6183 18 2		120	6362479	6192 04 1		112	6797417	6193 18 8		102	6156559	6199 28 1		160
6673391	6183 21 2		95	6800056	6192 06 8		113	6497355	6193 19 6		103	6156498	6199 28 3		160
6673452	6183 25 5		99	6362233	6192 07 6		114	6712939	6193 21 8		104	6156610	6199 28 5		160
6673513	6183 29 8		102	6795079	6192 08 4		115	6797479	6193 22 6		105	6156672	6199 28 7		160
6673575	6183 30 1		103	6800896	6192 09 2		110	6797530	6193 23 4		106	6156795	6199 40 2		159
6673636	6183 33 6		104	5042457	6192 10 6		119	6974788	6193 24 2		107	6156733	6199 40 4		159
6673698	6183 34 4		105	5042525	6192 11 0		117	6712991	6193 28 5		108	6156856	6199 40 6		159
6673759	6183 35 2		106	5042594	6192 11 4		118	6492794	6193 29 3		109	6156979	6199 40 8		159
6673810	6183 36 0		107	5042662	6192 11 8		120	6713059	6193 30 7		111	6157037	6199 42 1		159
6677719	6183 40 9		108	6795253	6192 14 9		91	6713110	6193 31 5		112	6157099	6199 42 3		159
6677771	6183 41 7		109	6494712	6192 15 7		93	6492855	6193 32 3		113	6157211	6199 42 5		159
6677832	6183 42 5		111	6795314	6192 16 5		95	6713172	6193 33 1		114	6157570	6199 42 7		159
6677894	6183 43 3		112	6504855	6192 17 3		99	6797592	6193 35 8		116	6157938	6199 44 2		159
6677955	6183 44 1		113	6795376	6192 18 1		100	6492916	6193 36 6		110	6158294	6199 44 4		159
6678013	6183 46 8		114	6795437	6192 21 1		102	5042518	6193 38 7		119	6158652	6199 44 6		159
6678075	6183 47 6		115	6497171	6192 23 8		103	5042587	6193 39 1		117	6158713	6199 44 8		159
6678136	6183 48 4		110	6795499	6192 24 6		104	5042655	6193 39 5		118	6158775	6199 46 1		159
6678198	6183 52 2		119	6795550	6192 25 4		105	5042723	6193 39 9		120	6158836	6199 46 3		159
6678259	6183 53 0		117	6795611	6192 26 2		106	6223695	6193 50 1		91	6158898	6199 46 5		159
6678310	6183 55 7		118	6220878	6192 27 0		107	6975266	6193 52 8		93	6158959	6199 46 7		159
6222131	6183 57 3		120	6360970	6192 31 9		108	6507313	6193 56 0		100				
6673933	6183 60 3		90	6801558	6192 32 7		109								
6673995	6183 61 1		95	6354559	6192 33 5		111	6448272	6194 03 6		122	5126522	6246 05 2		315
6674053	6183 65 4		96	6353057	6192 34 3		112	6448098	6194 04 4		123	5126539	6246 08 7		315
6674114	6183 66 2		99	6492312	6192 35 1		113	6447978	6194 05 2		123			€/m	
6674176	6183 69 7		102	6351855	6192 37 8		114	6447497	6194 06 0		124	6651672	6246 96 6		138
6674237	6183 70 0		103	6795673	6192 38 6		115	6628636	6194 10 9		123	6118878	6246 97 4		139
6674299	6183 72 7		104	6492374	6192 39 4		110	6628575	6194 11 7		123	5690955	6246 98 2		140
6674350	6183 73 5		105	5042464	6192 41 6		119	6628513	6194 12 5		123	6651733	6246 99 0		141
6674411	6183 74 3		106	5042532	6192 42 0		117	6628452	6194 13 3		124				
6674473	6183 75 1		107	5042600	6192 42 4		118	6628391	6194 14 1		124	6311897	6247 01 6		143
6678372	6183 80 8		108	5042693	6192 42 8		120	6628339	6194 18 4		123	6977369	6247 09 1		145
6678433	6183 81 6		109	6796212	6192 45 9		92	6618910	6194 19 2		123	6312139	6247 11 3		147
6678495	6183 82 4		111	6494774	6192 46 7		94	6618859	6194 20 6		124	6312191	6247 14 8		149
6678556	6183 83 2		112	6796274	6192 47 5		95	6349814	6194 21 4		124	6312252	6247 16 4		151
6678617	6183 84 0		113	6504978	6192 48 3		99	6629350	6194 72 9		125	5691006	6247 19 4		153
6678679	6183 85 9		114	6796335	6192 49 1		101							€/gab.	
6678730	6183 86 7		116	6796397	6192 51 3		102					6652754	6247 43 1		138
6678792	6183 87 5		110	6497232	6192 52 1		103			€/m		6118991	6247 43 4		139
6678853	6183 91 3		119	6796458	6192 54 8		104	6096329	6199 10 3		158	6315253	6247 45 8		141
6678914	6183 92 1		117	6796519	6192 55 6		105	6096206	6199 10 5		158	6315314	6247 46 6		145
6678976	6183 95 6		118	6796571	6192 56 4		106	6096381	6199 10 7		158	5699019	6247 47 2		153
6679034	6183 98 0		120	6500833	6192 57 2		107	6096442	6199 10 9		158	6652518	6247 49 0		141
		€/m		6351794	6192 61 0		108			€/gab.		6312313	6247 50 4		143
				6492435	6192 62 9		109	6096503	6199 12 2		158	6652273	6247 56 3		141
6794058	6191 00 2														

# Numeratīvs saturs rādītājs

EAN numura uzbūve: valsts kods 40

ražotāja kods 1219 (art. numuriem, kas sākas ar 0: 1010)

individuālais EAN-C 5647589

EAN-C.	Art.-Nr.	Cena	Lapa	EAN-C.	Art.-Nr.	Cena	Lapa	EAN-C.	Art.-Nr.	Cena	Lapa	EAN-C.	Art.-Nr.	Cena	Lapa
6313099	6248 09 8	€/gab.	151	6315611	6249 96 5	€/gab.	155	5657156	6274 72 1	€/gab.	217	5658856	6277 01 0	€/gab.	224
6977185	6248 12 8		145	6315673	6249 98 1		155	5657163	6274 72 2		217	5658863	6277 01 1		224
6313396	6248 14 4		147					5657170	6274 72 6		217	5658900	6277 01 2		224
6313457	6248 15 2		149	5030898	6257 59 8		200	5657187	6274 74 0		218	5658962	6277 02 0		224
6313518	6248 16 0		151	6800711	6257 60 3		200	5657194	6274 74 1		218	5658979	6277 02 1		224
6503599	6248 18 7		145					5657200	6274 74 2		218	5658986	6277 02 2		224
6317837	6248 20 9		147	6043156	6258 06 9		356	5657217	6274 74 6		218	5659044	6277 04 0		225
6317899	6248 21 7		149	6279739	6258 07 1		356	5657224	6274 76 0		218	5659082	6277 04 1		225
6317950	6248 22 5		151	5406006	6258 07 3		356	5657231	6274 76 1		218	5659099	6277 04 2		225
6503353	6248 28 4		145	5406013	6258 07 4		356	5657248	6274 76 2		218	5659150	6277 06 0		225
6575596	6248 30 6		147	5469148	6258 14 1		348	5657255	6274 76 6		218	5659167	6277 06 1		225
6575657	6248 31 4		149					5657262	6274 77 0		218	5659204	6277 06 2		225
6575718	6248 32 2		151	5427650	6270 67 0		196	5657279	6274 77 1		218	5659228	6277 07 0		226
5699026	6248 32 8		153					5657286	6274 77 2		218	5659266	6277 07 1		226
5699033	6248 33 2		153			€/m		5657293	6274 77 6		218	5659273	6277 07 2		226
5699040	6248 33 6		153	5655473	6274 30 0		210	5657309	6274 79 0		211			€/m	
5699057	6248 34 0		153	5656333	6274 30 1		210	5657347	6274 79 1		211	5659334	6277 09 0		226
5699064	6248 34 4		153	5656340	6274 30 2		210	5657354	6274 79 2		211	5659341	6277 09 5		226
5699095	6248 42 8		153	5656371	6274 30 6		210	5657361	6274 79 6		211	5659389	6277 10 0		222
5699101	6248 43 2		153			€/gab.		5657408	6274 81 0		309	5659396	6277 10 1		222
5699118	6248 43 6		153	5656401	6274 31 0		211	5657415	6274 81 1		309	5659402	6277 10 2		222
5699125	6248 45 0		153	5656432	6274 31 1		211	5657422	6274 81 2		309			€/gab.	
5699156	6248 45 4		153	5656449	6274 31 2		211	5657460	6274 81 6		309	5659518	6277 11 0		224
		€/m		5656456	6274 31 6		211	5657477	6274 82 0		310	5659525	6277 11 1		224
6651795	6248 46 2		138	5655664	6274 32 0		211	5657484	6274 82 1		310	5659563	6277 11 2		224
6119059	6248 47 0		139	5656463	6274 32 1		211	5657521	6274 82 2		310	5659624	6277 12 0		224
5699062	6248 48 2		140	5656494	6274 32 2		211	5657538	6274 82 6		310	5659631	6277 12 1		224
6651856	6248 49 7		141	5656500	6274 32 6		211	5657545	6274 83 0		310	5659648	6277 12 2		224
6313570	6248 51 9		143	5656517	6274 34 0		212	5657583	6274 83 1		310	5659709	6277 14 0		225
6977307	6248 60 8		145	5656524	6274 34 1		212	5657590	6274 83 2		310	5659747	6277 14 1		225
6313815	6248 62 4		147	5656555	6274 34 2		212	5657606	6274 83 6		310	5659754	6277 14 2		225
6313877	6248 64 0		149	5656562	6274 34 6		212	5657644	6274 84 0		310	5659815	6277 16 0		226
6313938	6248 66 7		151	5656579	6274 36 0		212	5657651	6274 84 1		310	5659822	6277 16 1		226
5691013	6248 69 4		153	5656586	6274 36 1		212	5657668	6274 84 2		310	5659860	6277 16 2		226
		€/gab.		5656616	6274 36 2		212	5657712	6274 85 0		311	5659921	6277 17 0		226
6652570	6248 99 3		141	5656623	6274 36 6		212	5657729	6274 85 1		311	5659938	6277 17 1		226
				5656630	6274 37 0		212	5657767	6274 85 2		311	5659945	6277 17 2		226
6313990	6249 00 0		143	5656647	6274 37 1		212	5657774	6274 85 6		311			€/m	
6652334	6249 08 6		141	5656678	6274 37 2		212	5657781	6274 86 0		311	5660002	6277 20 0		227
6314232	6249 09 4		143	5656685	6274 37 6		212	5657828	6274 86 1		311	5660040	6277 20 1		227
6652211	6249 16 7		141	5656692	6274 49 0		211	5657835	6274 86 2		311	5660057	6277 20 2		227
6314478	6249 17 5		143	5656708	6274 49 1		211	5657842	6274 86 6		311			€/gab.	
6652457	6249 25 6		141	5656715	6274 49 2		211	5657880	6274 87 0		311	5660163	6277 21 0		229
6318018	6249 26 4		143	5656722	6274 49 6		211	5657897	6274 87 1		311	5660170	6277 21 1		229
6652693	6249 41 8		141			€/m		5657903	6274 87 2		311	5660187	6277 21 2		229
6575350	6249 42 6		144	5656739	6274 50 0		213	5657941	6274 87 6		311	5660248	6277 22 0		229
6503414	6249 48 5		145	5656746	6274 50 1		213	5657958	6274 88 0		312	5660286	6277 22 1		229
6314713	6249 50 7		147	5656753	6274 50 2		213	5657965	6274 88 1		312	5660293	6277 22 2		229
6314775	6249 51 5		149	5656760	6274 50 6		213	5658009	6274 88 2		312	5660323	6277 24 0		230
6314836	6249 52 3		151			€/gab.		5658023	6274 89 0		211	5660330	6277 24 1		230
6503650	6249 55 8		145	5656791	6274 51 0		214	5658061	6274 89 1		211	5660347	6277 24 2		230
6314898	6249 57 4		147	5656807	6274 51 1		214	5658078	6274 89 2		211	5660408	6277 26 0		230
6314959	6249 58 2		149	5656814	6274 51 2		214	5658085	6274 89 6		211	5660415	6277 26 1		230
6315017	6249 59 0		151	5656821	6274 51 6		214			€/m		5660422	6277 26 2		230
6977123	6249 61 2		145	5656838	6274 52 0		214	5658122	6274 90 0		212	5660484	6277 27 0		231
6315079	6249 63 9		147	5656845	6274 52 1		214			€/gab.		5660521	6277 27 1		231
6315130	6249 64 7		149	5656852	6274 52 2		214	5658139	6274 91 0		310	5660538	6277 27 2		231
6315192	6249 65 5		151	5656869	6274 52 6		214	5658146	6274 91 1		310	5660590	6277 29 0		222
6503537	6249 67 1		145	5656876	6274 54 0		215	5658184	6274 91 2		310	5700852	6277 29 4		222
6318254	6249 70 1		147	5656883	6274 54 1		215	5658207	6274 92 0		310			€/m	
6318315	6249 72 8		149	5656890	6274 54 2		215	5658245	6274 92 1		310	5660606	6277 30 0		227
6318377	6249 73 6		151	5656906	6274 54 6		215	5658252	6274 92 2		310	5660644	6277 30 1		227
6503292	6249 79 5		145	5656913	6274 56 0		215	5658306	6274 93 0		310	5660651	6277 30 2		227
6575770	6249 81 7		147	5656920	6274 56 1		215	5658313	6274 93 1		310			€/gab.	
6575831	6249 82 5		149	5656937	6274 56 2		215	5658320	6274 93 2		310	5660767	6277 31 0		229
6575893	6249 83 3		151	5656944	6274 56 6		215	5658375	6274 94 0		311	5660774	6277 31 1		229
6018598	6249 84 2		138	5656951	6274 57 0		215	5658382	6274 94 1		311	5660781	6277 31 2		229
6018710	6249 84 4		139	5656968	6274 57 1		215	5658429	6274 94 2		311	5660811	6277 32 0		230
5691020	6249 84 5		140	5656975	6274 57 2		215	5658443	6274 95 0		311	5660828	6277 32 1		230
6018833	6249 84 6		142	5656982	6274 57 6		215	5658481	6274 95 1		311	5660835	6277 32 2		230
6018956	6249 84 8		144	5656999	6274 59 0		212	5658498	6274 95 2		311	5660866	6277 34 0		230
6019076	6249 85 0		146	5657002	6274 59 1		212	5658542	6274 96 0		311	5660873	6277 34 1		230
5020325	6249 85 2		148	5657019	6274 59 2		212	5658559	6274 96 1		311	5660880	6277 34 2		230
5020387	6249 85 4		150	5657026	6274 59 6		212	5658566	6274 96 2		311	5660941	6277 36 0		231
5020394	6249 85 6		152	5657033	6274 65 0		210	5658580	6274 97 0		312	5660958	6277 36 1		231
5691037	6249 86 5		154			€/m		5658597	6274 97 1		312	5660965	6277 36 2		231
		€/m		5657040	6274 70 0		216	5658603	6274 97 2		312	5661023	6277 37 0		231
6644896	6249 87 6		155	5657057	6274 70 1		216	5658627	6274 98 0		312	5661061	6277 37 1		231
		€/gab.		5657064	6274 70 2		216	5658665	6274 98 1		312	5661078	6277 37 2		231
5685081															

Numeratīvs satura rādītājs

EAN-C.	Art.-Nr.	Cena	Lapa	EAN-C.	Art.-Nr.	Cena	Lapa	EAN-C.	Art.-Nr.	Cena	Lapa	EAN-C.	Art.-Nr.	Cena	Lapa
5661313	6277 41 2	€/gab.	234	5663164	6277 83 2	€/gab.	246	5664918	6278 23 1	€/gab.	251	5666820	6278 82 2	€/gab.	313
5661375	6277 42 0		234	5663195	6277 84 0		246	5664925	6278 23 2		251	5666875	6278 83 0		313
5661382	6277 42 1		234	5663201	6277 84 1		246	5664987	6278 24 0		252	5666882	6278 83 1		313
5661429	6277 42 2		234	5663218	6277 84 2		246	5665021	6278 24 1		252	5666899	6278 83 2		313
5661443	6277 43 0		235	5663249	6277 86 0		247	5665038	6278 24 2		252	5666929	6278 84 0		313
5661481	6277 43 1		235	5663270	6277 86 1		247	5665083	6278 26 0		252	5666936	6278 84 1		313
5661498	6277 43 2		235	5663287	6277 86 2		247	5665090	6278 26 1		252	5666943	6278 84 2		313
5661559	6277 44 0		235			€/m	243	5665106	6278 26 2		252	5666974	6278 85 0		314
5661566	6277 44 1		235	5663317	6277 90 0		243			€/m		5666981	6278 85 1		314
5661603	6277 44 2		235	5663324	6277 90 1		243	5665137	6278 30 0		249	5666998	6278 85 2		314
5661665	6277 46 0		236	5663331	6277 90 2		243	5665144	6278 30 1		249	5667025	6278 86 0		314
5661672	6277 46 1		236			€/gab.		5665151	6278 30 2		249	5667056	6278 86 1		314
5661689	6277 46 2		236	5663409	6277 91 0		245			€/gab.		5667063	6278 86 2		314
		€/m		5663416	6277 91 1		245	5665205	6278 31 0		251	5667094	6278 87 0		314
5661740	6277 50 0		232	5663423	6277 91 2		245	5665212	6278 31 1		251	5667100	6278 87 1		314
5661788	6277 50 1		232	5663478	6277 92 0		245	5665229	6278 31 2		251	5667117	6278 87 2		314
5661795	6277 50 2		232	5663485	6277 92 1		245	5665250	6278 32 0		251	5667148	6278 88 0		312
		€/gab.		5663515	6277 92 2		245	5665267	6278 32 1		251	5667179	6278 88 1		312
5661900	6277 51 0		234	5663539	6277 93 0		246	5665274	6278 32 2		251	5667186	6278 88 2		312
5661917	6277 51 1		234	5663546	6277 93 1		246	5665335	6278 33 0		251	5667216	6278 89 0		313
5661924	6277 51 2		234	5663577	6277 93 2		246	5665342	6278 33 1		251	5667223	6278 89 1		313
5661986	6277 52 0		234	5663607	6277 94 0		246	5665380	6278 33 2		251	5667230	6278 89 2		313
5661993	6277 52 1		234	5663638	6277 94 1		246	5665458	6278 34 0		252				
5662006	6277 52 2		234	5663645	6277 94 2		246	5665465	6278 34 1		252	5667261	6279 00 0		313
5662020	6277 53 0		235	5663690	6277 96 0		247	5665472	6278 34 2		252	5667278	6279 00 1		313
5662037	6277 53 1		235	5663706	6277 96 1		247	5665502	6278 36 0		252	5667285	6279 00 2		313
5662044	6277 53 2		235	5663713	6277 96 2		247	5665519	6278 36 1		252	5667315	6279 01 0		313
5662075	6277 54 0		235			€/m		5665526	6278 36 2		252	5667322	6279 01 1		313
5662082	6277 54 1		235							€/m		5667353	6279 01 2		313
5662099	6277 54 2		235	5663744	6278 00 0		254	5665557	6278 40 0		260	5667384	6279 02 0		314
5662129	6277 56 0		236	5663751	6278 00 1		254	5665564	6278 40 1		260	5667414	6279 02 1		314
5662136	6277 56 1		236	5663768	6278 00 2		254	5665571	6278 40 2		260	5667421	6279 02 2		314
5662143	6277 56 2		236			€/gab.				€/gab.		5667476	6279 03 0		314
		€/m		5663812	6278 01 0		256	5665625	6278 41 0		262	5667483	6279 03 1		314
5662174	6277 60 0		238	5663829	6278 01 1		256	5665632	6278 41 1		262	5667490	6279 03 2		314
5662181	6277 60 1		238	5663836	6278 01 2		256	5665649	6278 41 2		262	5667520	6279 04 0		314
5662198	6277 60 2		238	5663867	6278 02 0		256	5665700	6278 42 0		262	5667537	6279 04 1		314
		€/gab.		5663874	6278 02 1		256	5665755	6278 42 1		262	5667544	6279 04 2		314
5662242	6277 61 0		240	5663881	6278 02 2		256	5665762	6278 42 2		262	5667599	6279 05 0		315
5662259	6277 61 1		240	5663904	6278 03 0		257	5665816	6278 43 0		263	5667605	6279 05 1		315
5662266	6277 61 2		240	5663911	6278 03 1		257	5665823	6278 43 1		263	5667612	6279 05 2		315
5662310	6277 62 0		240	5663928	6278 03 2		257	5665878	6278 43 2		263	5667667	6279 06 0		223
5662327	6277 62 1		240	5663959	6278 05 0		257	5665939	6278 44 0		263	5667674	6279 06 1		223
5662334	6277 62 2		240	5663966	6278 05 1		257	5665946	6278 44 1		263	5667681	6279 06 2		223
5662365	6277 64 0		241	5663973	6278 05 2		257	5665984	6278 44 2		263	5667704	6279 06 4		228
5662372	6277 64 1		241	5664000	6278 06 0		258	5666042	6278 46 0		264	5667711	6279 06 5		228
5662389	6277 64 2		241	5664017	6278 06 1		258	5666059	6278 46 1		264	5667728	6279 06 6		228
5662419	6277 66 0		241	5664024	6278 06 2		258	5666066	6278 46 2		264	5667742	6279 06 8		239
5662426	6277 66 1		241	5664055	6278 07 0		258			€/m		5667759	6279 06 9		239
5662433	6277 66 2		241	5664062	6278 07 1		258	5666097	6278 50 0		260	5667766	6279 07 0		239
5662464	6277 67 0		242	5664079	6278 07 2		258	5666103	6278 50 1		260	5667780	6279 07 2		255
5662471	6277 67 1		242			€/m		5666110	6278 50 2		260	5667797	6279 07 3		255
5662488	6277 67 2		242	5664109	6278 10 0		254			€/gab.		5667803	6279 07 4		255
		€/m		5664116	6278 10 1		254	5666165	6278 51 0		262	5667827	6279 07 6		223
5662518	6277 70 0		238	5664123	6278 10 2		254	5666172	6278 51 1		262	5667834	6279 07 7		223
5662525	6277 70 1		238			€/gab.		5666189	6278 51 2		262	5667841	6279 07 8		223
5662532	6277 70 2		238	5664178	6278 11 0		256	5666219	6278 52 0		262	5667865	6279 08 0		229
		€/gab.		5664185	6278 11 1		256	5666226	6278 52 1		262	5667872	6279 08 1		229
5662587	6277 71 0		240	5664192	6278 11 2		256	5666233	6278 52 2		262	5667889	6279 08 2		229
5662594	6277 71 1		240	5664222	6278 12 0		256	5666257	6278 53 0		263	5667902	6279 08 4		239
5662600	6277 71 2		240	5664239	6278 12 1		256	5666264	6278 53 1		263	5667919	6279 08 5		239
5662631	6277 72 0		240	5664246	6278 12 2		256	5666271	6278 53 2		263	5667926	6279 08 6		239
5662648	6277 72 1		240	5664260	6278 13 0		257	5666301	6278 54 0		263	5667940	6279 08 8		255
5662679	6277 72 2		240	5664307	6278 13 1		257	5666318	6278 54 1		263	5667957	6279 08 9		255
5662709	6277 74 0		241	5664314	6278 13 2		257	5666325	6278 54 2		263	5667964	6279 09 0		255
5662716	6277 74 1		241	5664376	6278 14 0		257	5666356	6278 56 0		264	5680680	6279 80 0		307
5662723	6277 74 2		241	5664383	6278 14 1		257	5666363	6278 56 1		264	5680697	6279 80 2		306
5662754	6277 76 0		241	5664420	6278 14 2		257	5666370	6278 56 2		264	5680703	6279 80 4		306
5662761	6277 76 1		241	5664482	6278 16 0		258			€/m		5680734	6279 80 6		306
5662815	6277 76 2		241	5664499	6278 16 1		258	5666400	6278 68 0		210	5680741	6279 81 0		306
5662877	6277 77 0		242	5664505	6278 16 2		258	5666417	6278 68 1		210	5680758	6279 81 2		306
5662884	6277 77 1		242	5664567	6278 17 0		258	5666424	6278 68 2		21				

# Numeratīvs saturs rādītājs

EAN numura uzbūve: valsts kods 40

ražotāja kods 1219 (art. numuriem, kas sākas ar 0: 1010)

individuālais EAN-C 5647589

EAN-C.	Art.-Nr.	Cena	Lapa	EAN-C.	Art.-Nr.	Cena	Lapa	EAN-C.	Art.-Nr.	Cena	Lapa	EAN-C.	Art.-Nr.	Cena	Lapa
5695868	6279 85 2	€/m	223	5141778	6284 81 3	€/gab.	287	5142546	6285 37 0	€/gab.	303	5157663	6287 22 0	€/gab.	294
		€/gab.		5141785	6284 82 0		287	5142553	6285 37 3		303	5157670	6287 22 3		294
5695936	6279 86 0		225	5141815	6284 82 3		287			€/m	268	5157687	6287 23 0		293
5695943	6279 86 1		225	5141822	6284 83 0		287	5157069	6285 40 0		268	5157724	6287 23 3		293
5695981	6279 86 2		225	5141839	6284 83 3		287	5157076	6285 40 3		268			€/m	
5696056	6279 87 0		224	5141846	6284 84 0		287			€/gab.	269	5146575	6287 70 0		309
5696063	6279 87 1		224	5141877	6284 84 3		287	5157083	6285 41 0		269	5146582	6287 70 1		309
5696100	6279 87 2		224	5141884	6284 86 0		288	5157120	6285 41 3		269	5146612	6287 70 2		309
		€/m		5141891	6284 86 3		288	5157137	6285 42 0		269	5146643	6287 71 0		309
5680925	6279 88 0		250	5141907	6284 87 0		288	5157144	6285 42 3		269	5146674	6287 71 1		309
5680932	6279 88 1		250	5141938	6284 87 3		288	5157182	6285 43 0		269	5146681	6287 71 2		309
5680949	6279 88 2		250			€/m		5157199	6285 43 3		269	5146704	6287 72 3		309
		€/gab.		5141945	6284 90 0		289	5157205	6285 44 0		269	5146742	6287 73 3		309
5681090	6279 99 0		252	5141952	6284 90 3		289	5157243	6285 44 3		269			€/gab.	
5681106	6279 99 1		252			€/gab.		5157250	6285 46 0		270	5146766	6287 80 0		309
5681113	6279 99 2		252	5141969	6284 91 0		290	5157267	6285 46 3		270	5146797	6287 81 0		309
		€/m		5141990	6284 91 3		290	5157304	6285 47 0		270				
5140870	6284 40 0		274	5142003	6284 92 0		290	5157311	6285 47 3		270	5676140	6288 00 1		306
5140887	6284 40 3		274	5142010	6284 92 3		290			€/m	271	5676188	6288 00 3		306
		€/gab.		5142027	6284 93 0		290	5157328	6285 50 0		271	5676195	6288 00 5		306
5140917	6284 41 0		275	5142058	6284 93 3		290	5157366	6285 50 3		271	5676201	6288 00 7		306
5140924	6284 41 3		275	5142065	6284 94 0		290			€/gab.	272	5146865	6288 03 0		308
5140931	6284 42 0		275	5142072	6284 94 3		290	5157373	6285 51 0		272	5146872	6288 03 2		308
5140948	6284 42 3		275	5142089	6284 96 0		291	5157380	6285 51 3		272	5146889	6288 03 4		308
5140979	6284 43 0		275	5142119	6284 96 3		291	5157427	6285 52 0		272	5146919	6288 03 6		308
5140986	6284 43 3		275	5142126	6284 97 0		291	5157434	6285 52 3		272	5146926	6288 03 8		308
5140993	6284 44 0		275	5142133	6284 97 3		291	5157441	6285 53 0		272	5146933	6288 04 0		308
5141006	6284 44 3		275			€/m		5157489	6285 53 3		272	5146940	6288 04 2		308
5141044	6284 46 0		276	5156581	6285 00 0		292	5157496	6285 54 0		272	5146971	6288 04 4		308
5141051	6284 46 3		276	5156598	6285 00 3		292	5157502	6285 54 3		272	5146988	6288 04 6		308
5141068	6284 47 0		276			€/gab.		5157540	6285 56 0		273	5146995	6288 04 8		308
5141099	6284 47 3		276	5156604	6285 01 0		293	5157557	6285 56 3		273	5147008	6288 05 0		308
		€/m		5156642	6285 01 3		293	5157564	6285 57 0		273	5147039	6288 05 2		308
5141105	6284 50 0		277	5156659	6285 02 0		293	5157601	6285 57 3		273	5147046	6288 05 4		308
5141112	6284 50 3		277	5156666	6285 02 3		293			€/m	320	5147053	6288 05 6		308
		€/gab.		5156703	6285 03 0		293	5142560	6286 00 0		320	5147060	6288 05 8		308
5141129	6284 51 0		278	5156710	6285 03 3		293	5142607	6286 00 3		320	5147091	6288 06 0		308
5141150	6284 51 3		278	5156727	6285 04 0		293	5142980	6286 11 0		320	5147107	6288 06 2		308
5141167	6284 52 0		278	5156765	6285 04 3		294	5143017	6286 11 3		320	5147114	6288 06 4		308
5141174	6284 52 3		278	5156772	6285 06 0		294	5143079	6286 13 0		320	5147121	6288 06 6		308
5141181	6284 53 0		278	5156789	6285 06 3		294	5143086	6286 13 3		320	5297185	6288 07 0		308
5141211	6284 53 3		278			€/m		5143161	6286 16 0		320	5297192	6288 07 2		308
5141228	6284 54 0		278	5156826	6285 10 0		295	5143192	6286 16 3		320	5297208	6288 07 4		308
5141235	6284 54 3		278	5156833	6285 10 3		295	5143208	6286 17 0		320	5297215	6288 07 6		308
5141242	6284 56 0		279			€/gab.		5143222	6286 17 3		320	5297222	6288 07 8		308
5141273	6284 56 3		279	5156840	6285 11 0		296	5143284	6286 19 0		320	5297239	6288 08 0		308
5141280	6284 57 0		279	5156888	6285 11 3		296	5143314	6286 19 3		320	5297246	6288 08 2		308
5141297	6284 57 3		279	5156895	6285 12 0		296	5143321	6286 20 0		320	5297253	6288 08 4		308
		€/m		5156901	6285 12 3		296	5143338	6286 20 3		320	5297260	6288 08 6		308
5141303	6284 60 0		280	5156949	6285 13 0		296	5143383	6286 22 0		320	5297277	6288 08 8		308
5141334	6284 60 3		280	5156956	6285 13 3		296	5143406	6286 22 3		320	5297284	6288 09 0		308
		€/gab.		5156963	6285 14 0		297	5143451	6286 25 0		320	5297291	6288 09 2		308
5141341	6284 61 0		281	5157007	6285 14 3		297	5143499	6286 25 3		320	5147152	6288 10 0		307
5141358	6284 61 3		281	5157014	6285 16 0		297	5143567	6286 29 0		320	5147169	6288 10 2		307
5141365	6284 62 0		281	5157021	6285 16 3		297	5143574	6286 29 3		320	5147176	6288 10 4		307
5141396	6284 62 3		281			€/m		5143734	6286 50 0		336	5147183	6288 10 6		307
5141402	6284 63 0		281	5142140	6285 20 0		298	5143741	6286 50 2		336	5147213	6288 10 8		307
5141419	6284 63 3		281	5142171	6285 20 3		298	5143758	6286 50 3		336	5147220	6288 11 0		307
5141426	6284 64 0		281			€/gab.		5143765	6286 55 0		318	5147237	6288 11 2		307
5141457	6284 64 3		281	5142188	6285 21 0		299	5143819	6286 56 0		318	5147244	6288 11 4		307
5141464	6284 66 0		282	5142195	6285 21 3		299	5143888	6286 70 0		334	5147275	6288 11 6		307
5141471	6284 66 3		282	5142201	6285 22 0		299	5143918	6286 70 2		334	5147282	6288 11 8		307
5141488	6284 67 0		282	5142232	6285 22 3		299			€/m	320	5147299	6288 12 0		307
5141518	6284 67 3		282	5142249	6285 23 0		299	5143925	6286 75 0		320	5147404	6288 18 0		308
		€/m		5142256	6285 23 3		299	5143932	6286 75 2		320	5616559	6288 36 5		358
5141525	6284 70 0		283	5142263	6285 24 0		299	5143949	6286 75 4		320	5694915	6288 36 9		358
5141532	6284 70 3		283	5142294	6285 24 3		299	5143970	6286 75 6		320	5148562	6288 57 0		333
		€/gab.		5142300	6285 26 0		300	5143987	6286 75 8		320	5148579	6288 57 1		333
5141549	6284 71 0		284	5142317	6285 26 3		300			€/gab.	320	5480969	6288 57 5		340
5141570	6284 71 3		284	5142324	6285 27 0		300	5143994	6286 77 0		320	5148586	6288 58 0		333
5141587	6284 72 0		284	5142355	6285 27 3		300	5144007	6286 77 2		320	5148593	6288 58 1		333
5141594	6284 72 3		284			€/m		5144038	6286						

EAN-C.	Art.-Nr.	Cena	Lapa	EAN-C.	Art.-Nr.	Cena	Lapa
		€/gab.				€/gab.	
5404484	<b>6288 62 6</b>		357	5418566	<b>6290 26 0</b>		322
5404491	<b>6288 62 7</b>		357	5428169	<b>6290 26 4</b>		328
5404507	<b>6288 62 8</b>		357	5448792	<b>6290 26 9</b>		329
5404514	<b>6288 62 9</b>		357	5648963	<b>6290 29 0</b>		329
5404521	<b>6288 63 0</b>		357				
5404538	<b>6288 63 1</b>		358	5733195	<b>9002 09 7</b>		309
5404545	<b>6288 63 2</b>		358				
5404552	<b>6288 63 3</b>		358				
5148777	<b>6288 64 0</b>		212				
5148791	<b>6288 65 0</b>		315				
		€/m					
5685760	<b>6288 65 1</b>		315				
		€/gab.					
5148913	<b>6288 66 7</b>		268				
5149088	<b>6288 70 0</b>		223				
5149101	<b>6288 70 4</b>		226				
5149460	<b>6288 79 0</b>		210				
		€/m					
5149521	<b>6288 83 0</b>		320				
		€/gab.					
5160564	<b>6288 92 0</b>		322				
5160601	<b>6288 92 3</b>		322				
5160663	<b>6288 93 0</b>		321				
5160670	<b>6288 93 3</b>		321				
5160731	<b>6288 94 0</b>		324				
5160748	<b>6288 94 3</b>		324				
5160809	<b>6288 95 0</b>		325				
5160847	<b>6288 95 3</b>		325				
5160861	<b>6288 96 0</b>		326				
5160908	<b>6288 96 3</b>		326				
5160960	<b>6288 97 0</b>		327				
5160977	<b>6288 97 3</b>		327				
5477013	<b>6289 04 0</b>		330				
5477402	<b>6289 04 3</b>		330				
5477419	<b>6289 05 0</b>		331				
5477020	<b>6289 05 3</b>		331				
5477037	<b>6289 06 0</b>		329				
5477426	<b>6289 06 3</b>		329				
5477433	<b>6289 07 0</b>		331				
5477044	<b>6289 07 3</b>		331				
5161202	<b>6290 01 0</b>		323				
5161219	<b>6290 01 3</b>		323				
5161226	<b>6290 02 0</b>		335				
5161264	<b>6290 02 3</b>		335				
5161288	<b>6290 03 0</b>		335				
5161325	<b>6290 03 3</b>		335				
5161349	<b>6290 04 0</b>		335				
5161387	<b>6290 04 3</b>		335				
5161448	<b>6290 05 0</b>		335				
5161455	<b>6290 05 3</b>		335				
5161509	<b>6290 06 0</b>		335				
5161516	<b>6290 06 3</b>		335				
5161561	<b>6290 07 3</b>		336				
5428077	<b>6290 08 2</b>		328				
5428084	<b>6290 08 3</b>		328				
5428091	<b>6290 08 6</b>		327				
5428107	<b>6290 08 7</b>		327				
5428138	<b>6290 09 0</b>		336				
5428145	<b>6290 09 1</b>		336				
5161578	<b>6290 10 0</b>		324				
5161585	<b>6290 10 4</b>		324				
5161639	<b>6290 11 0</b>		325				
5161646	<b>6290 11 4</b>		325				
5161691	<b>6290 12 0</b>		321				
5161707	<b>6290 12 4</b>		321				
5161752	<b>6290 13 0</b>		326				
5161769	<b>6290 13 4</b>		326				
5161813	<b>6290 15 0</b>		321				
5161868	<b>6290 16 0</b>		321				
5161882	<b>6290 17 0</b>		324				
5161929	<b>6290 17 2</b>		325				
5161936	<b>6290 17 4</b>		321				
5161943	<b>6290 17 6</b>		326				
5428152	<b>6290 17 8</b>		328				
5161981	<b>6290 18 0</b>		333				
5162001	<b>6290 18 4</b>		333				
5459231	<b>6290 19 6</b>		328				
5459248	<b>6290 19 7</b>		328				
5459279	<b>6290 19 8</b>		328				
5162063	<b>6290 20 0</b>		322				
5465249	<b>6290 20 1</b>		333				
5162117	<b>6290 22 0</b>		325				
5162162	<b>6290 24 0</b>		324				
5162179	<b>6290 25 0</b>		327				

06 LFS\_Katalog\_2010\_Neuer\_Stand // v / 12/07/2011 / LLEExport\_01304

# Tipu saraksts

EAN numura uzbūve: valsts kods 40

ražotāja kods 1219 (art. numuriem, kas sākas ar 0: 1010)

individuālais EAN-C 5647589

Tips	Izmērs/krāsa/cits	EAN-C.	Art.-Nr.	Cena	Lapa	Tips	Izmērs/krāsa/cits	EAN-C.	Art.-Nr.	Cena	Lapa
7LSB	300	5148791	6288 65 0	€/gab.	315	71GD6	pelēks / PA	5148746	6288 61 5	€/gab.	295
7LSB M		5685760	6288 65 1	€/m	315	71GD6	pelēks / PA	5148746	6288 61 5		298
				€/gab.		71GD6	pelēks / PA	5148746	6288 61 5		301
						71GD6	pelēks / PA	5148746	6288 61 5		333
7ZE	/ PA	5149460	6288 79 0		210	71GD7	pelēks / PA	5148685	6288 61 1		210
7ZE	/ PA	5149460	6288 79 0		213	71GD7	pelēks / PA	5148685	6288 61 1		213
7ZE	/ PA	5149460	6288 79 0		216	71GD7	pelēks / PA	5148685	6288 61 1		216
7ZE	/ PA	5149460	6288 79 0		223	71GD7	pelēks / PA	5148685	6288 61 1		222
7ZE	/ PA	5149460	6288 79 0		228	71GD7	pelēks / PA	5148685	6288 61 1		227
7ZE	/ PA	5149460	6288 79 0		233	71GD7	pelēks / PA	5148685	6288 61 1		232
7ZE	/ PA	5149460	6288 79 0		239	71GD7	pelēks / PA	5148685	6288 61 1		238
7ZE	/ PA	5149460	6288 79 0		244	71GD7	pelēks / PA	5148685	6288 61 1		243
7ZE	/ PA	5149460	6288 79 0		250	71GD7	pelēks / PA	5148685	6288 61 1		249
7ZE	/ PA	5149460	6288 79 0		255	71GD7	pelēks / PA	5148685	6288 61 1		254
7ZE	/ PA	5149460	6288 79 0		261	71GD7	pelēks / PA	5148685	6288 61 1		260
7ZE	/ PA	5149460	6288 79 0		268	71GD7	pelēks / PA	5148685	6288 61 1		268
7ZE	/ PA	5149460	6288 79 0		271	71GD7	pelēks / PA	5148685	6288 61 1		271
7ZE	/ PA	5149460	6288 79 0		274	71GD7	pelēks / PA	5148685	6288 61 1		274
7ZE	/ PA	5149460	6288 79 0		277	71GD7	pelēks / PA	5148685	6288 61 1		277
7ZE	/ PA	5149460	6288 79 0		280	71GD7	pelēks / PA	5148685	6288 61 1		280
7ZE	/ PA	5149460	6288 79 0		283	71GD7	pelēks / PA	5148685	6288 61 1		283
7ZE	/ PA	5149460	6288 79 0		286	71GD7	pelēks / PA	5148685	6288 61 1		286
7ZE	/ PA	5149460	6288 79 0		289	71GD7	pelēks / PA	5148685	6288 61 1		289
7ZE	/ PA	5149460	6288 79 0		292	71GD7	pelēks / PA	5148685	6288 61 1		292
7ZE	/ PA	5149460	6288 79 0		295	71GD7	pelēks / PA	5148685	6288 61 1		295
7ZE	/ PA	5149460	6288 79 0		298	71GD7	pelēks / PA	5148685	6288 61 1		298
7ZE	/ PA	5149460	6288 79 0		301	71GD7	pelēks / PA	5148685	6288 61 1		301
7ZE	/ PA	5149460	6288 79 0		340	71GD7	pelēks / PA	5148685	6288 61 1		333
						71GD7	pelēks / PA	5148685	6288 61 1		337
8AWR	/ gab. / G	5149101	6288 70 4		226	71GD8	pelēks / PA	5148562	6288 57 0		333
8AWR	/ gab. / G	5149101	6288 70 4		231	71GD8	pelēks / PA	5148562	6288 57 0		337
8AWR	/ gab. / G	5149101	6288 70 4		237	71GD8	pelēks / PA	5148562	6288 57 0		340
8AWR	/ gab. / G	5149101	6288 70 4		242	71GD8	pelēks / PA	5148579	6288 57 1		333
8AWR	/ gab. / G	5149101	6288 70 4		248	71GD8	pelēks / PA	5148579	6288 57 1		337
8AWR	/ gab. / G	5149101	6288 70 4		253	71GD8	pelēks / PA	5148579	6288 57 1		340
8AWR	/ gab. / G	5149101	6288 70 4		259	71GD9	pelēks / PA	5148586	6288 58 0		333
8AWR	/ gab. / G	5149101	6288 70 4		265	71GD9	pelēks / PA	5148586	6288 58 0		337
						71GD9	pelēks / PA	5148586	6288 58 0		340
8VS4		5146797	6287 81 0		309	71GD9	pelēks / PA	5148593	6288 58 1		333
						71GD9	pelēks / PA	5148593	6288 58 1		337
						71GD9	pelēks / PA	5148593	6288 58 1		340
71GD6	pelēks / PA	5148678	6288 61 0		210	71GD9	pelēks / PA	5148593	6288 58 1		340
71GD6	pelēks / PA	5148678	6288 61 0		213						
71GD6	pelēks / PA	5148678	6288 61 0		216	71MT3 45	pelēks / PA	5480969	6288 57 5		340
71GD6	pelēks / PA	5148678	6288 61 0		222						
71GD6	pelēks / PA	5148678	6288 61 0		227						
71GD6	pelēks / PA	5148678	6288 61 0		232						
71GD6	pelēks / PA	5148678	6288 61 0		238	910 SD 6X35	635/ PA	5669197	2351 05 6	€/100 gab.	125
71GD6	pelēks / PA	5148678	6288 61 0		243						
71GD6	pelēks / PA	5148678	6288 61 0		249						
71GD6	pelēks / PA	5148678	6288 61 0		254	2064 GTP 2M	1,5/ St / GTP	5044291	1115 05 7	€/100 m	185
71GD6	pelēks / PA	5148678	6288 61 0		260	2064 GTP 2M	1,5/ St / GTP	5044352	1115 06 5		185
71GD6	pelēks / PA	5148678	6288 61 0		268						
71GD6	pelēks / PA	5148678	6288 61 0		271	2069 2M GTP	1/ St / GTP	5045434	1115 65 0		185
71GD6	pelēks / PA	5148678	6288 61 0		274	2069 2M GTP	1/ gab. / GTP	5045496	1115 66 9		185
71GD6	pelēks / PA	5148678	6288 61 0		277						
71GD6	pelēks / PA	5148678	6288 61 0		280						
71GD6	pelēks / PA	5148678	6288 61 0		283						
71GD6	pelēks / PA	5148678	6288 61 0		286	2370 110	akmens pelēks 95,7/ PVC	6026173	6023 51 7	€/100 gab.	121
71GD6	pelēks / PA	5148678	6288 61 0		289	2370 130	akmens pelēks 116,2/ PVC	6026234	6023 52 5		121
71GD6	pelēks / PA	5148678	6288 61 0		292	2370 150	akmens pelēks 136,2/ PVC	6637874	6023 53 3		121
71GD6	pelēks / PA	5148678	6288 61 0		295	2370 170	akmens pelēks 156,7/ PVC	6026296	6023 54 1		121
71GD6	pelēks / PA	5148678	6288 61 0		298	2370 210	akmens pelēks 197,2/ PVC	6026357	6023 57 6		121
71GD6	pelēks / PA	5148678	6288 61 0		301	2370 230	akmens pelēks 216,2/ PVC	6639250	6023 58 4		122
71GD6	pelēks / PA	5148678	6288 61 0		333	2370 60	akmens pelēks 48,8/ PVC	6023776	6022 99 5		121
71GD6	pelēks / PA	5148678	6288 61 0		337	2370 90	akmens pelēks 75,7/ PVC	6026111	6023 50 9		121
71GD6	pelēks / PA	5148746	6288 61 5		210						
71GD6	pelēks / PA	5148746	6288 61 5		213						
71GD6	pelēks / PA	5148746	6288 61 5		216	2371 100	gaiši pelēks 2000/ PVC	6030736	6026 99 0	€/m	122
71GD6	pelēks / PA	5148746	6288 61 5		222	2371 40	gaiši pelēks 2000/ PVC	6024315	6023 09 6		122
71GD6	pelēks / PA	5148746	6288 61 5		227	2371 40	gaiši pelēks 2000/ PVC	6024315	6023 09 6		188
71GD6	pelēks / PA	5148746	6288 61 5		232	2371 40	gaiši pelēks 2000/ PVC	6024315	6023 09 6		191
71GD6	pelēks / PA	5148746	6288 61 5		238	2371 40	gaiši pelēks 2000/ PVC	6024315	6023 09 6		194
71GD6	pelēks / PA	5148746	6288 61 5		243	2371 40	gaiši pelēks 2000/ PVC	6024315	6023 09 6		200
71GD6	pelēks / PA	5148746	6288 61 5		249	2371 40	gaiši pelēks 2000/ PVC	6024315	6023 09 6		204
71GD6	pelēks / PA	5148746	6288 61 5		254	2371 60	gaiši pelēks 2000/ PVC	6024377	6023 11 8		122
71GD6	pelēks / PA	5148746	6288 61 5		260	2371 80	gaiši pelēks 2000/ PVC	6030675	6026 98 2		122
71GD6	pelēks / PA	5148746	6288 61 5		268						
71GD6	pelēks / PA	5148746	6288 61 5		271						
71GD6	pelēks / PA	5148746	6288 61 5		274	2390	gaiši pelēks/ PVC	6024919	6023 20 7	€/gab.	122
71GD6	pelēks / PA	5148746	6288 61 5		277						
71GD6	pelēks / PA	5148746	6288 61 5		280	2392	gaiši pelēks/ PA/GF	6027132	6024 00 9		124
71GD6	pelēks / PA	5148746	6288 61 5		283						
71GD6	pelēks / PA	5148746	6288 61 5		286	2393 16	akmens pelēks 110/ PVC	6027255	6024 02 5		124
71GD6	pelēks / PA	5148746	6288 61 5		289	2393 32	akmens pelēks 110/ PVC	6027316	6024 03 3		125
71GD6	pelēks / PA	5148746	6288 61 5		292						

06 LFS\_Katalog\_2010\_Neuer\_Stand /lv / 12/07/2011 (LLEExport\_01304)

Tips	Izmērs/krāsa/cits	EAN-C.	Art.-Nr.	Cena	Lapa	Tips	Izmērs/krāsa/cits	EAN-C.	Art.-Nr.	Cena	Lapa
2410 110GR	akmens pelēks 2000 / PVC	6023295	6022 71 5	€/m	126	ASM-C5		6235278	6117 33 7	€/gab.	350
2410 110LGR	gaiši pelēks 2000 / PVC	6669257	6028 15 2		126	ASM-C5 G		6235155	6117 32 5		350
2410 170GR	akmens pelēks 2000 / PVC	6023417	6022 75 8		126	ASM-C6		6235339	6117 34 1		350
2410 170LGR	gaiši pelēks 2000 / PVC	6773893	6028 18 7		126	ASM-C6 G ASM-LWL K		6235216 6237319	6117 32 9 6117 74 0		350 350
2425 150CW	krēmbalta 300 / PVC	6782659	6168 52 3	€/gab.	125						
2425 150RW	dzidri balts 300 / PVC	6629350	6194 72 9		125	BKN120 205	/ gab. / FS	5676195	6288 00 5	306	
				€/m							
						BKN200 350	/ gab. / FS	5676201	6288 00 7	306	
2650	akmens pelēks 2000 / PVC	6362530	6020 80 1	€/m	161	BKN50 80	/ gab. / FS	5676140	6288 00 1	306	
						BKN75 125	/ gab. / FS	5676188	6288 00 3	306	
AD-90G M45		/ gab. 5469148	6258 14 1	€/gab.	348	BTA-SKS S1 SW	melns balts	5438069	6117 19 0	346	
							BTA-SKS S1 W		5483540	6117 19 1	346
ADP-B AL0.5	alumīnija lakots	6215652	6117 41 6	€/m	350						
ADP-B AL1	alumīnija lakots	6214037	6117 40 8		350	BVB125	/ gab.	5146766	6287 80 0	309	
ADP-B RW0.5	dzidri balts	6117550	6117 41 4	€/m	350						
ADP-B RW1	dzidri balts	6117499	6117 40 6		350	BVL		5147404	6288 18 0	308	
ADP-B SWGR0.5	pelēkmelna	5701286	6117 41 5	€/m	350						
ADP-B SWGR1	pelēkmelna	5701279	6117 40 7		350	CEE16E2	pelēks / PA	5148715	6288 61 2	358	
ADR-80 1 AL	alumīnija lakots / PC	6279739	6258 07 1	€/m	356	CEE32E2	pelēks / PA	5148739	6288 61 4	358	
ADR-80 1 RW	dzidri balts / PC	6043156	6258 06 9		356						
				€/100 gab.							
							CPK-C5SF UTP10	pelēks	5008569	6117 94 2	352
AH1	pelēks 12 / PVC	6014873	6178 54 0	€/100 gab.	185	CPK-C5SF UTP15	pelēks	5008620	6117 94 4	352	
							CPK-C5SF UTP2	pelēks	5081005	6117 93 8	352
AH2	pelēks 20 / PVC	6014996	6178 54 2	€/100 gab.	185	CPK-C5SF UTP7.5	pelēks	5008521	6117 94 0	352	
							CPK-C6S FTP10	pelēks	5008682	6117 95 0	353
				€/gab.							
							CPK-C6S FTP15	pelēks	5008743	6117 95 2	353
AKZ		/ St 6014750	6178 53 5	€/gab.	184	CPK-C6S FTP2	pelēks	5081401	6117 94 6	353	
							CPK-C6S FTP7.5	pelēks	5008644	6117 94 8	353
ANT-1S AL0.5	alumīnija lakots	5406235	6117 60 7	€/m	348	CST-SKS	melns / PC	5364610	6106 73 5	344	
ANT-1S RW0.5	dzidri balts	5406204	6117 60 6		348						
ANT-1S SWGR0.5	pelēkmelna	5701316	6117 61 0	€/m	348						
ANT-2D AL1	alumīnija lakots	5675181	6117 39 1		349	D2-1 110CW	krēmbalta 300 / PVC	6111619	6169 30 9	122	
ANT-2D RW1	dzidri balts	5675167	6117 38 7	€/m	349	D2-1 110RW	dzidri balts 300 / PVC	6448272	6194 03 6	122	
ANT-2D SWGR1	pelēkmelna	5675174	6117 38 9		349	D2-1 130CW	krēmbalta 300 / PVC	6111671	6169 31 7	123	
ANT-2E AL1	alumīnija lakots	5675150	6117 38 5	€/m	349	D2-1 130RW	dzidri balts 300 / PVC	6448098	6194 04 4	123	
ANT-2E RW1	dzidri balts	5675112	6117 38 1		349	D2-1 150CW	krēmbalta 300 / PVC	6781393	6169 29 5	123	
ANT-2E SWGR1	pelēkmelna	5675129	6117 38 3	€/m	349	D2-1 150RW	dzidri balts 300 / PVC	6447978	6194 05 2	123	
ANT-3E AL1	alumīnija lakots	5675235	6117 39 7		349	D2-1 170CW	krēmbalta 300 / PVC	6111732	6169 32 5	124	
ANT-3E RW1	dzidri balts	5675211	6117 39 3	€/m	349	D2-1 170RW	dzidri balts 300 / PVC	6447497	6194 06 0	124	
ANT-3E SWGR1	pelēkmelna	5675228	6117 39 5		349						
AO3VA50EL	/ Alumīnijs / EL	5157724	6287 23 3	€/m	293	D2-2 110CW	krēmbalta 300 / PVC	6111855	6169 37 6	123	
AO3VA50EL	/ Alumīnijs / EL	5157724	6287 23 3		296	D2-2 110GR	akmens pelēks 300 / PVC	6103997	6159 37 0	123	
AO3VA50RW	dzidri balts / Alumīnijs	5157687	6287 23 0	€/m	293	D2-2 110RW	dzidri balts 300 / PVC	6628636	6194 10 9	123	
AO3VA50RW	dzidri balts / Alumīnijs	5157687	6287 23 0		296	D2-2 130CW	krēmbalta 300 / PVC	6111916	6169 38 4	123	
AO3VA80EL	/ Alumīnijs / EL	5145257	6287 20 3	€/m	269	D2-2 130RW	dzidri balts 300 / PVC	6628575	6194 11 7	123	
AO3VA80EL	/ Alumīnijs / EL	5145257	6287 20 3		272	D2-2 150CW	krēmbalta 300 / PVC	6782291	6169 36 8	123	
AO3VA80EL	/ Alumīnijs / EL	5145257	6287 20 3	€/m	275	D2-2 150RW	dzidri balts 300 / PVC	6628513	6194 12 5	123	
AO3VA80EL	/ Alumīnijs / EL	5145257	6287 20 3		278	D2-2 170CW	krēmbalta 300 / PVC	6111978	6169 39 2	124	
AO3VA80EL	/ Alumīnijs / EL	5145257	6287 20 3	€/m	281	D2-2 170RW	dzidri balts 300 / PVC	6628452	6194 13 3	124	
AO3VA80EL	/ Alumīnijs / EL	5145257	6287 20 3		284	D2-2 210CW	krēmbalta 300 / PVC	6112036	6169 40 6	124	
AO3VA80EL	/ Alumīnijs / EL	5145257	6287 20 3	€/m	287	D2-2 210RW	dzidri balts 300 / PVC	6628391	6194 14 1	124	
AO3VA80EL	/ Alumīnijs / EL	5145257	6287 20 3		290	D2-3 110CW	krēmbalta 300 / PVC	6112098	6169 43 0	123	
AO3VA80EL	/ Alumīnijs / EL	5145257	6287 20 3	€/m	293	D2-3 110RW	dzidri balts 300 / PVC	6628339	6194 18 4	123	
AO3VA80EL	/ Alumīnijs / EL	5145257	6287 20 3		296	D2-3 130CW	krēmbalta 300 / PVC	6112159	6169 44 9	123	
AO3VA80EL	/ Alumīnijs / EL	5145257	6287 20 3	€/m	299	D2-3 130RW	dzidri balts 300 / PVC	6618910	6194 19 2	123	
AO3VA80EL	/ Alumīnijs / EL	5145257	6287 20 3		302	D2-3 150CW	krēmbalta 300 / PVC	6782475	6169 42 2	124	
AO3VA80RW	dzidri balts / Alumīnijs	5145240	6287 20 0	€/m	269	D2-3 150RW	dzidri balts 300 / PVC	6618859	6194 20 6	124	
AO3VA80RW	dzidri balts / Alumīnijs	5145240	6287 20 0		272	D2-3 170CW	krēmbalta 300 / PVC	6112210	6169 45 7	124	
AO3VA80RW	dzidri balts / Alumīnijs	5145240	6287 20 0	€/m	275	D2-3 170RW	dzidri balts 300 / PVC	6349814	6194 21 4	124	
AO3VA80RW	dzidri balts / Alumīnijs	5145240	6287 20 0		281						
AO3VA80RW	dzidri balts / Alumīnijs	5145240	6287 20 0	€/m	284	DAB-F	dzidri balts / gab.	5448792	6290 26 9	329	
AO3VA80RW	dzidri balts / Alumīnijs	5145240	6287 20 0		287	DAB-F	dzidri balts / gab.	5448792	6290 26 9	330	
AO3VA80RW	dzidri balts / Alumīnijs	5145240	6287 20 0	€/m	290	DAB-F	dzidri balts / gab.	5448792	6290 26 9	332	
AO3VA80RW	dzidri balts / Alumīnijs	5145240	6287 20 0		293						
AO3VA80RW	dzidri balts / Alumīnijs	5145240	6287 20 0	€/m	296						
AO3VA80RW	dzidri balts / Alumīnijs	5145240	6287 20 0		299	DMG-1RM AL0.5	alumīnija lakots	5006725	6117 29 3	351	
AO3VA80RW	dzidri balts / Alumīnijs	5145240	6287 20 0	€/m	302	DMG-1RM RW0.5	dzidri balts	6233410	6117 29 2	351	
AS-B AL0.5	alumīnija lakots	5275688	6117 62 1		€/m	346	DMG-1RM SWGR0.5	pelēkmelna	5701163	6117 29 1	351
AS-B RW0.5	dzidri balts	5275640	6117 62 0	346							
AS-B SWGR0.5	pelēkmelna	5701019	6117 62 2	€/m	346	DMG-2RM AL1	alumīnija lakots	5006961	6117 32 0	351	
AS-B2P AL1	alumīnija lakots	5275886	6117 64 5		347	DMG-2RM RW1	balts	5006947	6117 31 9	351	
AS-B2P RW1	dzidri balts	5275879	6117 64 4	€/m	347						
AS-B2P SWGR1	pelēkmelna	5701088	6117 64 3		347	DMG-2RM SWGR1	pelēkmelna	5701200	6117 31 8	351	

06 LFS\_Katalog\_2010\_Neuer\_Stand /lv /1207/2011 (LLEExport\_01304)

# Tipu saraksts

EAN numura uzbūve: valsts kods 40

ražotāja kods 1219 (art. numuriem, kas sākas ar 0: 1010)

individuālais EAN-C 5647589

Tips	Izmērs/krāsa/cits	EAN-C.	Art.-Nr.	Cena	Lapa	Tips	Izmērs/krāsa/cits	EAN-C.	Art.-Nr.	Cena	Lapa
DMS-2RM AL1	alumīnija lakots/ PC	5006886	6117 31 6	€/gab.	351	FO3VRW	dzidri balts/ Alumīnijs	5145264	6287 21 0	€/gab.	287
DMS-2RM RW1	dzidri balts/ PC	5006848	6117 31 5		351	FO3VRW	dzidri balts/ Alumīnijs	5145264	6287 21 0		290
DMS-2RM SWGR1	pelēkmeina/ PC	5701194	6117 31 4		351	FO3VRW	dzidri balts/ Alumīnijs	5145264	6287 21 0		294
						FO3VRW	dzidri balts/ Alumīnijs	5157663	6287 22 0		294
						FO3VRW	dzidri balts/ Alumīnijs	5145264	6287 21 0		297
						FO3VRW	dzidri balts/ Alumīnijs	5157663	6287 22 0		297
DMZ-AVS GN	zaišs	6239054	6117 72 4		352	FO3VRW	dzidri balts/ Alumīnijs	5145264	6287 21 0		299
DMZ-AVS RO	sarkans	6239351	6117 72 6		352	FO3VRW	dzidri balts/ Alumīnijs	5145264	6287 21 0		302
DMZ-AVS W	balts	6239474	6117 72 8		352						
DMZ-ES AVS	melns	6239658	6117 74 5		352	G-AWAG70110CW	krēmbalta 178/ Alumīnijs	5666936	6278 84 1		313
DMZ-ESMV CB	balts	6237913	6117 70 8		351	G-AWAG70110LGR	gaiši pelēks 178/ Alumīnijs	5666943	6278 84 2		313
DMZ-RR RJ11	zaišs	5677819	6117 97 2		351	G-AWAG70110RW	dzidri balts 178/ Alumīnijs	5666929	6278 84 0		313
DMZ-SC GN	zaišs	5008767	6117 95 7		351	G-AWAG70130CW	krēmbalta 198/ Alumīnijs	5666981	6278 85 1		314
DMZ-SC RO	sarkans	5008804	6117 95 8		351	G-AWAG70130LGR	gaiši pelēks 198/ Alumīnijs	5666998	6278 85 2		314
DMZ-SCHL AVS	dzeltens	6239535	6117 73 2		352	G-AWAG70130RW	dzidri balts 198/ Alumīnijs	5666974	6278 85 0		314
DMZ-STS GN	zaišs	5007562	6117 73 7		351	G-AWAG70170CW	krēmbalta 238/ Alumīnijs	5667056	6278 86 1		314
DMZ-STS RO	sarkans	5007609	6117 73 8		351	G-AWAG70170LGR	gaiši pelēks 238/ Alumīnijs	5667063	6278 86 2		314
DMZ-STS W	balts	6239597	6117 73 6		351	G-AWAG70170RW	dzidri balts 238/ Alumīnijs	5667025	6278 86 0		314
						G-AWAG70210CW	krēmbalta 278/ Alumīnijs	5667100	6278 87 1		314
DTG-2A AL1	alumīnija lakots/ PC	5696940	6119 20 6		353	G-AWAG70210LGR	gaiši pelēks 278/ Alumīnijs	5667117	6278 87 2		314
DTG-2A RW1	dzidri balts/ PC	5696896	6119 20 2		353	G-AWAG70210RW	dzidri balts 278/ Alumīnijs	5667094	6278 87 0		314
DTG-2A SWGR1	pelēkmeina/ PC	5696902	6119 20 4		353	G-AWAG90110CW	krēmbalta 178/ Alumīnijs	5667414	6279 02 1		314
DTG-2B AL1	alumīnija lakots/ PC	5696971	6119 21 2		353	G-AWAG90110LGR	gaiši pelēks 178/ Alumīnijs	5667421	6279 02 2		314
DTG-2B RW1	dzidri balts/ PC	5696957	6119 20 8		353	G-AWAG90110RW	dzidri balts 178/ Alumīnijs	5667384	6279 02 0		314
DTG-2B SWGR1	pelēkmeina/ PC	5696964	6119 21 0		353	G-AWAG90130CW	krēmbalta 198/ Alumīnijs	5667483	6279 03 1		314
DTG-2C AL1	alumīnija lakots/ PC	5697008	6119 21 8		354	G-AWAG90130LGR	gaiši pelēks 198/ Alumīnijs	5667490	6279 03 2		314
DTG-2C RW1	dzidri balts/ PC	5696988	6119 21 4		354	G-AWAG90130RW	dzidri balts 198/ Alumīnijs	5667476	6279 03 0		314
DTG-2C SWGR1	pelēkmeina/ PC	5696995	6119 21 6		354	G-AWAG90170CW	krēmbalta 238/ Alumīnijs	5667537	6279 04 1		314
DTG-2EP AL1	alumīnija lakots/ PC	5697121	6119 23 6		354	G-AWAG90170LGR	gaiši pelēks 238/ Alumīnijs	5667544	6279 04 2		314
DTG-2EP RW1	dzidri balts/ PC	5697077	6119 23 2		354	G-AWAG90170RW	dzidri balts 238/ Alumīnijs	5667520	6279 04 0		314
DTG-2EP SWGR1	pelēkmeina/ PC	5697084	6119 23 4		354	G-AWAG90210CW	krēmbalta 278/ Alumīnijs	5667605	6279 05 1		315
DTG-2F AL1	alumīnija lakots/ PC	5697039	6119 22 4		354	G-AWAG90210LGR	gaiši pelēks 278/ Alumīnijs	5667612	6279 05 2		315
DTG-2F RW1	dzidri balts/ PC	5697015	6119 22 0		354	G-AWAG90210RW	dzidri balts 278/ Alumīnijs	5667599	6279 05 0		315
DTG-2F SWGR1	pelēkmeina/ PC	5697022	6119 22 2		354	G-AWA070110CW	krēmbalta 178/ Alumīnijs	5666592	6278 80 1		312
DTG-2PA AL1	alumīnija lakots/ PC	5697060	6119 23 0		355	G-AWA070110LGR	gaiši pelēks 178/ Alumīnijs	5666608	6278 80 2		312
DTG-2PA RW1	dzidri balts/ PC	5697046	6119 22 6		355	G-AWA070110RW	dzidri balts 178/ Alumīnijs	5666585	6278 80 0		312
DTG-2PA SWGR1	pelēkmeina/ PC	5697053	6119 22 8		355	G-AWA070130CW	krēmbalta 198/ Alumīnijs	5666707	6278 81 1		312
						G-AWA070130LGR	gaiši pelēks 198/ Alumīnijs	5666714	6278 81 2		312
DTS-2A AL1	alumīnija lakots/ PC	5697183	6119 24 2		353	G-AWA070130RW	dzidri balts 198/ Alumīnijs	5666660	6278 81 0		312
DTS-2A RW1	dzidri balts/ PC	5697138	6119 23 8		353	G-AWA070170CW	krēmbalta 238/ Alumīnijs	5666783	6278 82 1		313
DTS-2A SWGR1	pelēkmeina/ PC	5697145	6119 24 0		353	G-AWA070170LGR	gaiši pelēks 238/ Alumīnijs	5666820	6278 82 0		313
DTS-2B AL1	alumīnija lakots/ PC	5697244	6119 24 8		353	G-AWA070170RW	dzidri balts 238/ Alumīnijs	5666776	6278 82 2		313
DTS-2B RW1	dzidri balts/ PC	5697190	6119 24 4		353	G-AWA070210CW	krēmbalta 278/ Alumīnijs	5666882	6278 83 1		313
DTS-2B SWGR1	pelēkmeina/ PC	5697206	6119 24 6		353	G-AWA070210LGR	gaiši pelēks 278/ Alumīnijs	5666899	6278 83 2		313
DTS-2C AL1	alumīnija lakots/ PC	5697305	6119 25 4		354	G-AWA070210RW	dzidri balts 278/ Alumīnijs	5666875	6278 83 0		313
DTS-2C RW1	dzidri balts/ PC	5697251	6119 25 0		354	G-AWA090110CW	krēmbalta 178/ Alumīnijs	5667179	6278 88 1		312
						G-AWA090110LGR	gaiši pelēks 178/ Alumīnijs	5667186	6278 88 2		312
DTS-2C SWGR1	pelēkmeina/ PC	5697268	6119 25 2		354	G-AWA090110RW	dzidri balts 178/ Alumīnijs	5667148	6278 88 0		312
						G-AWA090130CW	krēmbalta 198/ Alumīnijs	5667223	6278 89 1		313
DTS-2EP AL1	alumīnija lakots/ PC	5697497	6119 27 2		354	G-AWA090130LGR	gaiši pelēks 198/ Alumīnijs	5667230	6278 89 2		313
DTS-2EP RW1	dzidri balts/ PC	5697442	6119 26 8		354	G-AWA090130RW	dzidri balts 198/ Alumīnijs	5667216	6278 89 0		313
DTS-2EP SWGR1	pelēkmeina/ PC	5697480	6119 27 0		354	G-AWA090170CW	krēmbalta 238/ Alumīnijs	5667278	6279 00 1		313
DTS-2PA AL1	alumīnija lakots/ PC	5697435	6119 26 6		355	G-AWA090170LGR	gaiši pelēks 238/ Alumīnijs	5667285	6279 00 2		313
DTS-2PA RW1	dzidri balts/ PC	5697381	6119 26 2		355	G-AWA090170RW	dzidri balts 238/ Alumīnijs	5667261	6279 00 0		313
DTS-2PA SWGR1	pelēkmeina/ PC	5697428	6119 26 4		355	G-AWA090210CW	krēmbalta 278/ Alumīnijs	5667322	6279 01 1		313
						G-AWA090210LGR	gaiši pelēks 278/ Alumīnijs	5667353	6279 01 2		313
						G-AWA090210RW	dzidri balts 278/ Alumīnijs	5667315	6279 01 0		313
EDA45	dzeltens-zaišs 400/ Cu	5030898	6257 59 8		200						
EDA45	dzeltens-zaišs 400/ Cu	5030898	6257 59 8		204					€/m	
EDAKL	/ gab. / G	6800711	6257 60 3		200	GEK-A100213DEL	/ Alumīnijs / EL	5142379	6285 30 3		301
EDAKL	/ gab. / G	6800711	6257 60 3		204	GEK-A100213DRW	dzidri balts/ Alumīnijs / FS	5142362	6285 30 0		301
						GEK-A53100EL	alumīnija/ Alumīnijs / EL	6198252	6116 51 5		200
						GEK-A53160EL	alumīnija/ Alumīnijs / EL	6204199	6116 53 6		204
EK300CW	krēmbalta 850/ gab. / FS	5126522	6246 05 2		315	GEK-A70110EL	/ Alumīnijs / EL	5157076	6285 40 3		268
EK300RW	dzidri balts 850/ gab. / FS	5126539	6246 08 7		315	GEK-A70110RW	dzidri balts/ Alumīnijs / FS	5157069	6285 40 0		268
						GEK-A70133EL	/ Alumīnijs / EL	5140887	6284 40 3		274
FO3VEL	/ Alumīnijs / EL	5145295	6287 21 3		269	GEK-A70133RW	dzidri balts/ Alumīnijs / FS	5140870	6284 40 0		274
FO3VEL	/ Alumīnijs / EL	5145295	6287 21 3		272	GEK-A70213DEL	/ Alumīnijs / EL	5142171	6285 20 3		298
FO3VEL	/ Alumīnijs / EL	5145295	6287 21 3		275	GEK-A70213DRW	dzidri balts/ Alumīnijs / FS	5142140	6285 20 0		298
FO3VEL	/ Alumīnijs / EL	5145295	6287 21 3		278	GEK-A90110EL	/ Alumīnijs / EL	5157366	6285 50 3		271
FO3VEL	/ Alumīnijs / EL	5145295	6287 21 3		281	GEK-A90110RW	dzidri balts/ Alumīnijs / FS	5157328	6285 50 0		271
FO3VEL	/ Alumīnijs / EL	5145295	6287 21 3		284	GEK-A90133EL	/ Alumīnijs / EL	5141112	6284 50 3		277
FO3VEL	/ Alumīnijs / EL	5145295	6287 21 3		287	GEK-A90133RW	dzidri balts/ Alumīnijs / FS	5141105	6284 50 0		277
FO3VEL	/ Alumīnijs / EL	5145295	6287 21 3		290					€/gab.	
FO3VEL	/ Alumīnijs / EL	5145295	6287 21 3		294	GEK-AA100213DEL	/ Alumīnijs / EL	5142416	6285 31 3		302
FO3VEL	/ Alumīnijs / EL	5157670	6287 22 3		294	GEK-AA100213DRW	dzidri balts/ Alumīnijs / FS	5142386	6285 31 0		302
FO3VEL	/ Alumīnijs / EL	5145295	6287 21 3		297	GEK-AA53100	alumīnija/ Alumīnijs / EL	6210251	6116 61 7		202
FO3VEL	/ Alumīnijs / EL	5157670	6287 22 3		297	GEK-AA53160	alumīnija/ Alumīnijs / EL	6210558	6116 64 7		206
FO3VEL	/ Alumīnijs / EL	5145295	6287 21 3		299	GEK-AA70110EL	/ Alumīnijs / EL	5157120	6285 41 3		269
FO3VEL	/ Alumīnijs / EL	5145295	6287 21 3		302	GEK-AA70110RW	dzidri balts/ Alumīnijs / FS	5157083	6285 41 0		269
FO3VRW	dzidri balts/ Alumīnijs	5145264	6287 21 0		269	GEK-AA70133EL	/ Alumīnijs / EL	5140924	6284 41 3		275
FO3VRW	dzidri balts/ Alumīnijs	5145264	6287 21 0		272	GEK-AA70133RW	dzidri balts/ Alumīnijs / FS	5140917	6284 41 0		275
FO3VRW	dzidri balts/ Alumīnijs	5145264	6287 21 0		275					€/m	
FO3VRW	dzidri balts/ Alumīnijs	5145264	6287 21 0		278	GEK-AA70173DEL	/ Alumīnijs / EL	5156598	6285 00 3		292
FO3VRW	dzidri balts/ Alumīnijs	5145264	6287 21 0		281	GEK-AA70173DRW	dzidri balts/ Alumīnijs / FS	5156581	6285 00 0		292
FO3VRW	dzidri balts/ Alumīnijs	5145264	6287 21 0		284	GEK-AA70173EL	/ Alumīnijs / EL				

Tips	Izmērs/krāsa/cits	EAN-C.	Art.-Nr.	Cena	Lapa	Tips	Izmērs/krāsa/cits	EAN-C.	Art.-Nr.	Cena	Lapa
GEK-AA70173RW	dzidri balts / Alumīnijs / FS	5141303	6284 60 0	€/m	280	GEK-AAT90173DEL	/ Alumīnijs / EL	5157021	6285 16 3	€/gab.	297
GEK-AA70213DEL	/ Alumīnijs / EL	5142195	6285 21 3	€/gab.	280	GEK-AAT90173DRWdzidri balts / Alumīnijs / FS		5157014	6285 16 0		297
GEK-AA70213DRW	dzidri balts / Alumīnijs / FS	5142188	6285 21 0	€/m	299	GEK-AAT90173EL	/ Alumīnijs / EL	5141693	6284 76 3		285
GEK-AA90110EL	/ Alumīnijs / EL	5141754	6284 80 3	€/m	299	GEK-AAT90173RW	dzidri balts / Alumīnijs / FS	5141662	6284 76 0		285
GEK-AA90110RW	dzidri balts / Alumīnijs / FS	5141723	6284 80 0	€/gab.	286	GEK-AAT90213EL	/ Alumīnijs / EL	5142119	6284 96 3		291
GEK-AA90133EL	/ Alumīnijs / EL	5157380	6285 51 3	€/m	286	GEK-AAT90213RW	dzidri balts / Alumīnijs / FS	5142089	6284 96 0		291
GEK-AA90133RW	dzidri balts / Alumīnijs / FS	5157373	6285 51 0	€/gab.	286	GEK-AE70110EL	/ Alumīnijs / EL	5157311	6285 47 3		270
GEK-AA90133RW	dzidri balts / Alumīnijs / FS	5141150	6284 51 3	€/m	272	GEK-AE70110RW	dzidri balts / Alumīnijs / FS	5157304	6285 47 0		270
GEK-AA90133RW	dzidri balts / Alumīnijs / FS	5141129	6284 51 0	€/gab.	272	GEK-AE70133EL	/ Alumīnijs / EL	5141099	6284 47 3		276
GEK-AA90173DEL	/ Alumīnijs / EL	5156833	6285 10 3	€/m	272	GEK-AE70133RW	dzidri balts / Alumīnijs / FS	5141068	6284 47 0		276
GEK-AA90173DRW	dzidri balts / Alumīnijs / FS	5156826	6285 10 0	€/gab.	278	GEK-AE90110EL	/ Alumīnijs / EL	5157601	6285 57 3		273
GEK-AA90173EL	/ Alumīnijs / EL	5141532	6284 70 3	€/m	278	GEK-AE90110RW	dzidri balts / Alumīnijs / FS	5157564	6285 57 0		273
GEK-AA90173RW	dzidri balts / Alumīnijs / FS	5141525	6284 70 0	€/gab.	278	GEK-AE901EL	/ Alumīnijs / EL	5141297	6284 57 3		279
GEK-AA90213EL	/ Alumīnijs / EL	5141952	6284 90 3	€/m	295	GEK-AE901RW	dzidri balts / Alumīnijs / FS	5141280	6284 57 0		279
GEK-AA90213RW	dzidri balts / Alumīnijs / FS	5141945	6284 90 0	€/gab.	295	GEK-AFF100213DEL	/ Alumīnijs / EL	5142478	6285 33 3		302
GEK-AA90213RW	dzidri balts / Alumīnijs / FS	5141945	6284 90 0	€/m	283	GEK-AFF100213DRWdzidri balts / Alumīnijs / FS		5142447	6285 33 0		302
GEK-AA90213RW	dzidri balts / Alumīnijs / FS	5141945	6284 90 0	€/gab.	283	GEK-AFF53100	alumīnija / Alumīnijs / EL	6211272	6116 70 9		201
GEK-AA90213RW	dzidri balts / Alumīnijs / FS	5141945	6284 90 0	€/m	289	GEK-AFF53160	alumīnija / Alumīnijs / EL	6211395	6116 73 6		205
GEK-AA90213RW	dzidri balts / Alumīnijs / FS	5141945	6284 90 0	€/gab.	289	GEK-AFF70110EL	/ Alumīnijs / EL	5157199	6285 43 3		269
GEK-AA90213RW	dzidri balts / Alumīnijs / FS	5141945	6284 90 0	€/m	289	GEK-AFF70110RW	dzidri balts / Alumīnijs / FS	5157182	6285 43 0		269
GEK-AA90213RW	dzidri balts / Alumīnijs / FS	5141945	6284 90 0	€/gab.	293	GEK-AFF70133EL	/ Alumīnijs / EL	5140986	6284 43 3		275
GEK-AA90213RW	dzidri balts / Alumīnijs / FS	5141945	6284 90 0	€/m	293	GEK-AFF70133RW	dzidri balts / Alumīnijs / FS	5140979	6284 43 0		275
GEK-AA90213RW	dzidri balts / Alumīnijs / FS	5141945	6284 90 0	€/gab.	281	GEK-AFF70213DEL	/ Alumīnijs / EL	5142256	6285 23 3		299
GEK-AA90213RW	dzidri balts / Alumīnijs / FS	5141945	6284 90 0	€/m	281	GEK-AFF70213DRWdzidri balts / Alumīnijs / FS		5142249	6285 23 0		299
GEK-AA90213RW	dzidri balts / Alumīnijs / FS	5141945	6284 90 0	€/gab.	287	GEK-AFF90110EL	/ Alumīnijs / EL	5157489	6285 53 3		272
GEK-AA90213RW	dzidri balts / Alumīnijs / FS	5141945	6284 90 0	€/m	287	GEK-AFF90110RW	dzidri balts / Alumīnijs / FS	5157441	6285 53 0		272
GEK-AA90213RW	dzidri balts / Alumīnijs / FS	5141945	6284 90 0	€/gab.	296	GEK-AFF90133EL	/ Alumīnijs / EL	5141211	6284 53 3		278
GEK-AA90213RW	dzidri balts / Alumīnijs / FS	5141945	6284 90 0	€/m	296	GEK-AFF90133RW	dzidri balts / Alumīnijs / FS	5141181	6284 53 0		278
GEK-AA90213RW	dzidri balts / Alumīnijs / FS	5141945	6284 90 0	€/gab.	290	GEK-AFF90133RW	dzidri balts / Alumīnijs / FS	5141181	6284 53 0		278
GEK-AA90213RW	dzidri balts / Alumīnijs / FS	5141945	6284 90 0	€/m	290	GEK-AFS100213DEL	/ Alumīnijs / EL	5142430	6285 32 3		302
GEK-AA90213RW	dzidri balts / Alumīnijs / FS	5141945	6284 90 0	€/gab.	290	GEK-AFS100213DRWdzidri balts / Alumīnijs / FS		5142423	6285 32 0		302
GEK-AA90213RW	dzidri balts / Alumīnijs / FS	5141945	6284 90 0	€/m	284	GEK-AFS53100	alumīnija / Alumīnijs / EL	6210671	6116 66 8		201
GEK-AA90213RW	dzidri balts / Alumīnijs / FS	5141945	6284 90 0	€/gab.	284	GEK-AFS53160	alumīnija / Alumīnijs / EL	6210978	6116 68 5		205
GEK-AA90213RW	dzidri balts / Alumīnijs / FS	5141945	6284 90 0	€/m	303	GEK-AFS70110EL	/ Alumīnijs / EL	5157144	6285 42 3		269
GEK-AA90213RW	dzidri balts / Alumīnijs / FS	5141945	6284 90 0	€/gab.	303	GEK-AFS70110RW	dzidri balts / Alumīnijs / FS	5157137	6285 42 0		269
GEK-AA90213RW	dzidri balts / Alumīnijs / FS	5141945	6284 90 0	€/m	282	GEK-AFS70133EL	/ Alumīnijs / EL	5140948	6284 42 3		275
GEK-AA90213RW	dzidri balts / Alumīnijs / FS	5141945	6284 90 0	€/gab.	294	GEK-AFS70133RW	dzidri balts / Alumīnijs / FS	5140931	6284 42 0		275
GEK-AA90213RW	dzidri balts / Alumīnijs / FS	5141945	6284 90 0	€/m	282	GEK-AFS70213DEL	/ Alumīnijs / EL	5142232	6285 22 3		299
GEK-AA90213RW	dzidri balts / Alumīnijs / FS	5141945	6284 90 0	€/gab.	294	GEK-AFS70213DRWdzidri balts / Alumīnijs / FS		5142201	6285 22 0		299
GEK-AA90213RW	dzidri balts / Alumīnijs / FS	5141945	6284 90 0	€/m	300	GEK-AFS90110EL	/ Alumīnijs / EL	5157434	6285 52 3		272
GEK-AA90213RW	dzidri balts / Alumīnijs / FS	5141945	6284 90 0	€/gab.	300	GEK-AFS90110RW	dzidri balts / Alumīnijs / FS	5157427	6285 52 0		272
GEK-AA90213RW	dzidri balts / Alumīnijs / FS	5141945	6284 90 0	€/m	288	GEK-AFS90133EL	/ Alumīnijs / EL	5141174	6284 52 3		278
GEK-AA90213RW	dzidri balts / Alumīnijs / FS	5141945	6284 90 0	€/gab.	288	GEK-AFS90133RW	dzidri balts / Alumīnijs / FS	5141167	6284 52 0		278
GEK-AA90213RW	dzidri balts / Alumīnijs / FS	5141945	6284 90 0	€/m	285	GEK-AIS3100	alumīnija / Alumīnijs / EL	6210015	6116 57 9		201
GEK-AA90213RW	dzidri balts / Alumīnijs / FS	5141945	6284 90 0	€/gab.	297	GEK-AIS3160	alumīnija / Alumīnijs / EL	6210138	6116 59 5		205
GEK-AA90213RW	dzidri balts / Alumīnijs / FS	5141945	6284 90 0	€/m	285	GEK-AIS90110EL	/ Alumīnijs / EL	5157502	6285 54 3		272
GEK-AA90213RW	dzidri balts / Alumīnijs / FS	5141945	6284 90 0	€/gab.	297	GEK-AIS90110RW	dzidri balts / Alumīnijs / FS	5157496	6285 54 0		272
GEK-AA90213RW	dzidri balts / Alumīnijs / FS	5141945	6284 90 0	€/m	291	GEK-AIA70173DEL	/ Alumīnijs / EL	5156765	6285 04 3		294
GEK-AA90213RW	dzidri balts / Alumīnijs / FS	5141945	6284 90 0	€/gab.	291	GEK-AIA70173RW	dzidri balts / Alumīnijs / FS	5156727	6285 04 0		294
GEK-AA90213RW	dzidri balts / Alumīnijs / FS	5141945	6284 90 0	€/m	293	GEK-AIA70EL	/ Alumīnijs / EL	5157243	6285 44 3		269
GEK-AA90213RW	dzidri balts / Alumīnijs / FS	5141945	6284 90 0	€/gab.	293	GEK-AIA70RW	dzidri balts / Alumīnijs / FS	5157205	6285 44 0		269
GEK-AA90213RW	dzidri balts / Alumīnijs / FS	5141945	6284 90 0	€/m	287	GEK-AIA70RW	dzidri balts / Alumīnijs / FS	5157205	6285 44 0		269
GEK-AA90213RW	dzidri balts / Alumīnijs / FS	5141945	6284 90 0	€/gab.	287	GEK-AIA90173DEL	/ Alumīnijs / EL	5157007	6285 14 3		297
GEK-AA90213RW	dzidri balts / Alumīnijs / FS	5141945	6284 90 0	€/m	287	GEK-AIA90173DRWdzidri balts / Alumīnijs / FS		5156963	6285 14 3		297
GEK-AA90213RW	dzidri balts / Alumīnijs / FS	5141945	6284 90 0	€/gab.	281	GEK-AIS100213DEL	/ Alumīnijs / EL	5142492	6285 34 0		302
GEK-AA90213RW	dzidri balts / Alumīnijs / FS	5141945	6284 90 0	€/m	281	GEK-AIS100213DRWdzidri balts / Alumīnijs / FS		5142485	6285 34 0		302
GEK-AA90213RW	dzidri balts / Alumīnijs / FS	5141945	6284 90 0	€/gab.	296	GEK-AIS70133EL	/ Alumīnijs / EL	5141006	6284 44 3		275
GEK-AA90213RW	dzidri balts / Alumīnijs / FS	5141945	6284 90 0	€/m	296	GEK-AIS70133RW	dzidri balts / Alumīnijs / FS	5140993	6284 44 0		275
GEK-AA90213RW	dzidri balts / Alumīnijs / FS	5141945	6284 90 0	€/gab.	284	GEK-AIS70213DEL	/ Alumīnijs / EL	5142294	6285 24 3		299
GEK-AA90213RW	dzidri balts / Alumīnijs / FS	5141945	6284 90 0	€/m	284	GEK-AIS70213DRWdzidri balts / Alumīnijs / FS		5142263	6285 24 0		299
GEK-AA90213RW	dzidri balts / Alumīnijs / FS	5141945	6284 90 0	€/gab.	290	GEK-AIS90133EL	/ Alumīnijs / EL	5141235	6284 54 3		278
GEK-AA90213RW	dzidri balts / Alumīnijs / FS	5141945	6284 90 0	€/m	290	GEK-AIS90133RW	dzidri balts / Alumīnijs / FS	5141228	6284 54 0		278
GEK-AA90213RW	dzidri balts / Alumīnijs / FS	5141945	6284 90 0	€/gab.	293	GEK-AKU45	/ gab.	6211456	6116 75 2		200
GEK-AA90213RW	dzidri balts / Alumīnijs / FS	5141945	6284 90 0	€/m	293	GEK-AKU45	/ gab.	6211456	6116 75 2		204
GEK-AA90213RW	dzidri balts / Alumīnijs / FS	5141945	6284 90 0	€/gab.	281	GEK-AOT45	alumīnija / Alumīnijs / EL	6202034	6116 55 8	€/m	200
GEK-AA90213RW	dzidri balts / Alumīnijs / FS	5141945	6284 90 0	€/m	287	GEK-AOT45	alumīnija / Alumīnijs / EL	6202034	6116 55 8	€/gab.	204
GEK-AA90213RW	dzidri balts / Alumīnijs / FS	5141945	6284 90 0	€/gab.	296	GEK-AT100213DEL	/ Alumīnijs / EL	5142539	6285 36 3		303
GEK-AA90213RW	dzidri balts / Alumīnijs / FS	5141945	6284 90 0	€/m	296	GEK-AT100213DRWdzidri balts / Alumīnijs / FS		5142508	6285 36 0		303
GEK-AA90213RW	dzidri balts / Alumīnijs / FS	5141945	6284 90 0	€/gab.	284	GEK-AT70110EL	/ Alumīnijs / EL	5157267	6285 46 3		270
GEK-AA90213RW	dzidri balts / Alumīnijs / FS	5141945	6284 90 0	€/m	284	GEK-AT70110RW	dzidri balts / Alumīnijs / FS	5157250	6285 46 0		270
GEK-AA90213RW	dzidri balts / Alumīnijs / FS	5141945	6284 90 0	€/gab.	290	GEK-AT70133EL	/ Alumīnijs / EL	5141051	6284 46 3		276
GEK-AA90213RW	dzidri balts / Alumīnijs / FS	5141945	6284 90 0	€/m	290	GEK-AT70133RW	dzidri balts / Alumīnijs / FS	5141044	6284 46 0		276
GEK-AA90213RW	dzidri balts / Alumīnijs / FS	5141945	6284 90 0	€/gab.	281	GEK-AT70213DEL	/ Alumīnijs / EL	5142317	6285 26 3		300
GEK-AA90213RW	dzidri balts / Alumīnijs / FS	5141945	6284 90 0	€/m	281	GEK-AT70213DRWdzidri balts / Alumīnijs / FS		5142300	6285 26 0		300
GEK-AA90213RW	dzidri balts / Alumīnijs / FS	5141945	6284 90 0	€/gab.	287	GEK-AT90110EL	/ Alumīnijs / EL	5157557	6285 56 3		273
GEK-AA90213RW	dzidri balts / Alumīnijs / FS	5141945	6284 90 0	€/m	287	GEK-AT90110RW	dzidri balts / Alumīnijs / FS	5157540	6285 56 0		273
GEK-AA90213RW	dzidri balts / Alumīnijs / FS	5141945	6284 90 0	€/gab.	284	GEK-AT90133EL	/ Alumīnijs / EL	5141273	6284 56 3		279
GEK-AA90213RW	dzidri balts / Alumīnijs / FS	5141945	6284 90 0	€/m</							

# Tipu saraksts

EAN numura uzbūve: valsts kods 40

ražotāja kods 1219 (art. numuriem, kas sākas ar 0: 1010)

individuālais EAN-C 5647589

Tips	Izmērs/krāsa/cits	EAN-C.	Art.-Nr.	Cena	Lapa	Tips	Izmērs/krāsa/cits	EAN-C.	Art.-Nr.	Cena	Lapa	
GEK-KA53160	alumīnija / PVC	6184811	6116 28 5	€/gab.	206	GK-E70130LGR	gaiši pelēks / PVC	5656975	6274 57 2	€/gab.	215	
GEK-KA53160-3	dzidri balts / PVC	5428695	6116 26 1		195	GK-E70130RW	dzidri balts / PVC	5656951	6274 57 0		215	
GEK-KAS53100	dzidri balts / PVC	6192915	6116 27 2		189	GK-E70170CW	krēmbalta / PVC	5657279	6274 77 1		218	
GEK-KAS53160	dzidri balts / PVC	6193158	6116 29 4		192	GK-E70170GR	akmens pelēks / PVC	5657293	6274 77 6		218	
GEK-KAS53160-3	dzidri balts / PVC	5391678	6116 26 3		195	GK-E70170LGR	gaiši pelēks / PVC	5657286	6274 77 2		218	
GEK-KE53160-3	dzidri balts / PVC	5391685	6116 40 3		195	GK-E70170RW	dzidri balts / PVC	5657262	6274 77 0		218	
GEK-KEL53100	alumīnija / PVC	6184095	6116 30 7		202	GK-F70110CW	krēmbalta / PVC	5656463	6274 32 1		211	
GEK-KEL53160	dzidri balts / PVC	6441136	6116 32 9		193	GK-F70110GR	akmens pelēks / PVC	5656500	6274 32 6		211	
GEK-KEL53160	alumīnija / PVC	6184873	6116 33 4		206	GK-F70110LGR	gaiši pelēks / PVC	5656494	6274 32 2		211	
GEK-KER53100	dzidri balts / PVC	6616930	6116 35 3		190	GK-F70110RW	dzidri balts / PVC	5655664	6274 32 0		211	
GEK-KER53100	alumīnija / PVC	6184217	6116 35 8		203	GK-F70130CW	krēmbalta / PVC	5656845	6274 52 1		214	
GEK-KER53160	dzidri balts / PVC	6441198	6116 38 8		193	GK-F70130GR	akmens pelēks / PVC	5656869	6274 52 6		214	
GEK-KER53160	alumīnija / PVC	6184934	6116 39 3		207	GK-F70130LGR	gaiši pelēks / PVC	5656852	6274 52 2		214	
GEK-KF53160-3	dzidri balts / PVC	5391692	6116 49 3		194	GK-F70130RW	dzidri balts / PVC	5656838	6274 52 0		214	
GEK-KFF53100	dzidri balts / PVC	6184514	6116 46 4		188	GK-F70170CW	krēmbalta / PVC	5657156	6274 72 1		217	
GEK-KFF53160	dzidri balts / PVC	6191239	6116 48 0		191	GK-F70170GR	akmens pelēks / PVC	5657170	6274 72 6		217	
GEK-KFS53100	dzidri balts / PVC	6184330	6116 41 8		188	GK-F70170LGR	gaiši pelēks / PVC	5657163	6274 72 2		217	
GEK-KFS53160	dzidri balts / PVC	6184996	6116 43 4		191	GK-F70170RW	dzidri balts / PVC	5657149	6274 72 0		217	
GEK-KI53100	dzidri balts / PVC	6709038	6116 20 5		189							
GEK-KI53100	alumīnija / PVC	6183678	6116 21 0		201	GK-I70110CW	krēmbalta / PVC	5656524	6274 34 1		212	
GEK-KI53160	dzidri balts / PVC	6440955	6116 22 1	192	GK-I70110GR	akmens pelēks / PVC	5656562	6274 34 6	212			
GEK-KI53160	alumīnija / PVC	6184699	6116 22 6	205	GK-I70110LGR	gaiši pelēks / PVC	5656555	6274 34 2	212			
GEK-KI53160-3	dzidri balts / PVC	5428688	6116 20 1	194	GK-I70110RW	dzidri balts / PVC	5656517	6274 34 0	212			
GEK-KIS53100	dzidri balts / PVC	6192793	6116 21 3	189	GK-I70130CW	krēmbalta / PVC	5656883	6274 54 1	215			
GEK-KIS53160	dzidri balts / PVC	6192977	6116 24 8	192	GK-I70130GR	akmens pelēks / PVC	5656906	6274 54 6	215			
GEK-KIS53160-3	dzidri balts / PVC	5391661	6116 20 3	195	GK-I70130LGR	gaiši pelēks / PVC	5656890	6274 54 2	215			
GEK-KK53100	dzidri balts / PVC	5391883	6116 49 5	190	GK-I70130RW	dzidri balts / PVC	5656876	6274 54 0	215			
GEK-KK53100	alumīnija / PVC	5391890	6116 49 6	202	GK-I70170CW	krēmbalta / PVC	5657194	6274 74 1	218			
GEK-KK53160	dzidri balts / PVC	5392088	6116 49 8	193	GK-I70170GR	akmens pelēks / PVC	5657217	6274 74 6	218			
GEK-KK53160	alumīnija / PVC	5392095	6116 49 9	206	GK-I70170LGR	gaiši pelēks / PVC	5657200	6274 74 2	218			
				€/m		GK-I70170RW	dzidri balts / PVC	5657187	6274 74 0	218		
GEK-KOT45	dzidri balts 2000 / PVC	6708970	6116 10 8	188								
GEK-KOT45	dzidri balts 2000 / PVC	6708970	6116 10 8	191	GK-KUP	gaiši pelēks / ABS/ASA	5657033	6274 65 0	210			
GEK-KOT45	dzidri balts 2000 / PVC	6708970	6116 10 8	194	GK-KUP	gaiši pelēks / ABS/ASA	5657033	6274 65 0	213			
				€/gab.		GK-KUP	gaiši pelēks / ABS/ASA	5657033	6274 65 0	216		
GEK-KS45	dzidri balts / PVC	6441259	6116 15 0	188								
GEK-KS45	dzidri balts / PVC	6441259	6116 15 0	191	GK-OTGACW	krēmbalta / PVC	5657347	6274 79 1	211			
GEK-KS45	alumīnija / PVC	6183739	6116 15 4	201	GK-OTGACW	krēmbalta / PVC	5657347	6274 79 1	214			
GEK-KS45	alumīnija / PVC	6183739	6116 15 4	205	GK-OTGACW	krēmbalta / PVC	5657347	6274 79 1	217			
GEK-KS45-3	dzidri balts / PVC	5391647	6116 16 3	194	GK-OTGACW	krēmbalta / PVC	5657347	6274 79 1	224			
GEK-KT53160-3	dzidri balts / PVC	5391654	6116 19 3	195	GK-OTGACW	krēmbalta / PVC	5657347	6274 79 1	229			
GEK-KTF53100	dzidri balts / PVC	5391982	6116 18 0	190	GK-OTGACW	krēmbalta / PVC	5657347	6274 79 1	234			
GEK-KTF53100	alumīnija / PVC	5392026	6116 18 1	202	GK-OTGACW	krēmbalta / PVC	5657347	6274 79 1	240			
GEK-KTF53160	dzidri balts / PVC	5392033	6116 18 4	193	GK-OTGACW	krēmbalta / PVC	5657347	6274 79 1	245			
GEK-KTF53160	alumīnija / PVC	5392040	6116 18 5	206	GK-OTGACW	krēmbalta / PVC	5657347	6274 79 1	256			
GEK-KTS53100	dzidri balts / PVC	5391913	6116 16 7	190	GK-OTGACW	krēmbalta / PVC	5657347	6274 79 1	262			
GEK-KTS53100	alumīnija / PVC	5391920	6116 16 9	202	GK-OTGAGR	akmens pelēks / PVC	5657361	6274 79 6	211			
GEK-KTS53160	dzidri balts / PVC	5391968	6116 17 2	193	GK-OTGAGR	akmens pelēks / PVC	5657361	6274 79 6	214			
GEK-KTS53160	alumīnija / PVC	5391975	6116 17 4	206	GK-OTGAGR	akmens pelēks / PVC	5657361	6274 79 6	217			
GEK-LZ		5427650	6270 67 0	196	GK-OTGALGR	gaiši pelēks / PVC	5657354	6274 79 2	211			
				€/m		GK-OTGALGR	gaiši pelēks / PVC	5657354	6274 79 2	214		
						GK-OTGALGR	gaiši pelēks / PVC	5657354	6274 79 2	217		
GK-70110CW	krēmbalta 2000 / PVC	5656333	6274 30 1	210	GK-OTGALGR	gaiši pelēks / PVC	5657354	6274 79 2	224			
GK-70110GR	akmens pelēks 2000 / PVC	5656371	6274 30 6	210	GK-OTGALGR	gaiši pelēks / PVC	5657354	6274 79 2	229			
GK-70110LGR	gaiši pelēks 2000 / PVC	5656340	6274 30 2	210	GK-OTGALGR	gaiši pelēks / PVC	5657354	6274 79 2	234			
GK-70110RW	dzidri balts 2000 / PVC	5655473	6274 30 0	210	GK-OTGALGR	gaiši pelēks / PVC	5657354	6274 79 2	240			
GK-70130CW	krēmbalta 2000 / PVC	5656746	6274 50 1	213	GK-OTGALGR	gaiši pelēks / PVC	5657354	6274 79 2	245			
GK-70130GR	akmens pelēks 2000 / PVC	5656760	6274 50 6	213	GK-OTGALGR	gaiši pelēks / PVC	5657354	6274 79 2	256			
GK-70130LGR	gaiši pelēks 2000 / PVC	5656753	6274 50 2	213	GK-OTGALGR	gaiši pelēks / PVC	5657354	6274 79 2	262			
GK-70130RW	dzidri balts 2000 / PVC	5656739	6274 50 0	213	GK-OTGARW	dzidri balts / PVC	5657309	6274 79 0	211			
GK-70170CW	krēmbalta 2000 / PVC	5657057	6274 70 1	216	GK-OTGARW	dzidri balts / PVC	5657309	6274 79 0	214			
GK-70170GR	akmens pelēks 2000 / PVC	5657071	6274 70 6	216	GK-OTGARW	dzidri balts / PVC	5657309	6274 79 0	217			
GK-70170LGR	gaiši pelēks 2000 / PVC	5657064	6274 70 2	216	GK-OTGARW	dzidri balts / PVC	5657309	6274 79 0	224			
GK-70170RW	dzidri balts 2000 / PVC	5657040	6274 70 0	216	GK-OTGARW	dzidri balts / PVC	5657309	6274 79 0	229			
				€/gab.		GK-OTGARW	dzidri balts / PVC	5657309	6274 79 0	234		
						GK-OTGARW	dzidri balts / PVC	5657309	6274 79 0	240		
GK-A70110CW	krēmbalta / PVC	5656432	6274 31 1	211	GK-OTGARW	dzidri balts / PVC	5657309	6274 79 0	245			
GK-A70110GR	akmens pelēks / PVC	5656456	6274 31 6	211	GK-OTGARW	dzidri balts / PVC	5657309	6274 79 0	256			
GK-A70110LGR	gaiši pelēks / PVC	5656449	6274 31 2	211	GK-OTGARW	dzidri balts / PVC	5657309	6274 79 0	262			
GK-A70110RW	dzidri balts / PVC	5656401	6274 31 0	211								
GK-A70130CW	krēmbalta / PVC	5656807	6274 51 1	214	GK-OTGCW	krēmbalta 2000 / PVC	5666417	6278 68 1	210			
GK-A70130GR	akmens pelēks / PVC	5656821	6274 51 6	214	GK-OTGCW	krēmbalta 2000 / PVC	5666417	6278 68 1	213			
GK-A70130LGR	gaiši pelēks / PVC	5656814	6274 51 2	214	GK-OTGCW	krēmbalta 2000 / PVC	5666417	6278 68 1	216			
GK-A70130RW	dzidri balts / PVC	5656791	6274 51 0	214	GK-OTGCW	krēmbalta 2000 / PVC	5666417	6278 68 1	223			
GK-A70170CW	krēmbalta / PVC	5657118	6274 71 1	217	GK-OTGCW	krēmbalta 2000 / PVC	5666417	6278 68 1	228			
GK-A70170GR	akmens pelēks / PVC	5657132	6274 71 6	217	GK-OTGCW	krēmbalta 2000 / PVC	5666417	6278 68 1	233			
GK-A70170LGR	gaiši pelēks / PVC	5657125	6274 71 2	217	GK-OTGCW	krēmbalta 2000 / PVC	5666417	6278 68 1	239			
GK-A70170RW	dzidri balts / PVC	5657101	6274 71 0	217	GK-OTGCW	krēmbalta 2000 / PVC	5666417	6278 68 1	244			
						GK-OTGCW	krēmbalta 2000 / PVC	5666417	6278 68 1	255		
GK-E70110CW	krēmbalta / PVC	5656647	6274 37 1	212	GK-OTGCW	krēmbalta 2000 / PVC	5666417	6278 68 1	261			
GK-E70110GR	akmens pelēks / PVC	5656685	6274 37 6	212								
GK-E70110LGR	gaiši pelēks / PVC	5656678	6274 37 2	212	GK-OTGFCW	krēmbalta / PVC	5656708	6274 49 1	211			
GK-E70110RW	dzidri balts / PVC	5656630	6274 37 0	212	GK-OTGFCW	krēmbalta / PVC	5656708	6274 49 1	214			
GK-E70130CW	krēmbalta / PVC	5656968	6274 57 1	215	GK-OTGFCW	krēmbalta / PVC	5656708	6274 49 1	217			
GK-E70130GR	akmens pelēks / PVC	5656982	6274 57 6	215	GK-OTGFCW	krēmbalta / PVC	5656708	6274 49 1	225			



# Tipu saraksts

EAN numura uzbūve: valsts kods 40

ražotāja kods 1219 (art. numuriem, kas sākas ar 0: 1010)

individuālais EAN-C 5647589

Tips	Izmērs/krāsa/cits	EAN-C.	Art.-Nr.	Cena	Lapa	Tips	Izmērs/krāsa/cits	EAN-C.	Art.-Nr.	Cena	Lapa
GK-TW70	2000 / PVC	5658122	6274 90 0	€/m	215	GS-AA70210LGR	gaiši pelēks / gab. / FS	5663836	6278 01 2	€/gab.	256
GK-TW70	2000 / PVC	5658122	6274 90 0		218	GS-AA70210RW	dzidri balts / gab. / FS	5663812	6278 01 0		256
				€/gab.		GS-AA90130CW	krēmbalta / gab. / FS	5661917	6277 51 1	234	
							GS-AA90130LGR	gaiši pelēks / gab. / FS	5661924	6277 51 2	234
G-KWAG70110CW	krēmbalta 178 / ABS/ASA	5657729	6274 85 1	311	GS-AA90130RW	dzidri balts / gab. / FS	5661900	6277 51 0	234		
G-KWAG70110GR	krēmbalta 178 / ABS/ASA	5657774	6274 85 6	311	GS-AA90170CW	krēmbalta / gab. / FS	5663416	6277 91 1	245		
G-KWAG70110LGR	gaiši pelēks 178 / ABS/ASA	5657767	6274 85 2	311	GS-AA90170LGR	gaiši pelēks / gab. / FS	5663423	6277 91 2	245		
G-KWAG70110RW	dzidri balts 178 / ABS/ASA	5657712	6274 85 0	311	GS-AA90170RW	dzidri balts / gab. / FS	5663409	6277 91 0	245		
G-KWAG70130CW	krēmbalta 198 / ABS/ASA	5657828	6274 86 1	311	GS-AA90210CW	krēmbalta / gab. / FS	5664185	6278 11 1	256		
G-KWAG70130GR	krēmbalta 198 / ABS/ASA	5657842	6274 86 6	311	GS-AA90210LGR	gaiši pelēks / gab. / FS	5664192	6278 11 2	256		
G-KWAG70130LGR	gaiši pelēks 198 / ABS/ASA	5657835	6274 86 2	311	GS-AA90210RW	dzidri balts / gab. / FS	5664178	6278 11 0	256		
G-KWAG70130RW	dzidri balts 198 / ABS/ASA	5657781	6274 86 0	311	GS-AFF70130CW	krēmbalta / gab. / FS	5661481	6277 43 1	235		
G-KWAG70170CW	krēmbalta 238 / ABS/ASA	5657897	6274 87 1	311	GS-AFF70130LGR	gaiši pelēks / gab. / FS	5661498	6277 43 2	235		
G-KWAG70170GR	krēmbalta 238 / ABS/ASA	5657941	6274 87 6	311	GS-AFF70130RW	dzidri balts / gab. / FS	5661443	6277 43 0	235		
G-KWAG70170LGR	gaiši pelēks 238 / ABS/ASA	5657903	6274 87 2	311	GS-AFF70170CW	krēmbalta / gab. / FS	5663157	6277 83 1	246		
G-KWAG70170RW	dzidri balts 238 / ABS/ASA	5657880	6274 87 0	311	GS-AFF70170LGR	gaiši pelēks / gab. / FS	5663164	6277 83 2	246		
G-KWAG70210CW	krēmbalta 278 / ABS/ASA	5657965	6274 88 1	312	GS-AFF70170RW	dzidri balts / gab. / FS	5663140	6277 83 0	246		
G-KWAG70210LGR	gaiši pelēks 278 / ABS/ASA	5658009	6274 88 2	312	GS-AFF70210CW	krēmbalta / gab. / FS	5663911	6278 03 1	257		
G-KWAG70210RW	dzidri balts 278 / ABS/ASA	5657958	6274 88 0	312	GS-AFF70210LGR	gaiši pelēks / gab. / FS	5663928	6278 03 2	257		
G-KWAG90110CW	krēmbalta 178 / ABS/ASA	5658481	6274 95 1	311	GS-AFF70210RW	dzidri balts / gab. / FS	5663904	6278 03 0	257		
G-KWAG90110LGR	gaiši pelēks 178 / ABS/ASA	5658498	6274 95 2	311	GS-AFF90130CW	krēmbalta / gab. / FS	5662037	6277 53 1	235		
G-KWAG90110RW	dzidri balts 178 / ABS/ASA	5658443	6274 95 0	311	GS-AFF90130LGR	gaiši pelēks / gab. / FS	5662044	6277 53 2	235		
G-KWAG90130CW	krēmbalta 198 / ABS/ASA	5658559	6274 96 1	311	GS-AFF90130RW	dzidri balts / gab. / FS	5662020	6277 53 0	235		
G-KWAG90130LGR	gaiši pelēks 198 / ABS/ASA	5658566	6274 96 2	311	GS-AFF90170CW	krēmbalta / gab. / FS	5663546	6277 93 1	246		
G-KWAG90130RW	dzidri balts 198 / ABS/ASA	5658542	6274 96 0	311	GS-AFF90170LGR	gaiši pelēks / gab. / FS	5663577	6277 93 2	246		
G-KWAG90170CW	krēmbalta 238 / ABS/ASA	5658597	6274 97 1	312	GS-AFF90170RW	dzidri balts / gab. / FS	5663539	6277 93 0	246		
G-KWAG90170LGR	gaiši pelēks 238 / ABS/ASA	5658603	6274 97 2	312	GS-AFF90210CW	krēmbalta / gab. / FS	5664307	6278 13 1	257		
G-KWAG90170RW	dzidri balts 238 / ABS/ASA	5658580	6274 97 0	312	GS-AFF90210LGR	gaiši pelēks / gab. / FS	5664314	6278 13 2	257		
G-KWAG90210CW	krēmbalta 278 / ABS/ASA	5658665	6274 98 1	312	GS-AFF90210RW	dzidri balts / gab. / FS	5664260	6278 13 0	257		
G-KWAG90210LGR	gaiši pelēks 278 / ABS/ASA	5658672	6274 98 2	312	GS-AFS70130CW	krēmbalta / gab. / FS	5661382	6277 42 1	234		
G-KWAG90210RW	dzidri balts 278 / ABS/ASA	5658627	6274 98 0	312	GS-AFS70130LGR	gaiši pelēks / gab. / FS	5661429	6277 42 2	234		
G-KWA070110CW	krēmbalta 178 / ABS/ASA	5657415	6274 81 1	309	GS-AFS70130RW	dzidri balts / gab. / FS	5661375	6277 42 0	234		
G-KWA070110GR	krēmbalta 178 / ABS/ASA	5657460	6274 81 6	309	GS-AFS70170CW	krēmbalta / gab. / FS	5663119	6277 82 1	245		
G-KWA070110LGR	gaiši pelēks 178 / ABS/ASA	5657422	6274 81 2	309	GS-AFS70170LGR	gaiši pelēks / gab. / FS	5663126	6277 82 2	245		
G-KWA070110RW	dzidri balts 178 / ABS/ASA	5657408	6274 81 0	309	GS-AFS70170RW	dzidri balts / gab. / FS	5663102	6277 82 0	245		
G-KWA070130CW	krēmbalta 198 / ABS/ASA	5657484	6274 82 1	310	GS-AFS70210CW	krēmbalta / gab. / FS	5663874	6278 02 1	256		
G-KWA070130GR	krēmbalta 198 / ABS/ASA	5657538	6274 82 6	310	GS-AFS70210LGR	gaiši pelēks / gab. / FS	5663881	6278 02 2	256		
G-KWA070130LGR	gaiši pelēks 198 / ABS/ASA	5657521	6274 82 2	310	GS-AFS70210RW	dzidri balts / gab. / FS	5663867	6278 02 0	256		
G-KWA070130RW	dzidri balts 198 / ABS/ASA	5657477	6274 82 0	310	GS-AFS90130CW	krēmbalta / gab. / FS	5661993	6277 52 1	234		
G-KWA070170CW	krēmbalta 238 / ABS/ASA	5657583	6274 83 1	310	GS-AFS90130LGR	gaiši pelēks / gab. / FS	5662006	6277 52 2	234		
G-KWA070170GR	krēmbalta 238 / ABS/ASA	5657606	6274 83 6	310	GS-AFS90130RW	dzidri balts / gab. / FS	5661986	6277 52 0	234		
G-KWA070170LGR	gaiši pelēks 238 / ABS/ASA	5657590	6274 83 2	310	GS-AFS90170CW	krēmbalta / gab. / FS	5663485	6277 92 1	245		
G-KWA070170RW	dzidri balts 238 / ABS/ASA	5657545	6274 83 0	310	GS-AFS90170LGR	gaiši pelēks / gab. / FS	5663515	6277 92 2	245		
G-KWA070210CW	krēmbalta 278 / ABS/ASA	5657651	6274 84 1	310	GS-AFS90170RW	dzidri balts / gab. / FS	5663478	6277 92 0	245		
G-KWA070210LGR	gaiši pelēks 278 / ABS/ASA	5657668	6274 84 2	310	GS-AFS90210CW	krēmbalta / gab. / FS	5664239	6278 12 1	256		
G-KWA070210RW	dzidri balts 278 / ABS/ASA	5657644	6274 84 0	310	GS-AFS90210LGR	gaiši pelēks / gab. / FS	5664246	6278 12 2	256		
G-KWA090110CW	krēmbalta 178 / ABS/ASA	5658146	6274 91 1	310	GS-AFS90210RW	dzidri balts / gab. / FS	5664222	6278 12 0	256		
G-KWA090110LGR	gaiši pelēks 178 / ABS/ASA	5658184	6274 91 2	310	GS-AI70130CW	krēmbalta / gab. / FS	5661566	6277 44 1	235		
G-KWA090110RW	dzidri balts 178 / ABS/ASA	5658139	6274 91 0	310	GS-AI70130LGR	gaiši pelēks / gab. / FS	5661603	6277 44 2	235		
G-KWA090130CW	krēmbalta 198 / ABS/ASA	5658245	6274 92 1	310	GS-AI70130RW	dzidri balts / gab. / FS	5661559	6277 44 0	235		
G-KWA090130LGR	gaiši pelēks 198 / ABS/ASA	5658252	6274 92 2	310	GS-AI70170CW	krēmbalta / gab. / FS	5663201	6277 84 1	246		
G-KWA090130RW	dzidri balts 198 / ABS/ASA	5658207	6274 92 0	310	GS-AI70170LGR	gaiši pelēks / gab. / FS	5663218	6277 84 2	246		
G-KWA090170CW	krēmbalta 238 / ABS/ASA	5658313	6274 93 1	310	GS-AI70170RW	dzidri balts / gab. / FS	5663195	6277 84 0	246		
G-KWA090170LGR	gaiši pelēks 238 / ABS/ASA	5658320	6274 93 2	310	GS-AI70210CW	krēmbalta / gab. / FS	5663966	6278 05 1	257		
G-KWA090170RW	dzidri balts 238 / ABS/ASA	5658306	6274 93 0	310	GS-AI70210LGR	gaiši pelēks / gab. / FS	5663973	6278 05 2	257		
G-KWA090210CW	krēmbalta 278 / ABS/ASA	5658382	6274 94 1	311	GS-AI70210RW	dzidri balts / gab. / FS	5663959	6278 05 0	257		
G-KWA090210LGR	gaiši pelēks 278 / ABS/ASA	5658429	6274 94 2	311	GS-AI90130CW	krēmbalta / gab. / FS	5662082	6277 54 1	235		
G-KWA090210RW	dzidri balts 278 / ABS/ASA	5658375	6274 94 0	311	GS-AI90130LGR	gaiši pelēks / gab. / FS	5662099	6277 54 2	235		
				€/m		GS-AI90130RW	dzidri balts / gab. / FS	5662075	6277 54 0	235	
							GS-AI90170CW	krēmbalta / gab. / FS	5663638	6277 94 1	246
GS-A70130CW	krēmbalta 2000 / gab. / FS	5661146	6277 40 1	232	GS-AI90170LGR	gaiši pelēks / gab. / FS	5663645	6277 94 2	246		
GS-A70130LGR	gaiši pelēks 2000 / gab. / FS	5661184	6277 40 2	232	GS-AI90170RW	dzidri balts / gab. / FS	5663607	6277 94 0	246		
GS-A70130RW	dzidri balts 2000 / gab. / FS	5661139	6277 40 0	232	GS-AI90210CW	krēmbalta / gab. / FS	5664383	6278 14 1	257		
GS-A70170CW	krēmbalta 2000 / gab. / FS	5662976	6277 80 1	243	GS-AI90210LGR	gaiši pelēks / gab. / FS	5664420	6278 14 2	257		
GS-A70170LGR	gaiši pelēks 2000 / gab. / FS	5662983	6277 80 2	243	GS-AI90210RW	dzidri balts / gab. / FS	5664376	6278 14 0	257		
GS-A70170RW	dzidri balts 2000 / gab. / FS	5662945	6277 80 0	243	GS-AT70130CW	krēmbalta / gab. / FS	5661672	6277 46 1	236		
GS-A70210CW	krēmbalta 2000 / gab. / FS	5663751	6278 00 1	254	GS-AT70130LGR	gaiši pelēks / gab. / FS	5661689	6277 46 2	236		
GS-A70210LGR	gaiši pelēks 2000 / gab. / FS	5663768	6278 00 2	254	GS-AT70130RW	dzidri balts / gab. / FS	5661665	6277 46 0	236		
GS-A70210RW	dzidri balts 2000 / gab. / FS	5663744	6278 00 0	254	GS-AT70170CW	krēmbalta / gab. / FS	5663270	6277 86 1	247		
GS-A90130CW	krēmbalta 2000 / gab. / FS	5661788	6277 50 1	232	GS-AT70170LGR	gaiši pelēks / gab. / FS	5663287	6277 86 2	247		
GS-A90130LGR	gaiši pelēks 2000 / gab. / FS	5661795	6277 50 2	232	GS-AT70170RW	dzidri balts / gab. / FS	5663249	6277 86 0	247		
GS-A90130RW	dzidri balts 2000 / gab. / FS	5661740	6277 50 0	232	GS-AT70210CW	krēmbalta / gab. / FS	5664017	6278 06 1	258		
GS-A90170CW	krēmbalta 2000 / gab. / FS	5663324	6277 90 1	243	GS-AT70210LGR	gaiši pelēks / gab. / FS	5664024	6278 06 2	258		
GS-A90170LGR	gaiši pelēks 2000 / gab. / FS	5663331	6277 90 2	243	GS-AT70210RW	dzidri balts / gab. / FS	5664000	6278 06 0	258		
GS-A90170RW	dzidri balts 2000 / gab. / FS	5663317	6277 90 0	243	GS-AT90130CW	krēmbalta / gab. / FS	5662136	6277 56 1	236		
GS-A90210CW	krēmbalta 2000 / gab. / FS	5664116	6278 10 1	254	GS-AT90130LGR	gaiši pelēks / gab. / FS	5662143	6277 56 2	236		
GS-A90210LGR	gaiši pelēks 2000 / gab. / FS	5664123	6278 10 2	254	GS-AT90130RW	dzidri balts / gab. / FS	5662129	6277 56 0	236		
GS-A90210RW	dzidri balts 2000 / gab. / FS	5664109	6278 10 0	254	GS-AT90170CW	krēmbalta / gab. / FS	5663706	6277 96 1	247		
				€/gab.		GS-AT90170LGR	gaiši pelēks / gab. / FS	5663713	6277 96 2	247	
							GS-AT90170RW	dzidri balts / gab. / FS	5663690	6277 96 0	247
GS-AA70130CW	krēmbalta / gab. / FS	5661306	6277 41 1	234	GS-AT90210CW	krēmbalta / gab. / FS	5664499	6278 16 1	258		
GS-AA70130LGR	gaiši pelēks / gab. / FS	5661313	6277 41 2	234	GS-AT90210LGR	gaiši pelēks / gab. / FS	5664505	6278 16 2	258		
GS-AA70130RW	dzidri balts / gab. / FS	5661269	6277 41 0	234	GS-AT90210RW	dzidri balts / gab. / FS	5664482	6278 16 0	258		
GS-AA70170CW	krēmbalta / gab. / FS	5663041	6277 81 1	245							
GS-AA70170LGR	gaiši pelēks / gab. / FS	566									

Tips	Izmērs/krāsa/cits	EAN-C.	Art.-Nr.	Cena	Lapa	Tips	Izmērs/krāsa/cits	EAN-C.	Art.-Nr.	Cena	Lapa
GS-D70170LGR	gaiši pelēks 2000 / gab. / FS	5664680	6278 20 2	€/m	249	GS-E70170LGR	gaiši pelēks / gab. / FS	5662488	6277 67 2	€/gab.	247
GS-D70170RW	dzidri balts 2000 / gab. / FS	5664666	6278 20 0		249	GS-E70170LGR	gaiši pelēks / gab. / FS	5662488	6277 67 2		252
GS-D70210CW	dzidri balts 2000 / gab. / FS	5665557	6278 40 0	260	GS-E70170RW	dzidri balts / gab. / FS	5662464	6277 67 0	242		
GS-D70210LGR	gaiši pelēks 2000 / gab. / FS	5665571	6278 40 2	260	GS-E70170RW	dzidri balts / gab. / FS	5662464	6277 67 0	247		
GS-D70210RW	krēmbalta 2000 / gab. / FS	5665564	6278 40 1	260	GS-E70170RW	dzidri balts / gab. / FS	5662464	6277 67 0	252		
GS-D90170CW	krēmbalta 2000 / gab. / FS	5665144	6278 30 1	249	GS-E70210CW	krēmbalta / gab. / FS	5664062	6278 07 1	258		
GS-D90170LGR	gaiši pelēks 2000 / gab. / FS	5665151	6278 30 2	249	GS-E70210CW	krēmbalta / gab. / FS	5664062	6278 07 1	264		
GS-D90170RW	dzidri balts 2000 / gab. / FS	5665137	6278 30 0	249	GS-E70210LGR	gaiši pelēks / gab. / FS	5664079	6278 07 2	258		
GS-D90210CW	krēmbalta 2000 / gab. / FS	5666103	6278 50 1	260	GS-E70210LGR	gaiši pelēks / gab. / FS	5664079	6278 07 2	264		
GS-D90210LGR	gaiši pelēks 2000 / gab. / FS	5666110	6278 50 2	260	GS-E70210RW	dzidri balts / gab. / FS	5664055	6278 07 0	258		
GS-D90210RW	dzidri balts 2000 / gab. / FS	5666097	6278 50 0	260	GS-E70210RW	dzidri balts / gab. / FS	5664055	6278 07 0	264		
GS-DA70170CW	krēmbalta / gab. / FS	5664796	6278 21 1	€/gab.	250	GS-E90110CW	krēmbalta / gab. / FS	5659938	6277 17 1	€/gab.	226
GS-DA70170LGR	gaiši pelēks / gab. / FS	5664802	6278 21 2		250	GS-E90110LGR	gaiši pelēks / gab. / FS	5659945	6277 17 2		226
GS-DA70170RW	dzidri balts / gab. / FS	5664789	6278 21 0	250	GS-E90110RW	dzidri balts / gab. / FS	5659921	6277 17 0	226		
GS-DA70210CW	krēmbalta / gab. / FS	5665632	6278 41 1	262	GS-E90130CW	krēmbalta / gab. / FS	5661061	6277 37 1	231		
GS-DA70210LGR	gaiši pelēks / gab. / FS	5665649	6278 41 2	262	GS-E90130CW	krēmbalta / gab. / FS	5661061	6277 37 1	236		
GS-DA70210RW	dzidri balts / gab. / FS	5665625	6278 41 0	262	GS-E90130LGR	gaiši pelēks / gab. / FS	5661078	6277 37 2	231		
GS-DA90170CW	krēmbalta / gab. / FS	5665212	6278 31 1	251	GS-E90130LGR	gaiši pelēks / gab. / FS	5661078	6277 37 2	236		
GS-DA90170LGR	gaiši pelēks / gab. / FS	5665229	6278 31 2	251	GS-E90130RW	dzidri balts / gab. / FS	5661023	6277 37 0	231		
GS-DA90170RW	dzidri balts / gab. / FS	5665205	6278 31 0	251	GS-E90130RW	dzidri balts / gab. / FS	5661023	6277 37 0	236		
GS-DA90210CW	krēmbalta / gab. / FS	5666172	6278 51 1	262	GS-E90170CW	krēmbalta / gab. / FS	5662884	6277 77 1	242		
GS-DA90210LGR	gaiši pelēks / gab. / FS	5666189	6278 51 2	262	GS-E90170CW	krēmbalta / gab. / FS	5662884	6277 77 1	247		
GS-DA90210RW	dzidri balts / gab. / FS	5666165	6278 51 0	262	GS-E90170CW	krēmbalta / gab. / FS	5662884	6277 77 1	253		
GS-DF70170CW	krēmbalta / gab. / FS	5664918	6278 23 1	251	GS-E90170LGR	gaiši pelēks / gab. / FS	5662914	6277 77 2	242		
GS-DF70170LGR	gaiši pelēks / gab. / FS	5664925	6278 23 2	251	GS-E90170LGR	gaiši pelēks / gab. / FS	5662914	6277 77 2	247		
GS-DF70170RW	dzidri balts / gab. / FS	5664901	6278 23 0	251	GS-E90170LGR	gaiši pelēks / gab. / FS	5662914	6277 77 2	253		
GS-DF70210CW	krēmbalta / gab. / FS	5665823	6278 43 1	263	GS-E90170RW	dzidri balts / gab. / FS	5662877	6277 77 0	242		
GS-DF70210LGR	gaiši pelēks / gab. / FS	5665878	6278 43 2	263	GS-E90170RW	dzidri balts / gab. / FS	5662877	6277 77 0	247		
GS-DF70210RW	dzidri balts / gab. / FS	5665816	6278 43 0	263	GS-E90210CW	krēmbalta / gab. / FS	5664604	6278 17 1	253		
GS-DF90170CW	krēmbalta / gab. / FS	5665342	6278 33 1	251	GS-E90210CW	krēmbalta / gab. / FS	5664604	6278 17 1	258		
GS-DF90170LGR	gaiši pelēks / gab. / FS	5665380	6278 33 2	251	GS-E90210LGR	gaiši pelēks / gab. / FS	5664611	6278 17 2	264		
GS-DF90170RW	dzidri balts / gab. / FS	5665335	6278 33 0	251	GS-E90210LGR	gaiši pelēks / gab. / FS	5664611	6278 17 2	258		
GS-DF90210CW	krēmbalta / gab. / FS	5666264	6278 53 1	263	GS-E90210RW	dzidri balts / gab. / FS	5664567	6278 17 0	264		
GS-DF90210LGR	gaiši pelēks / gab. / FS	5666271	6278 53 2	263	GS-E90210RW	dzidri balts / gab. / FS	5664567	6278 17 0	264		
GS-DF90210RW	dzidri balts / gab. / FS	5666257	6278 53 0	263							
GS-DFS70170CW	krēmbalta / gab. / FS	5664840	6278 22 1	251	GS-KUP70	120 / V2A	5660590	6277 29 0	222		
GS-DFS70170LGR	gaiši pelēks / gab. / FS	5664857	6278 22 2	251	GS-KUP70	120 / V2A	5660590	6277 29 0	227		
GS-DFS70170RW	dzidri balts / gab. / FS	5664833	6278 22 0	251	GS-KUP70	120 / V2A	5660590	6277 29 0	232		
GS-DFS70210CW	krēmbalta / gab. / FS	5665755	6278 42 1	262	GS-KUP70	120 / V2A	5660590	6277 29 0	238		
GS-DFS70210LGR	gaiši pelēks / gab. / FS	5665762	6278 42 2	262	GS-KUP70	120 / V2A	5660590	6277 29 0	243		
GS-DFS70210RW	dzidri balts / gab. / FS	5665700	6278 42 0	262	GS-KUP70	120 / V2A	5660590	6277 29 0	249		
GS-DFS90170CW	krēmbalta / gab. / FS	5665267	6278 32 1	251	GS-KUP70	120 / V2A	5660590	6277 29 0	254		
GS-DFS90170LGR	gaiši pelēks / gab. / FS	5665274	6278 32 2	251	GS-KUP70	120 / V2A	5660590	6277 29 0	260		
GS-DFS90170RW	dzidri balts / gab. / FS	5665250	6278 32 0	251	GS-KUP90	/ V2A	5700852	6277 29 4	222		
GS-DFS90210CW	krēmbalta / gab. / FS	5666226	6278 52 1	262	GS-KUP90	/ V2A	5700852	6277 29 4	227		
GS-DFS90210LGR	gaiši pelēks / gab. / FS	5666233	6278 52 2	262	GS-KUP90	/ V2A	5700852	6277 29 4	232		
GS-DFS90210RW	dzidri balts / gab. / FS	5666219	6278 52 0	262	GS-KUP90	/ V2A	5700852	6277 29 4	238		
GS-DI70170CW	krēmbalta / gab. / FS	5665021	6278 24 1	252	GS-KUP90	/ V2A	5700852	6277 29 4	243		
GS-DI70170LGR	gaiši pelēks / gab. / FS	5665038	6278 24 2	252	GS-KUP90	/ V2A	5700852	6277 29 4	249		
GS-DI70170RW	dzidri balts / gab. / FS	5664987	6278 24 0	252	GS-KUP90	/ V2A	5700852	6277 29 4	254		
GS-DI70210CW	krēmbalta / gab. / FS	5665946	6278 44 1	263	GS-KUP90	/ V2A	5700852	6277 29 4	260		
GS-DI70210LGR	gaiši pelēks / gab. / FS	5665984	6278 44 2	263							
GS-DI70210RW	dzidri balts / gab. / FS	5665939	6278 44 0	263							
GS-DI90170CW	krēmbalta / gab. / FS	5665465	6278 34 1	252	GS-OT50CW	krēmbalta 2000 / gab. / FS	5680932	6279 88 1	250		
GS-DI90170LGR	gaiši pelēks / gab. / FS	5665472	6278 34 2	252	GS-OT50CW	krēmbalta 2000 / gab. / FS	5680932	6279 88 1	251		
GS-DI90170RW	dzidri balts / gab. / FS	5665458	6278 34 0	252							
GS-DI90210CW	krēmbalta / gab. / FS	5666318	6278 54 1	263	GS-OT50FCW	krēmbalta / gab.	5681106	6279 99 1	252		
GS-DI90210LGR	gaiši pelēks / gab. / FS	5666325	6278 54 2	263	GS-OT50FLGR	gaiši pelēks / gab.	5681113	6279 99 2	252		
GS-DI90210RW	dzidri balts / gab. / FS	5666301	6278 54 0	263	GS-OT50FRW	dzidri balts / gab.	5681090	6279 99 0	252		
GS-DT70170CW	krēmbalta / gab. / FS	5665090	6278 26 1	252							
GS-DT70170LGR	gaiši pelēks / gab. / FS	5665106	6278 26 2	252	GS-OT50LGR	gaiši pelēks 2000 / gab. / FS	5680949	6279 88 2	250		
GS-DT70170RW	dzidri balts / gab. / FS	5665083	6278 26 0	252	GS-OT50LGR	gaiši pelēks 2000 / gab. / FS	5680949	6279 88 2	251		
GS-DT70210CW	krēmbalta / gab. / FS	5666059	6278 46 1	264	GS-OT50RW	dzidri balts 2000 / gab. / FS	5680925	6279 88 0	250		
GS-DT70210LGR	gaiši pelēks / gab. / FS	5666066	6278 46 2	264	GS-OT50RW	dzidri balts 2000 / gab. / FS	5680925	6279 88 0	251		
GS-DT70210RW	dzidri balts / gab. / FS	5666042	6278 46 0	264							
GS-DT90170CW	krēmbalta / gab. / FS	5665519	6278 36 1	252	GS-OTACW	krēmbalta / gab.	5696063	6279 87 1	224		
GS-DT90170LGR	gaiši pelēks / gab. / FS	5665526	6278 36 2	252	GS-OTACW	krēmbalta / gab.	5696063	6279 87 1	229		
GS-DT90170RW	dzidri balts / gab. / FS	5665502	6278 36 0	252	GS-OTACW	krēmbalta / gab.	5696063	6279 87 1	234		
GS-DT90210CW	krēmbalta / gab. / FS	5666363	6278 56 1	264	GS-OTACW	krēmbalta / gab.	5696063	6279 87 1	240		
GS-DT90210LGR	gaiši pelēks / gab. / FS	5666370	6278 56 2	264	GS-OTACW	krēmbalta / gab.	5696063	6279 87 1	245		
GS-DT90210RW	dzidri balts / gab. / FS	5666356	6278 56 0	264	GS-OTACW	krēmbalta / gab.	5696063	6279 87 1	251		
					GS-OTACW	krēmbalta / gab.	5696063	6279 87 1	256		
GS-E70110CW	krēmbalta / gab. / FS	5659266	6277 07 1	226	GS-OTACW	krēmbalta / gab.	5696063	6279 87 1	262		
GS-E70110LGR	gaiši pelēks / gab. / FS	5659273	6277 07 2	226	GS-OTALGR	gaiši pelēks / gab.	5696100	6279 87 2	224		
GS-E70110RW	dzidri balts / gab. / FS	5659228	6277 07 0	226	GS-OTALGR	gaiši pelēks / gab.	5696100	6279 87 2	229		
GS-E70130CW	krēmbalta / gab. / FS	5660521	6277 27 1	231	GS-OTALGR	gaiši pelēks / gab.	5696100	6279 87 2	234		
GS-E70130LGR	gaiši pelēks / gab. / FS	5660521	6277 27 1	236	GS-OTALGR	gaiši pelēks / gab.	5696100	6279 87 2	240		
GS-E70130RW	dzidri balts / gab. / FS	5660538	6277 27 2	231	GS-OTALGR	gaiši pelēks / gab.	5696100	6279 87 2	245		
GS-E70130LGR	gaiši pelēks / gab. / FS	5660538	6277 27 2	236	GS-OTALGR	gaiši pelēks / gab.	5696100	6279 87 2	251		
GS-E70130RW	dzidri balts / gab. / FS	5660484	6277 27 0	231	GS-OTALGR	gaiši pelēks / gab.	5696100	6279 87 2	256		
GS-E70130RW	dzidri balts / gab. / FS	5660484	6277 27 0	236	GS-OTALGR	gaiši pelēks / gab.	5696100	6279 87 2	262		
GS-E70170CW	krēmbalta / gab. / FS	5662471	6277 67 1	242	GS-OTARW	dzidri balts / gab.	5696056	6279 87 0	224		
GS-E70170CW	krēmbalta / gab. / FS	5662471	6277 67 1	247	GS-OTARW	dzidri balts / gab.	5696056	6279 87 0	229		
GS-E70170CW	krēmbalta / gab. / FS	5662471	6277 67 1	252	GS-OTARW	dzidri balts / gab.	5696056	6279 87 0	234		
GS-E70170LGR	gaiši pelēks / gab. / FS	5662488	6277 67 2	242	GS-OTARW	dzidri balts / gab.	5696056	6279 87 0	240		

06 LFS\_Katalog\_2010\_Neuer\_Stand /lv/ 12/07/2011 (LLEExport\_01304)

# Tipu saraksts

EAN numura uzbūve: valsts kods 40

ražotāja kods 1219 (art. numuriem, kas sākas ar 0: 1010)

individuālais EAN-C 5647589

Tips	Izmērs/krāsa/cits	EAN-C.	Art.-Nr.	Cena	Lapa	Tips	Izmērs/krāsa/cits	EAN-C.	Art.-Nr.	Cena	Lapa
GS-OTARW	dzidri balts / gab.	5696056	6279 87 0	€/gab.	245	GS-SA90110RW	dzidri balts / gab. / FS	5659518	6277 11 0	€/gab.	224
GS-OTARW	dzidri balts / gab.	5696056	6279 87 0		251	GS-SA90130CW	krēmbalta / gab. / FS	5660774	6277 31 1		229
GS-OTARW	dzidri balts / gab.	5696056	6279 87 0		256	GS-SA90130LGR	gaiši pelēks / gab. / FS	5660781	6277 31 2		229
GS-OTARW	dzidri balts / gab.	5696056	6279 87 0		262	GS-SA90130RW	dzidri balts / gab. / FS	5660767	6277 31 0		229
GS-OTCW	krēmbalta2000 / gab.	5695820	6279 85 1	€/m	223	GS-SA90170CW	krēmbalta / gab. / FS	5662594	6277 71 1	240	
GS-OTCW	krēmbalta2000 / gab.	5695820	6279 85 1		228	GS-SA90170LGR	gaiši pelēks / gab. / FS	5662600	6277 71 2	240	
GS-OTCW	krēmbalta2000 / gab.	5695820	6279 85 1		233	GS-SA90170RW	dzidri balts / gab. / FS	5662587	6277 71 0	240	
GS-OTCW	krēmbalta2000 / gab.	5695820	6279 85 1		239	GS-SFS70110CW	krēmbalta / gab. / FS	5658979	6277 02 1	224	
GS-OTCW	krēmbalta2000 / gab.	5695820	6279 85 1		244	GS-SFS70110LGR	gaiši pelēks / gab. / FS	5658986	6277 02 2	224	
GS-OTCW	krēmbalta2000 / gab.	5695820	6279 85 1		250	GS-SFS70110RW	dzidri balts / gab. / FS	5658962	6277 02 0	224	
GS-OTCW	krēmbalta2000 / gab.	5695820	6279 85 1		255	GS-SFS70130CW	krēmbalta / gab. / FS	5660286	6277 22 1	229	
GS-OTCW	krēmbalta2000 / gab.	5695820	6279 85 1		261	GS-SFS70130LGR	gaiši pelēks / gab. / FS	5660293	6277 22 2	229	
GS-OTCW	krēmbalta2000 / gab.	5695820	6279 85 1		261	GS-SFS70130RW	dzidri balts / gab. / FS	5660248	6277 22 0	229	
GS-OTFCW	krēmbalta / gab.	5695943	6279 86 1		€/gab.	225	GS-SFS70170CW	krēmbalta / gab. / FS	5662327	6277 62 1	240
GS-OTFCW	krēmbalta / gab.	5695943	6279 86 1			230	GS-SFS70170LGR	gaiši pelēks / gab. / FS	5662334	6277 62 2	240
GS-OTFCW	krēmbalta / gab.	5695943	6279 86 1			235	GS-SFS70170RW	dzidri balts / gab. / FS	5662310	6277 62 0	240
GS-OTFCW	krēmbalta / gab.	5695943	6279 86 1	241		GS-SFS90110CW	krēmbalta / gab. / FS	5659631	6277 12 1	224	
GS-OTFCW	krēmbalta / gab.	5695943	6279 86 1	246		GS-SFS90110LGR	gaiši pelēks / gab. / FS	5659648	6277 12 2	224	
GS-OTFCW	krēmbalta / gab.	5695943	6279 86 1	252		GS-SFS90110RW	dzidri balts / gab. / FS	5659624	6277 12 0	224	
GS-OTFCW	krēmbalta / gab.	5695943	6279 86 1	257		GS-SFS90130CW	krēmbalta / gab. / FS	5660828	6277 32 1	230	
GS-OTFCW	krēmbalta / gab.	5695943	6279 86 1	263		GS-SFS90130LGR	gaiši pelēks / gab. / FS	5660835	6277 32 2	230	
GS-OTFCW	krēmbalta / gab.	5695943	6279 86 1	263		GS-SFS90130RW	dzidri balts / gab. / FS	5660811	6277 32 0	230	
GS-OTFLGR	gaiši pelēks / gab.	5695981	6279 86 2	225		GS-SFS90170CW	krēmbalta / gab. / FS	5662648	6277 72 1	240	
GS-OTFLGR	gaiši pelēks / gab.	5695981	6279 86 2	230		GS-SFS90170LGR	gaiši pelēks / gab. / FS	5662679	6277 72 2	240	
GS-OTFLGR	gaiši pelēks / gab.	5695981	6279 86 2	235		GS-SFS90170RW	dzidri balts / gab. / FS	5662631	6277 72 0	240	
GS-OTFLGR	gaiši pelēks / gab.	5695981	6279 86 2	241		GS-SI70110CW	krēmbalta / gab. / FS	5659082	6277 04 1	225	
GS-OTFLGR	gaiši pelēks / gab.	5695981	6279 86 2	246		GS-SI70110LGR	gaiši pelēks / gab. / FS	5659099	6277 04 2	225	
GS-OTFLGR	gaiši pelēks / gab.	5695981	6279 86 2	252		GS-SI70110RW	dzidri balts / gab. / FS	5659044	6277 04 0	225	
GS-OTFLGR	gaiši pelēks / gab.	5695981	6279 86 2	257		GS-SI70130CW	krēmbalta / gab. / FS	5660330	6277 24 1	230	
GS-OTFLGR	gaiši pelēks / gab.	5695981	6279 86 2	263		GS-SI70130LGR	gaiši pelēks / gab. / FS	5660347	6277 24 2	230	
GS-OTFRW	dzidri balts / gab.	5695936	6279 86 0	225		GS-SI70130RW	dzidri balts / gab. / FS	5660323	6277 24 0	230	
GS-OTFRW	dzidri balts / gab.	5695936	6279 86 0	230		GS-SI70170CW	krēmbalta / gab. / FS	5662372	6277 64 1	241	
GS-OTFRW	dzidri balts / gab.	5695936	6279 86 0	235		GS-SI70170LGR	gaiši pelēks / gab. / FS	5662389	6277 64 2	241	
GS-OTFRW	dzidri balts / gab.	5695936	6279 86 0	241		GS-SI70170RW	dzidri balts / gab. / FS	5662365	6277 64 0	241	
GS-OTFRW	dzidri balts / gab.	5695936	6279 86 0	246		GS-SI90110CW	krēmbalta / gab. / FS	5659747	6277 14 1	225	
GS-OTFRW	dzidri balts / gab.	5695936	6279 86 0	252		GS-SI90110LGR	gaiši pelēks / gab. / FS	5659754	6277 14 2	225	
GS-OTFRW	dzidri balts / gab.	5695936	6279 86 0	257		GS-SI90110RW	dzidri balts / gab. / FS	5659709	6277 14 0	225	
GS-OTFRW	dzidri balts / gab.	5695936	6279 86 0	263		GS-SI90130CW	krēmbalta / gab. / FS	5660873	6277 34 1	230	
GS-OTFRW	dzidri balts / gab.	5695936	6279 86 0	263		GS-SI90130LGR	gaiši pelēks / gab. / FS	5660880	6277 34 2	230	
GS-OTLGR	gaiši pelēks2000 / gab.	5695868	6279 85 2	223		GS-SI90130RW	dzidri balts / gab. / FS	5660866	6277 34 0	230	
GS-OTLGR	gaiši pelēks2000 / gab.	5695868	6279 85 2	228		GS-SI90170CW	krēmbalta / gab. / FS	5662716	6277 74 1	241	
GS-OTLGR	gaiši pelēks2000 / gab.	5695868	6279 85 2	233		GS-SI90170LGR	gaiši pelēks / gab. / FS	5662723	6277 74 2	241	
GS-OTLGR	gaiši pelēks2000 / gab.	5695868	6279 85 2	239		GS-SI90170RW	dzidri balts / gab. / FS	5662709	6277 74 0	241	
GS-OTLGR	gaiši pelēks2000 / gab.	5695868	6279 85 2	244		GS-ST70110CW	krēmbalta / gab. / FS	5659167	6277 06 1	225	
GS-OTLGR	gaiši pelēks2000 / gab.	5695868	6279 85 2	250		GS-ST70110LGR	gaiši pelēks / gab. / FS	5659204	6277 06 2	225	
GS-OTLGR	gaiši pelēks2000 / gab.	5695868	6279 85 2	255		GS-ST70110RW	dzidri balts / gab. / FS	5659150	6277 06 0	225	
GS-OTLGR	gaiši pelēks2000 / gab.	5695868	6279 85 2	261		GS-ST70130CW	krēmbalta / gab. / FS	5660415	6277 26 1	230	
GS-OTRW	dzidri balts2000 / gab.	5695813	6279 85 0	223		GS-ST70130LGR	gaiši pelēks / gab. / FS	5660422	6277 26 2	230	
GS-OTRW	dzidri balts2000 / gab.	5695813	6279 85 0	228		GS-ST70130RW	dzidri balts / gab. / FS	5660408	6277 26 0	230	
GS-OTRW	dzidri balts2000 / gab.	5695813	6279 85 0	233		GS-ST70170CW	krēmbalta / gab. / FS	5662426	6277 66 1	241	
GS-OTRW	dzidri balts2000 / gab.	5695813	6279 85 0	239		GS-ST70170LGR	gaiši pelēks / gab. / FS	5662433	6277 66 2	241	
GS-OTRW	dzidri balts2000 / gab.	5695813	6279 85 0	244		GS-ST70170RW	dzidri balts / gab. / FS	5662419	6277 66 0	241	
GS-OTRW	dzidri balts2000 / gab.	5695813	6279 85 0	250		GS-ST90110CW	krēmbalta / gab. / FS	5659822	6277 16 1	226	
GS-OTRW	dzidri balts2000 / gab.	5695813	6279 85 0	255		GS-ST90110LGR	gaiši pelēks / gab. / FS	5659860	6277 16 2	226	
GS-OTRW	dzidri balts2000 / gab.	5695813	6279 85 0	261		GS-ST90110RW	dzidri balts / gab. / FS	5659815	6277 16 0	226	
GS-S70110CW	krēmbalta2000 / gab. / FS	5658733	6277 00 1	222		GS-ST90130CW	krēmbalta / gab. / FS	5660958	6277 36 1	231	
GS-S70110LGR	gaiši pelēks2000 / gab. / FS	5658740	6277 00 2	222		GS-ST90130LGR	gaiši pelēks / gab. / FS	5660965	6277 36 2	231	
GS-S70110RW	dzidri balts2000 / gab. / FS	5658726	6277 00 0	222		GS-ST90130RW	dzidri balts / gab. / FS	5660941	6277 36 0	231	
GS-S70130CW	krēmbalta2000 / gab. / FS	5660040	6277 20 1	227		GS-ST90170CW	krēmbalta / gab. / FS	5662761	6277 76 1	241	
GS-S70130LGR	gaiši pelēks2000 / gab. / FS	5660057	6277 20 2	227		GS-ST90170LGR	gaiši pelēks / gab. / FS	5662815	6277 76 2	241	
GS-S70130RW	dzidri balts2000 / gab. / FS	5660002	6277 20 0	227		GS-ST90170RW	dzidri balts / gab. / FS	5662754	6277 76 0	241	
GS-S70170CW	krēmbalta2000 / gab. / FS	5662181	6277 60 1	238					€/m		
GS-S70170LGR	gaiši pelēks2000 / gab. / FS	5662198	6277 60 2	238	GS-TW70	2000 / gab.	5659334	6277 09 0	226		
GS-S70170RW	dzidri balts2000 / gab. / FS	5662174	6277 60 0	238	GS-TW70	2000 / gab.	5659334	6277 09 0	231		
GS-S90110CW	krēmbalta2000 / gab. / FS	5659396	6277 10 1	222	GS-TW70	2000 / gab.	5659334	6277 09 0	236		
GS-S90110LGR	gaiši pelēks2000 / gab. / FS	5659402	6277 10 2	222	GS-TW70	2000 / gab.	5659334	6277 09 0	242		
GS-S90110RW	dzidri balts2000 / gab. / FS	5659389	6277 10 0	222	GS-TW70	2000 / gab.	5659334	6277 09 0	247		
GS-S90130CW	krēmbalta2000 / gab. / FS	5660644	6277 30 1	227	GS-TW70	2000 / gab.	5659334	6277 09 0	253		
GS-S90130LGR	gaiši pelēks2000 / gab. / FS	5660651	6277 30 2	227	GS-TW70	2000 / gab.	5659334	6277 09 0	258		
GS-S90130RW	dzidri balts2000 / gab. / FS	5660606	6277 30 0	227	GS-TW70	2000 / gab.	5659334	6277 09 0	264		
GS-S90170CW	krēmbalta2000 / gab. / FS	5662525	6277 70 1	238	GS-TW90	2000 / gab.	5659341	6277 09 5	226		
GS-S90170LGR	gaiši pelēks2000 / gab. / FS	5662532	6277 70 2	238	GS-TW90	2000 / gab.	5659341	6277 09 5	231		
GS-S90170RW	dzidri balts2000 / gab. / FS	5662518	6277 70 0	238	GS-TW90	2000 / gab.	5659341	6277 09 5	236		
GS-SA70110CW	krēmbalta / gab. / FS	5658863	6277 01 1	€/gab.	224	GS-TW90	2000 / gab.	5659341	6277 09 5	242	
GS-SA70110LGR	gaiši pelēks / gab. / FS	5658900	6277 01 2		224	GS-TW90	2000 / gab.	5659341	6277 09 5	247	
GS-SA70110RW	dzidri balts / gab. / FS	5658856	6277 01 0		224	GS-TW90	2000 / gab.	5659341	6277 09 5	253	
GS-SA70130CW	krēmbalta / gab. / FS	5660170	6277 21 1		229	GS-TW90	2000 / gab.	5659341	6277 09 5	258	
GS-SA70130LGR	gaiši pelēks / gab. / FS	5660187	6277 21 2		229	GS-TW90	2000 / gab.	5659341	6277 09 5	264	
GS-SA70130RW	dzidri balts / gab. / FS	5660163	6277 21 0		229					€/gab.	
GS-SA70170CW	krēmbalta / gab. / FS	5662259	6277 61 1		240	G-SVS70110CW	krēmbalta / gab.	5667674	6279 76 1	223	
GS-SA70170LGR	gaiši pelēks / gab. / FS	5662266	6277 61 2		240	G-SVS70110LGR	gaiši pelēks / gab.	5667681	6279 76 2	223	
GS-SA70170RW	dzidri balts / gab. / FS	5662242	6277 61 0		240	G-SVS70110RW	dzidri balts / gab.	5667667	6279 76 0	223	
GS-SA90110CW	krēmbalta / gab. / FS	5659525	6277 11 1		224	G-SVS70130CW	krēmbalta / gab.	5667711	6279 76 5	228	
GS-SA90110LGR	gaiši pelēks / gab. / FS	5659563	6277 11 2		224	G-SVS70130LGR	krēmbalta / gab.	5667711	6279 76 5	233	

Tips	Izmērs/krāsa/cits	EAN-C.	Art.-Nr.	Cena	Lapa	Tips	Izmērs/krāsa/cits	EAN-C.	Art.-Nr.	Cena	Lapa	
G-SVS70130LGR	gaiši pelēks / gab.	5667728	6279 76 6	€/gab.	228	ISS140100FRW	dzidri balts / Alumīnijs	5477419	6289 05 0		331	
G-SVS70130LGR	gaiši pelēks / gab.	5667728	6279 76 6		233	ISS140100REL	/ Alumīnijs / EL	5477044	6289 07 3		331	
G-SVS70130RW	dzidri balts / gab.	5667704	6279 76 4		228	ISS140100RRW	dzidri balts / Alumīnijs	5477433	6289 07 0		331	
G-SVS70130RW	dzidri balts / gab.	5667704	6279 76 4		233	ISS140110EL	/ Alumīnijs / EL	5160908	6288 96 3		326	
G-SVS70170CW	krēmbalta / gab.	5667759	6279 76 9		239	ISS140110RW	dzidri balts / Alumīnijs	5160861	6288 96 0		326	
G-SVS70170CW	krēmbalta / gab.	5667759	6279 76 9		244	ISS140220EL	/ Alumīnijs / EL	5160977	6288 97 3		327	
G-SVS70170CW	krēmbalta / gab.	5667759	6279 76 9		250	ISS140220RW	dzidri balts / Alumīnijs	5160960	6288 97 0		327	
G-SVS70170LGR	gaiši pelēks / gab.	5667766	6279 77 0		239							
G-SVS70170LGR	gaiši pelēks / gab.	5667766	6279 77 0		244	ISS70110EL	/ Alumīnijs / EL	5160748	6288 94 3		324	
G-SVS70170LGR	gaiši pelēks / gab.	5667766	6279 77 0		250	ISS70110RW	dzidri balts / Alumīnijs	5160731	6288 94 0		324	
G-SVS70170RW	dzidri balts / gab.	5667742	6279 76 8		239							
G-SVS70170RW	dzidri balts / gab.	5667742	6279 76 8		244	ISS90110EL	/ Alumīnijs / EL	5160847	6288 95 3		325	
G-SVS70170RW	dzidri balts / gab.	5667742	6279 76 8		250	ISS90110RW	dzidri balts / Alumīnijs / EL	5160809	6288 95 0		325	
G-SVS70210CW	krēmbalta / gab.	5667797	6279 77 3		255	ISS98 61OT3RW	dzidri balts / gab.	5143765	6286 55 0		318	
G-SVS70210CW	krēmbalta / gab.	5667797	6279 77 3		261	ISS98 71OT3KRW	dzidri balts / gab.	5143819	6286 56 0		318	
G-SVS70210LGR	gaiši pelēks / gab.	5667803	6279 77 4		255	ISS98B	dzidri balts / PVC	5144045	6286 80 0		318	
G-SVS70210LGR	gaiši pelēks / gab.	5667803	6279 77 4		261	ISS98KF	/ gab. / FS	5144052	6286 80 2		319	
G-SVS70210RW	dzidri balts / gab.	5667780	6279 77 2		255							
G-SVS70210RW	dzidri balts / gab.	5667780	6279 77 2		261	ISSAH	/ Alumīnijs / EL	5162001	6290 18 4		333	
G-SVS90110CW	krēmbalta / gab.	5667834	6279 77 7		223							
G-SVS90110LGR	gaiši pelēks / gab.	5667841	6279 77 8		223	ISSBP140110RW	dzidri balts / gab. / FSK	5161752	6290 13 0		326	
G-SVS90110RW	dzidri balts / gab.	5667827	6279 77 6		223	ISSBP140110WA	balta alumīnija / gab. / FSK	5161769	6290 13 4		326	
G-SVS90130CW	krēmbalta / gab.	5667872	6279 78 1		229	ISSBP70110RW	dzidri balts / gab. / FSK	5161578	6290 10 0		324	
G-SVS90130CW	krēmbalta / gab.	5667872	6279 78 1		233	ISSBP70110WA	balta alumīnija / gab. / FSK	5161585	6290 10 4		324	
G-SVS90130LGR	gaiši pelēks / gab.	5667889	6279 78 2		229	ISSBP70140RW	dzidri balts / gab. / FSK	5161691	6290 12 0		321	
G-SVS90130LGR	gaiši pelēks / gab.	5667889	6279 78 2		233	ISSBP70140RW	dzidri balts / gab. / FSK	5161691	6290 12 0		322	
G-SVS90130RW	dzidri balts / gab.	5667865	6279 78 0		229	ISSBP70140RW	dzidri balts / gab. / FSK	5161691	6290 12 0		323	
G-SVS90130RW	dzidri balts / gab.	5667865	6279 78 0		233	ISSBP70140WA	balta alumīnija / gab. / FSK	5161707	6290 12 4		321	
G-SVS90170CW	krēmbalta / gab.	5667919	6279 78 5		239	ISSBP70140WA	balta alumīnija / gab. / FSK	5161707	6290 12 4		322	
G-SVS90170CW	krēmbalta / gab.	5667919	6279 78 5		244	ISSBP70140WA	balta alumīnija / gab. / FSK	5161707	6290 12 4		323	
G-SVS90170CW	krēmbalta / gab.	5667919	6279 78 5		250	ISSBP90110RW	dzidri balts / gab.	5161639	6290 11 0		325	
G-SVS90170LGR	gaiši pelēks / gab.	5667926	6279 78 6		244	ISSBP90110WA	balta alumīnija / gab.	5161646	6290 11 4		325	
G-SVS90170LGR	gaiši pelēks / gab.	5667926	6279 78 6		239	ISSBW70140RW	dzidri balts / gab. / FSK	5161813	6290 15 0		321	
G-SVS90170LGR	gaiši pelēks / gab.	5667926	6279 78 6		250	ISSBW70140RW	dzidri balts / gab. / FSK	5161813	6290 15 0		323	
G-SVS90170RW	dzidri balts / gab.	5667902	6279 78 4		239							
G-SVS90170RW	dzidri balts / gab.	5667902	6279 78 4		244	ISSGU140110	melns / GUM	5161943	6290 17 6		326	
G-SVS90170RW	dzidri balts / gab.	5667902	6279 78 4		250	ISSGU70110	melns / GUM	5161882	6290 17 0		324	
G-SVS90210CW	krēmbalta / gab.	5667957	6279 78 9		255	ISSGU70140	melns / GUM	5161936	6290 17 4		321	
G-SVS90210CW	krēmbalta / gab.	5667957	6279 78 9		261	ISSGU70140	melns / GUM	5161936	6290 17 4		322	
G-SVS90210LGR	gaiši pelēks / gab.	5667964	6279 79 0		255	ISSGU70140	melns / GUM	5161936	6290 17 4		323	
G-SVS90210LGR	gaiši pelēks / gab.	5667964	6279 79 0		261	ISSGU90110	melns / GUM	5161929	6290 17 2		325	
G-SVS90210RW	dzidri balts / gab.	5667940	6279 78 8		255							
G-SVS90210RW	dzidri balts / gab.	5667940	6279 78 8		261	ISSHS140250EL	/ Alumīnijs / EL	5161264	6290 02 3		335	
HAT30	zils / PA	5465249	6290 20 1		333	ISSHS140250RW	dzidri balts / Alumīnijs	5161226	6290 02 0		335	
IKR4RW		5616559	6288 36 5		358	ISSHS140500EL	alumīnija / Alumīnijs / EL	5161325	6290 03 3		335	
IKR6RW	/ PVC	5694915	6288 36 9		358	ISSHS140500RW	dzidri balts / Alumīnijs	5161288	6290 03 0		335	
ISS BP3GN	zaišs 3000	5143987	6286 75 8		320	ISSHS140700EL	alumīnija / Alumīnijs / EL	5161387	6290 04 3		335	
ISS BP3GR	pelēkbalts 3000	5143949	6286 75 4		320	ISSHS140700RW	dzidri balts / Alumīnijs	5161349	6290 04 0		335	
ISS BP3RT	sarkans 3000	5143970	6286 75 6		320	ISSHS2D120EL	/ Alumīnijs / EL	5143758	6286 50 3		336	
ISS BP3SW	melns 3000	5143925	6286 75 0		320	ISSHS2D120LGR	gaiši pelēks / Alumīnijs	5143741	6286 50 2		336	
ISS BP4SW	melns 4000	5143932	6286 75 2		320	ISSHS2D120RW	dzidri balts / Alumīnijs	5143734	6286 50 0		336	
ISS110100FEL	/ Alumīnijs / EL	5477402	6289 04 3		320	ISSHS4 61OT3LGR	gaiši pelēks / gab.	5143918	6286 70 2		334	
ISS110100FRW	dzidri balts / Alumīnijs	5477013	6289 04 0	320	ISSHS4 61OT3RW	dzidri balts / gab.	5143888	6286 70 0		334		
ISS110100REL	/ Alumīnijs / EL	5477426	6289 06 3	320	ISSHS4SR40	grafīta melns / gab.	5144090	6286 81 0		334		
ISS110100RRW	dzidri balts / Alumīnijs	5477037	6289 06 0	320	ISSHS6RW	/ Alumīnijs / EL	5161561	6290 07 3		336		
ISS120 245EL	2450 / Alumīnijs / EL	5142607	6286 00 3	320	ISSHSO270140EL	/ Alumīnijs / EL	5161516	6290 06 3		335		
ISS120 245RW	dzidri balts 2450 / Alumīnijs	5142560	6286 00 0	320	ISSHSO270140RW	dzidri balts / Alumīnijs	5161509	6290 06 0		335		
ISS120 300EL	3000 / Alumīnijs / EL	5143017	6286 11 3	320	ISSHSO70140EL	/ Alumīnijs / EL	5161455	6290 05 3		335		
ISS120 300RW	dzidri balts 3000 / Alumīnijs	5142980	6286 11 0	320	ISSHSO70140RW	dzidri balts / Alumīnijs	5161448	6290 05 0		335		
ISS120 310EL	3100 / Alumīnijs / EL	5143086	6286 13 3	320	ISSO70140EL	/ Alumīnijs / EL	5160601	6288 92 3		322		
ISS120 310RW	dzidri balts 3100 / Alumīnijs	5143079	6286 13 0	320	ISSO70140RW	dzidri balts / Alumīnijs	5160564	6288 92 0		322		
ISS120 325EL	3250 / Alumīnijs / EL	5143192	6286 16 3	320	ISSRGU	melns / GUM	5428152	6290 17 8		328		
ISS120 325RW	dzidri balts 3250 / Alumīnijs	5143161	6286 16 0	320	ISSRHSM45EL	/ Alumīnijs / EL	5428145	6290 09 1		336		
ISS120 330EL	3300 / Alumīnijs / EL	5143222	6286 17 3	320	ISSRHSM45RW	dzidri balts / Alumīnijs	5428138	6290 09 0		336		
ISS120 330RW	dzidri balts 3300 / Alumīnijs	5143208	6286 17 0	320	ISSRM45EL	/ Alumīnijs / EL	5428107	6290 08 7		327		
ISS120 340EL	3400 / Alumīnijs / EL	5143314	6286 19 3	320	ISSRM45FEL	/ Alumīnijs / EL	5428084	6290 08 3		328		
ISS120 340RW	dzidri balts 3400 / Alumīnijs	5143284	6286 19 0	320	ISSRM45FRW	dzidri balts / Alumīnijs	5428077	6290 08 2		328		
ISS120 345EL	3450 / Alumīnijs / EL	5143338	6286 20 3	320	ISSRM45RW	dzidri balts / Alumīnijs	5428091	6290 08 6		327		
ISS120 345RW	dzidri balts 3450 / Alumīnijs	5143321	6286 20 0	320	ISSSF	hroma melns / gab.	5161981	6290 18 0		333		
ISS120 355EL	3550 / Alumīnijs / EL	5143406	6286 22 3	320	ISST70140BEL	/ Alumīnijs / EL	5161219	6290 01 3		323		
ISS120 355RW	dzidri balts 3550 / Alumīnijs	5143383	6286 22 0	320	ISST70140BRW	dzidri balts / Alumīnijs	5161202	6290 01 0		323		
ISS120 370EL	3700 / Alumīnijs / EL	5143499	6286 25 3	320	ISST70140EL	/ Alumīnijs / EL	5160670	6288 93 3		321		
ISS120 370RW	dzidri balts 3700 / Alumīnijs	5143451	6286 25 0	320	ISST70140RW	dzidri balts / Alumīnijs	5160663	6288 93 0		321		
ISS120 395EL	3950 / Alumīnijs / EL	5143574	6286 29 3	320	ISSZ70140	dzidri balts / gab. / FSK	5161868	6290 16 0		321		
ISS120 395RW	dzidri balts 3950 / Alumīnijs	5143567	6286 29 0	320	ISSZ70140	dzidri balts / gab. / FSK	5161868	6290 16 0		323		
ISS120DDF7035	gaiši pelēks / gab.	5144007	6286 77 2	320	KA-ZKB AL1	alumīnija lakots	5677888	6117 98 7		349		
ISS120DDF9010	dzidri balts / gab.	5143994	6286 77 0	320	KA-ZKB RW1	dzidri balts	5677864	6117 98 5		349		
ISS120DDF9011RW	grafīta melns / gab.	5144038	6286 77 5	320	KA-ZKB SWGR1	pelēkmelna	5677871	6117 98 6		349		
ISS140100FEL	/ Alumīnijs / EL	5477020	6289 05 3	331								

06 LFS\_Katalog\_2010\_Neuer\_Stand /lv/ 12/07/2011 (LLEExport\_01304)

# Tipu saraksts

EAN numura uzbūve: valsts kods 40

ražotāja kods 1219 (art. numuriem, kas sākas ar 0: 1010)

individuālais EAN-C 5647589

Tips	Izmērs/krāsa/cits	EAN-C.	Art.-Nr.	Cena	Lapa	Tips	Izmērs/krāsa/cits	EAN-C.	Art.-Nr.	Cena	Lapa
KG2CW	krēmbalta/ Alumīnijs	5146582	6287 70 1	€/m	309	KUPA	55/ V2A	5148913	6288 66 7	€/gab.	268
KG2CW	krēmbalta/ Alumīnijs	5146674	6287 71 1		309	KUPA	55/ V2A	5148913	6288 66 7		271
KG2EL	/ Alumīnijs / EL	5146704	6287 72 3	309	KUPA	55/ V2A	5148913	6288 66 7	274		
KG2EL	/ Alumīnijs / EL	5146742	6287 73 3	309	KUPA	55/ V2A	5148913	6288 66 7	277		
KG2LGR	gaiši pelēks/ Alumīnijs	5146612	6287 70 2	309	KUPA	55/ V2A	5148913	6288 66 7	280		
KG2LGR	gaiši pelēks/ Alumīnijs	5146681	6287 71 2	309	KUPA	55/ V2A	5148913	6288 66 7	283		
KG2RW	dzidri balts/ Alumīnijs	5146575	6287 70 0	309	KUPA	55/ V2A	5148913	6288 66 7	286		
KG2RW	dzidri balts/ Alumīnijs	5146643	6287 71 0	309	KUPA	55/ V2A	5148913	6288 66 7	289		
				€/gab.		KUPA	55/ V2A	5148913	6288 66 7		292
KL80A	/ PA	5148777	6288 64 0	212	KVV	dzidri balts/ gab.	5733195	9002 09 7			295
KL80A	/ PA	5148777	6288 64 0	215							298
KL80A	/ PA	5148777	6288 64 0	218							301
KL80A	/ PA	5148777	6288 64 0	226							
KL80A	/ PA	5148777	6288 64 0	231	LK4 15015	akmens pelēks 2000/ PVC	6000050	6178 00 1		€/m	164
KL80A	/ PA	5148777	6288 64 0	236	LK4 30015	akmens pelēks 2000/ PVC	6000173	6178 00 3			164
KL80A	/ PA	5148777	6288 64 0	242	LK4 30025	akmens pelēks 2000/ PVC	6000296	6178 00 5			164
KL80A	/ PA	5148777	6288 64 0	247	LK4 40025	akmens pelēks 2000/ PVC	6000418	6178 01 0			164
KL80A	/ PA	5148777	6288 64 0	253	LK4 40040	akmens pelēks 2000/ PVC	6000531	6178 01 2			165
KL80A	/ PA	5148777	6288 64 0	258	LK4 40060	akmens pelēks 2000/ PVC	6000654	6178 01 4			165
KL80A	/ PA	5148777	6288 64 0	264	LK4 40080	akmens pelēks 2000/ PVC	6000777	6178 01 6			165
					LK4 40100	akmens pelēks 2000/ PVC	6000890	6178 01 8			165
					LK4 60015	akmens pelēks 2000/ PVC	6001132	6178 02 6			166
KNW1	150 melns/ POM	6014514	6178 52 7	184	LK4 60025	akmens pelēks 2000/ PVC	6001255	6178 02 8			166
KNW2	150 melns/ POM	6014637	6178 52 9	184	LK4 60040	akmens pelēks 2000/ PVC	6001378	6178 03 1			166
					LK4 60060	akmens pelēks 2000/ PVC	6001491	6178 03 3			166
					LK4 60080	akmens pelēks 2000/ PVC	6001613	6178 03 5			167
					LK4 60100	akmens pelēks 2000/ PVC	6001736	6178 03 7			167
KS70110	/ gab. / FS	5680697	6279 80 2	306	LK4 60120	akmens pelēks 2000/ PVC	6001859	6178 03 9			167
KS70130	/ gab. / FS	5680703	6279 80 4	306	LK4 80025	akmens pelēks 2000/ PVC	6002214	6178 05 0			167
KS70170	/ gab. / FS	5680734	6279 80 6	306	LK4 80040	akmens pelēks 2000/ PVC	6002337	6178 05 2			168
					LK4 80060	akmens pelēks 2000/ PVC	6002450	6178 05 4			168
KS990GN1-0	piparmētru zaļa	5404392	6288 61 7	357	LK4 80080	akmens pelēks 2000/ PVC	6002573	6178 05 6			168
KS990GN2-0	piparmētru zaļa	5404422	6288 62 0	357	LK4 80100	akmens pelēks 2000/ PVC	6002696	6178 05 9			168
KS990GN3-0	piparmētru zaļa	5404453	6288 62 3	357	LK4 80120	akmens pelēks 2000/ PVC	6002818	6178 06 1			169
KS990RT1-0	signālsarkana	5404408	6288 61 8	357	LK4 D 100	akmens pelēks 100/ PVC	6040803	6178 49 0			165
KS990RT2-0	signālsarkana	5404439	6288 62 1	357	LK4 D 100	akmens pelēks 100/ PVC	6040803	6178 49 0			167
KS990RT3-0	signālsarkana	5404460	6288 62 4	357	LK4 D 100	akmens pelēks 100/ PVC	6040803	6178 49 0			168
KS990RW1-0	dzidri balts	5404385	6288 61 6	357	LK4 D 100	akmens pelēks 100/ PVC	6040803	6178 49 0			171
KS990RW2-0	dzidri balts	5404415	6288 61 9	357	LK4 D 100	akmens pelēks 100/ PVC	6040803	6178 49 0			172
KS990RW3-0	dzidri balts	5404446	6288 62 2	357	LK4 D 120	akmens pelēks 120/ PVC	6040926	6178 49 2			167
					LK4 D 120	akmens pelēks 120/ PVC	6040926	6178 49 2			169
KS-B AL1	alumīnija lakots	5405931	6117 63 8	347	LK4 D 120	akmens pelēks 120/ PVC	6040926	6178 49 2			171
KS-B RW1	dzidri balts	5405924	6117 63 7	347	LK4 D 120	akmens pelēks 120/ PVC	6040926	6178 49 2			173
KS-B SWGR1	pelēkmelna	5701064	6117 63 9	347	LK4 D 15	akmens pelēks 15/ PVC	6040209	6178 48 0			164
					LK4 D 15	akmens pelēks 15/ PVC	6040209	6178 48 0			166
KSB990GN1-0	piparmētru zaļa	5404484	6288 62 6	357	LK4 D 15	akmens pelēks 15/ PVC	6040209	6178 48 0			170
KSB990GN2-0	piparmētru zaļa	5404514	6288 62 9	357	LK4 D 25	akmens pelēks 25/ PVC	6040322	6178 48 2			164
KSB990GN3-0	piparmētru zaļa	5404545	6288 63 2	358	LK4 D 25	akmens pelēks 25/ PVC	6040322	6178 48 2			164
KSB990RT1-0	signālsarkana	5404491	6288 62 7	357	LK4 D 25	akmens pelēks 25/ PVC	6040322	6178 48 2			166
KSB990RT2-0	signālsarkana	5404521	6288 63 0	357	LK4 D 25	akmens pelēks 25/ PVC	6040322	6178 48 2			167
KSB990RT3-0	signālsarkana	5404552	6288 63 3	358	LK4 D 25	akmens pelēks 25/ PVC	6040322	6178 48 2			170
KSB990RW1-0	dzidri balts	5404477	6288 62 5	357	LK4 D 25	akmens pelēks 25/ PVC	6040322	6178 48 2			171
KSB990RW2-0	dzidri balts	5404507	6288 62 8	357	LK4 D 40	akmens pelēks 40/ PVC	6040445	6178 48 4			165
KSB990RW3-0	dzidri balts	5404538	6288 63 1	358	LK4 D 40	akmens pelēks 40/ PVC	6040445	6178 48 4			166
					LK4 D 40	akmens pelēks 40/ PVC	6040445	6178 48 4			168
					LK4 D 40	akmens pelēks 40/ PVC	6040445	6178 48 4			170
				€/100 gab.		LK4 D 40	akmens pelēks 40/ PVC	6040445	6178 48 4		172
KSN1	gaiši pelēks 4,5/ PP	6014279	6178 52 0	184	LK4 D 60	akmens pelēks 60/ PVC	6040568	6178 48 6			165
KSN2	gaiši pelēks 6/ PP	6014392	6178 52 2	184	LK4 D 60	akmens pelēks 60/ PVC	6040568	6178 48 6			166
					LK4 D 60	akmens pelēks 60/ PVC	6040568	6178 48 6			168
					LK4 D 60	akmens pelēks 60/ PVC	6040568	6178 48 6			170
					LK4 D 60	akmens pelēks 60/ PVC	6040568	6178 48 6			172
KSP170	152/ gab. / FS	5680741	6279 81 0	306	LK4 D 80	akmens pelēks 80/ PVC	6040681	6178 48 8			165
KSP210	192/ gab. / FS	5680758	6279 81 2	306	LK4 D 80	akmens pelēks 80/ PVC	6040681	6178 48 8			167
					LK4 D 80	akmens pelēks 80/ PVC	6040681	6178 48 8			168
KSR20020	pelēks 28/ PE	6018598	6249 84 2	138	LK4 DM 15	akmens pelēks 15/ PVC	5049531	6178 47 9			171
KSR20030	pelēks 34/ PE	6018710	6249 84 4	139							172
KSR30030	pelēks 34/ PE	5691020	6249 84 5	140	LK4 H	akmens pelēks 56/ PS	6008339	6178 09 2		€/100 gab.	184
KSR40040	pelēks 47,7/ PE	6018833	6249 84 6	142	LK4 N 60015	akmens pelēks 2000/ PVC	6004850	6178 20 1		€/m	170
KSR40060	pelēks 47/ PE	6018956	6249 84 8	144	LK4 N 60025	akmens pelēks 2000/ PVC	6004973	6178 20 3			170
					LK4 N 60040	akmens pelēks 2000/ PVC	6005093	6178 20 5			170
					LK4 N 60060	akmens pelēks 2000/ PVC	6005215	6178 20 7			170
KSR60060	pelēks 67,7/ PE	6019076	6249 85 0	146	LK4 N 60080	akmens pelēks 2000/ PVC	6005307	6178 20 9			171
KSR60100	pelēks 104/ PE	5020325	6249 85 2	148	LK4 N 60100	akmens pelēks 2000/ PVC	6005406	6178 21 1			171
KSR60150	pelēks 154/ PE	5020387	6249 85 4	150	LK4 N 60120	akmens pelēks 2000/ PVC	6005505	6178 21 3			171
KSR60200	pelēks 204/ PE	5020394	6249 85 6	152	LK4 N 80025	akmens pelēks 2000/ PVC	6005802	6178 22 5			171
					LK4 N 80040	akmens pelēks 2000/ PVC	6005932	6178 22 7			172
KSR80080	pelēks 84/ PE	5691037	6249 86 5	154	LK4 N 80060	akmens pelēks 2000/ PVC	6006052	6178 22 9			172
					LK4 N 80080	akmens pelēks 2000/ PVC	6006175	6178 23 1			172

06 LFS\_Katalog\_2010\_Neuer\_Stand /lv / 12/07/2011 (LLEExport\_01304)

Tips	Izmērs/krāsa/cits	EAN-C.	Art.-Nr.	Cena	Lapa	Tips	Izmērs/krāsa/cits	EAN-C.	Art.-Nr.	Cena	Lapa
LK4 N 80100	akmens pelēks 2000/ PVC	6006298	6178 23 3	€/m	172	LKM T60200FS	440 gab. / FS	6317950	6248 22 5	€/gab.	151
LK4 N 80120	akmens pelēks 2000/ PVC	6006410	6178 23 6		173	LKM T60200RW	dzidri balts 440/ gab. / FSK	6318377	6249 73 6		151
				€/gab.		LKM T80080FS	300 gab. / FS	5699057	6248 34 0		153
							LKM T80080RW	dzidri balts 300/ gab. / FSK	5699125	6248 45 0	
LKM A40040FS	160/ gab. / FS	6652273	6247 56 3		141	LKM TWS55	2000 55/ gab. / FS	6644896	6249 87 6		155
LKM A40040RW	dzidri balts 160/ gab. / FSK	6652334	6249 08 6		141						
LKM A40060FS	160/ gab. / FS	6312733	6247 57 1		143	LKM Z100	96 30/ gab. / FS	6315499	6249 92 2		155
LKM A40060RW	dzidri balts 160/ gab. / FSK	6314232	6249 09 4		143	LKM Z150	146 30/ gab. / FS	6315611	6249 96 5		155
LKM A60060FS	180/ gab. / FS	6977062	6248 04 7		145	LKM Z200	166 30/ gab. / FS	6315673	6249 98 1		155
LKM A60060RW	dzidri balts 180/ gab. / FSK	6503650	6249 55 8		145	LKM Z60	46 30/ gab. / FS	6315376	6249 90 6		143
LKM A60100FS	180/ gab. / FS	6312979	6248 06 3		147	LKM Z60	46 30/ gab. / FS	6315376	6249 90 6		155
LKM A60100RW	dzidri balts 180/ gab. / FSK	6314898	6249 57 4		147						
LKM A60150FS	180/ gab. / FS	6313037	6248 07 1		149						
LKM A60150RW	dzidri balts 180/ gab. / FSK	6314959	6249 58 2		149	LKM20020FS	2000/ gab. / FS	6651672	6246 96 6		138
LKM A60200FS	180/ gab. / FS	6313099	6248 09 8		151	LKM20020RW	dzidri balts 2000/ gab. / FSK	6651795	6248 46 2		138
LKM A60200RW	dzidri balts 180/ gab. / FSK	6315017	6249 59 0		151	LKM20030FS	2000/ gab. / FS	6118878	6246 97 4		139
LKM A80080FS	200/ gab. / FS	5699033	6248 33 2		153	LKM20030RW	dzidri balts 2000/ gab. / FSK	6119059	6248 47 0		139
LKM A80080RW	dzidri balts 200/ gab. / FSK	5699101	6248 43 2		153						
LKM E40040FS	40/ gab. / FS	6652631	6247 88 1		141	LKM30030FS	2000/ gab. / FS	5690955	6246 98 2		140
LKM E40040RW	dzidri balts 40/ gab. / FSK	6652693	6249 41 8		141	LKM30030RW	dzidri balts 2000/ gab. / FS	5690962	6248 48 2		140
LKM E40060FS	60/ gab. / FS	6575114	6247 90 3		144						
LKM E40060RW	dzidri balts 60/ gab. / FSK	6575350	6249 42 6		144	LKM40040FS	2000/ gab. / FS	6651733	6246 99 0		141
LKM E60060FS	63/ gab. / FS	6503353	6248 28 4		145	LKM40040RW	dzidri balts 2000/ gab. / FSK	6651856	6248 49 7		141
LKM E60060RW	dzidri balts 63/ gab. / FSK	6503292	6249 79 5		145	LKM40060FS	2000/ gab. / FS	6311897	6248 01 6		143
LKM E60100FS	100/ gab. / FS	6575596	6248 30 6		147	LKM40060RW	dzidri balts 2000/ gab. / FSK	6313570	6248 51 9		143
LKM E60100RW	dzidri balts 100/ gab. / FSK	6575770	6249 81 7		147						
LKM E60150FS	150/ gab. / FS	6575657	6248 31 4		149	LKM60060FS	2000/ gab. / FS	6977369	6247 09 1		145
LKM E60150RW	dzidri balts 150/ gab. / FSK	6575831	6249 82 5		149	LKM60060RW	dzidri balts 2000/ gab. / FSK	6977307	6248 60 8		145
LKM E60200FS	200/ gab. / FS	6575718	6248 32 2		151	LKM60100FS	2000/ gab. / FS	6312139	6247 11 3		147
LKM E60200RW	dzidri balts 200/ gab. / FSK	6575893	6249 83 3		151	LKM60100RW	dzidri balts 2000/ gab. / FSK	6313815	6248 62 4		147
LKM E80080FS	80/ gab. / FS	5699064	6248 34 4		153	LKM60150CRW	dzidri balts 2000/ gab. / FSK	6313877	6248 64 0		149
LKM E80080RW	dzidri balts 80/ gab. / FSK	5699156	6248 45 4		153	LKM60150FS	2000/ gab. / FS	6312191	6247 14 8		149
LKM F40040FS	160/ gab. / FS	6652518	6247 49 0		141	LKM60200FS	2000/ gab. / FS	6312252	6247 16 4		151
LKM F40040RW	dzidri balts 160/ gab. / FSK	6652570	6248 99 3		141	LKM60200RW	dzidri balts 2000/ gab. / FSK	6313938	6248 66 7		151
LKM F40060FS	180/ gab. / FS	6312313	6247 50 4		143						
LKM F40060RW	dzidri balts 180/ gab. / FSK	6313990	6249 00 0		143	LKM80080FS	2000/ gab. / FS	5691006	6247 19 4		153
LKM F60060FS	180/ gab. / FS	6503476	6247 98 9		145	LKM80080RW	dzidri balts 2000/ gab. / FS	5691013	6248 69 4		153
LKM F60060RW	dzidri balts 180/ gab. / FSK	6503414	6249 48 5		145						
LKM F60100FS	220/ gab. / FS	6312559	6248 00 4		147						
LKM F60100RW	dzidri balts 220/ gab. / FSK	6314713	6249 50 7		147	LKV 100100	akmens pelēks 2000/ PVC	6011162	6178 34 1		178
LKM F60150FS	270/ gab. / FS	6312610	6248 01 2		149	LKV 10037	akmens pelēks 2000/ PVC	6010806	6178 33 4		177
LKM F60150RW	dzidri balts 270/ gab. / FSK	6314775	6249 51 5		149	LKV 10050	akmens pelēks 2000/ PVC	6010929	6178 33 6		177
LKM F60200FS	320/ gab. / FS	6312672	6248 02 0		151	LKV 10075	akmens pelēks 2000/ PVC	6011049	6178 33 8		177
LKM F60200RW	dzidri balts 320/ gab. / FSK	6314836	6249 52 3		151	LKV 25025	akmens pelēks 2000/ PVC	6009411	6178 30 2		174
LKM F80080FS	240/ gab. / FS	5699026	6248 32 8		153	LKV 37025	akmens pelēks 2000/ PVC	6009534	6178 30 5		174
LKM F80080RW	dzidri balts 240/ gab. / FSK	5699095	6248 42 8		153	LKV 37037	akmens pelēks 2000/ PVC	6009657	6178 30 7		174
LKM I40040FS	160/ gab. / FS	6652150	6247 65 2		141	LKV 50025	akmens pelēks 2000/ PVC	6009732	6178 31 0		174
LKM I40040RW	dzidri balts 160/ gab. / FSK	6652211	6249 16 7		141	LKV 50037	akmens pelēks 2000/ PVC	6009831	6178 31 2		175
LKM I40060FS	160/ gab. / FS	6313150	6247 66 0		143	LKV 50050	akmens pelēks 2000/ PVC	6009930	6178 31 4		175
LKM I40060RW	dzidri balts 160/ gab. / FSK	6314478	6249 17 5		143	LKV 50075	akmens pelēks 2000/ PVC	6010073	6178 31 6		175
LKM I60060FS	180/ gab. / FS	6977185	6248 12 8		145	LKV 75025	akmens pelēks 2000/ PVC	6010196	6178 32 0		175
LKM I60060RW	dzidri balts 180/ gab. / FSK	6977123	6249 61 2		145	LKV 75037	akmens pelēks 2000/ PVC	6010318	6178 32 5		176
LKM I60100FS	180/ gab. / FS	6313396	6248 14 4		147	LKV 75050	akmens pelēks 2000/ PVC	6010400	6178 32 4		176
LKM I60100RW	dzidri balts 180/ gab. / FSK	6315079	6249 63 9		147	LKV 75075	akmens pelēks 2000/ PVC	6010509	6178 32 6		176
LKM I60150FS	180/ gab. / FS	6313457	6248 15 2		149	LKV 75100	akmens pelēks 2000/ PVC	6010608	6178 32 8		176
LKM I60150RW	dzidri balts 180/ gab. / FSK	6315130	6249 64 7		149	LKV 75125	akmens pelēks 2000/ PVC	6010707	6178 33 0		177
LKM I60200FS	180/ gab. / FS	6313518	6248 16 0		151	LKV D 100	akmens pelēks 100/ PVC	6041763	6178 51 2		176
LKM I60200RW	dzidri balts 180/ gab. / FSK	6315192	6249 65 5		151	LKV D 100	akmens pelēks 100/ PVC	6041763	6178 51 2		178
LKM I80080FS	160/ gab. / FS	5699040	6248 33 6		153	LKV D 100	akmens pelēks 100/ PVC	6041763	6178 51 2		180
LKM I80080RW	dzidri balts 160/ gab. / FSK	5699118	6248 43 6		153	LKV D 100	akmens pelēks 100/ PVC	6041763	6178 51 2		181
				€/100 gab.		LKV D 125	akmens pelēks 125/ PVC	6041886	6178 51 4		177
LKM K140	25 140/ gab. / FS	6119295	6249 88 8			155	LKV D 125	akmens pelēks 125/ PVC	6041886	6178 51 4	
LKM K80	25 80/ gab. / FS	6119233	6249 88 4		155	LKV D 25	akmens pelēks 25/ PVC	6041282	6178 50 4		174
				€/gab.		LKV D 25	akmens pelēks 25/ PVC	6041282	6178 50 4		174
LKM KF 60100	/ gab. / FS	5685081	6249 88 1			148	LKV D 25	akmens pelēks 25/ PVC	6041282	6178 50 4	
LKM SV20	45 19,7/ gab. / G	6652754	6247 43 1		138	LKV D 25	akmens pelēks 25/ PVC	6041282	6178 50 4		175
LKM SV30	53,8 29,5/ gab. / G	6118991	6247 43 4		139	LKV D 25	akmens pelēks 25/ PVC	6041282	6178 50 4		179
LKM SV30	53,8 29,5/ gab. / G	6118991	6247 43 4		140	LKV D 37	akmens pelēks 37,5/ PVC	6041404	6178 50 6		174
LKM SV40	76 29,6/ V2A	6315253	6247 45 8		141	LKV D 37	akmens pelēks 37,5/ PVC	6041404	6178 50 6		175
LKM SV40	76 29,6/ V2A	6315253	6247 45 8		143	LKV D 37	akmens pelēks 37,5/ PVC	6041404	6178 50 6		176
LKM SV60	75 50/ V2A	6315314	6247 46 6		145	LKV D 37	akmens pelēks 37,5/ PVC	6041404	6178 50 6		177
LKM SV60	75 50/ V2A	6315314	6247 46 6		147	LKV D 37	akmens pelēks 37,5/ PVC	6041404	6178 50 6		179
LKM SV60	75 50/ V2A	6315314	6247 46 6		149	LKV D 37	akmens pelēks 37,5/ PVC	6041404	6178 50 6		180
LKM SV60	75 50/ V2A	6315314	6247 46 6		151	LKV D 50	akmens pelēks 50/ PVC	6041527	6178 50 8		175
LKM SV80	75 65,6/ gab.	5699019	6247 47 2		153	LKV D 50	akmens pelēks 50/ PVC	6041527	6178 50 8		176
LKM T40040FS	280/ gab. / FS	6652396	6247 72 5		141	LKV D 50	akmens pelēks 50/ PVC	6041527	6178 50 8		177
LKM T40040RW	dzidri balts 280/ gab. / FSK	6652457	6249 25 6		141	LKV D 50	akmens pelēks 50/ PVC	6041527	6178 50 8		179
LKM T40060FS	300/ gab. / FS	6317592	6247 73 3		143	LKV D 50	akmens pelēks 50/ PVC	6041527	6178 50 8		180
LKM T40060RW	dzidri balts 300/ gab. / FSK	6318018	6249 26 4		143	LKV D 75	akmens pelēks 75/ PVC	6041640	6178 51 0		175
LKM T60060FS	300/ gab. / FS	6503599	6248 18 7		145	LKV D 75	akmens pelēks 75/ PVC	6041640	6178 51 0		176
LKM T60060RW	dzidri balts 300/ gab. / FSK	6503537	6249 67 1		145	LKV D 75	akmens pelēks 75/ PVC	6041640	6178 51 0		177
LKM T60100FS	340/ gab. / FS	6317837	6248 20 9		147	LKV D 75	akmens pelēks 75/ PVC	6041640	6178 51 0		179
LKM T60100RW	dzidri balts 340/ gab. / FSK	6318254	6249 70 1		147	LKV D 75	akmens pelēks 75/ PVC	6041640	6178 51 0		181
LKM T60150FS	390/ gab. / FS	6317899	6248 21 7		149						
LKM T60150RW	dzidri balts 390/ gab. / FSK										

# Tipu saraksts

EAN numura uzbūve: valsts kods 40

ražotāja kods 1219 (art. numuriem, kas sākas ar 0: 1010)

individuālais EAN-C 5647589

Tips	Izmērs/krāsa/cits	EAN-C.	Art.-Nr.	Cena	Lapa	Tips	Izmērs/krāsa/cits	EAN-C.	Art.-Nr.	Cena	Lapa		
LKV H 50037	gaiši pelēks 2000 / PPO	6016266	6178 61 2	€/m	182	PV N3 75H	75	5147169	6288 10 2	€/gab.	307		
LKV H 50050	gaiši pelēks 2000 / PPO	6016389	6178 61 4		182								
LKV H 50075	gaiši pelēks 2000 / PPO	6016501	6178 61 6		182	PVV N2 100	100	5146865	6288 03 0		308		
LKV H 75037	gaiši pelēks 2000 / PPO	6016747	6178 62 2		182	PVV N2 125	125	5146872	6288 03 2		308		
LKV H 75050	gaiši pelēks 2000 / PPO	6016860	6178 62 4		182	PVV N2 150	150	5146889	6288 03 4		308		
LKV H 75075	gaiši pelēks 2000 / PPO	6016983	6178 62 6		182	PVV N2 175	175	5146919	6288 03 6		308		
LKV H 75100	gaiši pelēks 2000 / PPO	6017102	6178 62 8		182	PVV N2 200	200	5146926	6288 03 8		308		
LKV H 75125	gaiši pelēks 2000 / PPO	6017225	6178 63 0		183	PVV N2 225	225	5146933	6288 04 0		308		
					€/100 gab.								
LKV H H	gaiši pelēks 56 / PS	6017829	6178 65 0		184	PVV N2 275	275	5146940	6288 04 2		308		
					€/m								
LKV N 100100	akmens pelēks 2000 / PVC	6015184	6178 44 1		181	PVV N2 300	300	5297185	6288 07 0		308		
LKV N 10037	akmens pelēks 2000 / PVC	6013913	6178 43 5		180	PVV N2 325	325	5297192	6288 07 2		308		
LKV N 10050	akmens pelēks 2000 / PVC	6014033	6178 43 7		180	PVV N2 350	350	5297208	6288 07 4		308		
LKV N 10075	akmens pelēks 2000 / PVC	6014156	6178 43 9		181	PVV N2 400	400	5297222	6288 07 8		308		
LKV N 75025	akmens pelēks 2000 / PVC	6013197	6178 42 0		179	PVV N2 425	425	5297239	6288 08 0		308		
LKV N 75037	akmens pelēks 2000 / PVC	6013319	6178 42 2		179	PVV N2 450	450	5297246	6288 08 2		308		
LKV N 75050	akmens pelēks 2000 / PVC	6013432	6178 42 4		179	PVV N2 475	475	5146971	6288 04 4		308		
LKV N 75075	akmens pelēks 2000 / PVC	6013555	6178 42 6	179	PVV N2 500	500	5297253	6288 08 4	308				
LKV N 75100	akmens pelēks 2000 / PVC	6013678	6178 42 8	180	PVV N2 525	525	5297260	6288 08 6	308				
LKV N 75125	akmens pelēks 2000 / PVC	6013791	6178 43 0	180	PVV N2 550	550	5146988	6288 04 6	308				
				€/gab.									
MVKG70130	110 / gab. / FS	5680765	6279 82 0	307	PVV N2 575	575	5146995	6288 04 8	308				
MVKG70170	150 / gab. / FS	5680796	6279 82 2	307	PVV N2 600	600	5147000	6288 05 0	308				
MVKG70210	190 / gab. / FS	5680802	6279 82 4	307	PVV N2 625	625	5147039	6288 05 2	308				
MVKG90130	110 / gab. / FS	5680819	6279 82 6	307	PVV N2 650	650	5147046	6288 05 4	308				
MVKG90170	150 / gab. / FS	5680826	6279 82 8	307	PVV N2 675	675	5147053	6288 05 6	308				
MVKG90210	190 / gab. / FS	5680857	6279 83 0	307	PVV N2 700	700	5147060	6288 05 8	308				
				€/m									
MVKV70130	/ gab. / FS	5680864	6279 83 2	308	PVV N2 725	725	5147091	6288 06 0	308				
MVKV70170	/ gab. / FS	5680871	6279 83 4	308	PVV N2 750	750	5147107	6288 06 2	308				
MVKV70210	/ gab. / FS	5680888	6279 83 6	308	PVV N2 775	775	5297277	6288 08 8	308				
MVKV90130	/ gab. / FS	5680895	6279 83 8	309	PVV N2 800	800	5297284	6288 09 0	308				
MVKV90170	/ gab. / FS	5680901	6279 84 0	309	PVV N2 825	825	5297291	6288 09 2	308				
MVKV90210	/ gab. / FS	5680918	6279 84 2	309	PVV N2 850	850	5147114	6288 06 4	308				
				€/m									
OK-K 45	/ V2A	6176236	6116 11 6	188	PVV N2 875	875	5147121	6288 06 6	308				
OK-K 45	/ V2A	6176236	6116 11 6	191	PVV N2375	375	5297215	6288 07 6	308				
				€/m									
OT3V GEKA50EL	/ Alumīnijs / EL	5157625	6287 16 3	293									
OT3V GEKA50EL	/ Alumīnijs / EL	5157625	6287 16 3	296	RK-E1117GR	akmens pelēks 175 / PVC	6543137	6156 22 3	126				
OT3V GEKA50RW	dzidri balts / Alumīnijs	5157618	6287 16 0	293	RK-E1117LGR	gaiši pelēks 175 / PVC	6543076	6156 23 1	126				
OT3V GEKA50RW	dzidri balts / Alumīnijs	5157618	6287 16 0	296									
OT3V GEKA80EL	/ Alumīnijs / EL	5145196	6287 17 3	268	RK-K1117	120 166 / gab. / FS	6543199	6156 20 7	126				
OT3V GEKA80EL	/ Alumīnijs / EL	5145196	6287 17 3	271									
OT3V GEKA80EL	/ Alumīnijs / EL	5145196	6287 17 3	274									
OT3V GEKA80EL	/ Alumīnijs / EL	5145196	6287 17 3	277	RKV3V		5149088	6288 70 0	223				
OT3V GEKA80EL	/ Alumīnijs / EL	5145196	6287 17 3	280	RKV3V		5149088	6288 70 0	228				
OT3V GEKA80EL	/ Alumīnijs / EL	5145196	6287 17 3	283	RKV3V		5149088	6288 70 0	233				
OT3V GEKA80EL	/ Alumīnijs / EL	5145196	6287 17 3	286	RKV3V		5149088	6288 70 0	239				
OT3V GEKA80EL	/ Alumīnijs / EL	5145196	6287 17 3	289	RKV3V		5149088	6288 70 0	244				
OT3V GEKA80EL	/ Alumīnijs / EL	5145196	6287 17 3	292	RKV3V		5149088	6288 70 0	250				
OT3V GEKA80EL	/ Alumīnijs / EL	5145196	6287 17 3	295	RKV3V		5149088	6288 70 0	255				
OT3V GEKA80EL	/ Alumīnijs / EL	5145196	6287 17 3	298	RKV3V		5149088	6288 70 0	261				
OT3V GEKA80EL	/ Alumīnijs / EL	5145196	6287 17 3	301									
OT3V GEKA80RW	dzidri balts / Alumīnijs	5145189	6287 17 0	268	RS-BS1 AL1	alumīnija lakots	5276005	6117 65 5	347				
OT3V GEKA80RW	dzidri balts / Alumīnijs	5145189	6287 17 0	271	RS-BS1 RW1	dzidri balts	5275992	6117 65 4	347				
OT3V GEKA80RW	dzidri balts / Alumīnijs	5145189	6287 17 0	274	RS-BS1 SWGR1	pelēkmelna	5701132	6117 65 3	347				
OT3V GEKA80RW	dzidri balts / Alumīnijs	5145189	6287 17 0	277									
OT3V GEKA80RW	dzidri balts / Alumīnijs	5145189	6287 17 0	280	RT-BS1 AL1	alumīnija lakots	5405955	6117 65 8	347				
OT3V GEKA80RW	dzidri balts / Alumīnijs	5145189	6287 17 0	283	RT-BS1 RW1	dzidri balts	5405948	6117 65 7	347				
OT3V GEKA80RW	dzidri balts / Alumīnijs	5145189	6287 17 0	286	RT-BS1 SWGR1	pelēkmelna	5701149	6117 65 6	347				
OT3V GEKA80RW	dzidri balts / Alumīnijs	5145189	6287 17 0	289									
OT3V GEKA80RW	dzidri balts / Alumīnijs	5145189	6287 17 0	292	S990-AF1 AL	alumīnija lakots / PC	5405726	6107 00 8	355				
OT3V GEKA80RW	dzidri balts / Alumīnijs	5145189	6287 17 0	295	S990-AF1 RW	dzidri balts / PC	5120957	6107 00 2	355				
OT3V GEKA80RW	dzidri balts / Alumīnijs	5145189	6287 17 0	298	S990-AF2 AL	alumīnija lakots / PC	5405740	6107 10 8	355				
OT3V GEKA80RW	dzidri balts / Alumīnijs	5145189	6287 17 0	301	S990-AF2 RW	dzidri balts / PC	5121084	6107 10 2	355				
				€/gab.									
PAD-LQ6 AL1	alumīnija lakots	5406549	6119 99 9	349	S990-AF3 AL	alumīnija lakots / PC	5405764	6107 20 8	355				
PAD-LQ6 RW1	dzidri balts	5406532	6119 99 8	349	S990-AF3 RW	dzidri balts / PC	5121244	6107 20 2	355				
PAD-LQ6 SWGR1	pelēkmelna	5701507	6119 99 7	349	S990-AFB1 AL	alumīnija lakots / PC	5405733	6107 05 8	355				
				€/m									
PV N3 100H	100	5147176	6288 10 4	307	S990-AFB1 RW	dzidri balts / PC	5121022	6107 05 2	355				
PV N3 125H	125	5147183	6288 10 6	307	S990-AFB2 AL	alumīnija lakots / PC	5405757	6107 15 8	355				
PV N3 150H	150	5147213	6288 10 8	307	S990-AFB2 RW	dzidri balts / PC	5121183	6107 15 2	355				
PV N3 175H	175	5147220	6288 11 0	307	S990-AFB3 AL	alumīnija lakots / PC	5405771	6107 25 8	356				
PV N3 200H	200	5147237	6288 11 2	307	S990-AFB3 RW	dzidri balts / PC	5121305	6107 25 2	356				
PV N3 225H	225	5147244	6288 11 4	307	S990-AR1 AL	alumīnija lakots / PC	5273288	6107 07 8	356				
PV N3 250H	250	5147275	6288 11 6	307	S990-AR1 RW	dzidri balts / PC	5273240	6107 07 2	356				
PV N3 275H	275	5147282	6288 11 8	307	S990-AR2 AL	alumīnija lakots / PC	5273356	6107 17 8	356				
PV N3 300H	300	5147299	6288 12 0	307	S990-AR2 RW	dzidri balts / PC	5273349	6107 17 2	356				
PV N3 50H	50	5147152	6288 10 0	307	S990-AR3 AL	alumīnija lakots / PC	5273424	6107 27 8	356				
				€/m									
				€/gab.									
				€/m									
				€/gab.									
				€/m									
				€/gab.									
				€/m									
				€/gab.									
				€/m									
				€/gab.									
				€/m									
				€/gab.									
				€/m									
				€/gab.									
				€/m									
				€/gab.									
				€/m									
				€/gab.									
				€/m									
				€/gab.									
				€/m									
				€/gab.									
				€/m									
				€/gab.									
				€/m									
				€/gab.									
				€/m									
				€/gab.									

Tips	Izmērs/krāsa/cits	EAN-C.	Art.-Nr.	Cena	Lapa	Tips	Izmērs/krāsa/cits	EAN-C.	Art.-Nr.	Cena	Lapa		
SAISSF	/ gab. / VZ	5459279	6290 19 8	€/gab.	328	SKL-R DRW	dzidri balts / PVC	6156795	6199 40 2	€/gab.	161		
SAISSF	/ gab. / VZ	5459279	6290 19 8		330	SKL-SA50DBR	sēpijas brūna / PVC	6153978	6199 18 4		158		
SAISSF	/ gab. / VZ	5459279	6290 19 8		332	SKL-SA50DBU	dižskābarža / PVC	6154036	6199 18 6		158		
SE-B AL1	alumīnija lakots	5405894	6117 61 6	€/gab.	347	SKL-SA50DRW	dzidri balts / PVC	6153855	6199 18 0	€/gab.	158		
SE-B RW1	dzidri balts	5405887	6117 61 5		347	SKL-SA70DBR	sēpijas brūna / PVC	6156610	6199 28 5		160		
SE-B SWGR1	pelēkmelna	5700999	6117 61 4		347	SKL-SA70DBU	dižskābarža / PVC	6156672	6199 28 7		160		
SFISSFRW	dzidri balts / gab.	5459231	6290 19 6	€/m	328	SKL-SA70DCW	krēmbalta / PVC	6156498	6199 28 3	€/m	160		
SFISSFRW	dzidri balts / gab.	5459231	6290 19 6		330	SKL-SA70DRW	dzidri balts / PVC	6156559	6199 28 1		160		
SFISSFRW	dzidri balts / gab.	5459231	6290 19 6		332	SKL-Z DBR	sēpijas brūna / PVC	6158652	6199 44 6		159		
SFISSFWAL	balta alumīnija / gab.	5459248	6290 19 7		328	SKL-Z DBU	dižskābarža / PVC	6158713	6199 44 8		159		
SFISSFWAL	balta alumīnija / gab.	5459248	6290 19 7		330	SKL-Z DBU	dižskābarža / PVC	6158713	6199 44 8		161		
SFISSFWAL	balta alumīnija / gab.	5459248	6290 19 7		332	SKL-Z DCW	krēmbalta / PVC	6158294	6199 44 4		159		
							SKL-Z DCW	krēmbalta / PVC	6158294		6199 44 4		161
							SKL-Z DRW	dzidri balts / PVC	6157938		6199 44 2		159
							SKL-Z DRW	dzidri balts / PVC	6157938		6199 44 2		161
SG2545	/ gab.	6628278	6028 41 1		85								
SK2545	/ gab.	6628216	6028 40 3		85								
					€/m		SKS-CH0 RW1	dzidri balts / PC	5008866		6117 20 0	€/m	344
SKL-45 DBR	sēpijas brūna / PVC	6158898	6199 46 5			159	SKS-D0 AL1	alumīnija lakots / PC	6212774		6117 00 9		340
SKL-45 DBR	sēpijas brūna / PVC	6158898	6199 46 5	161		SKS-D0 AL2	alumīnija lakots / PC	6212835	6117 02 0	340			
SKL-45 DBU	dižskābarža / PVC	6158959	6199 46 7	159		SKS-D0 AL3	alumīnija lakots / PC	6213078	6117 03 1	341			
SKL-45 DBU	dižskābarža / PVC	6158959	6199 46 7	161		SKS-D0 MZGN1	piparmētru zaļa / PC	6458530	6117 00 5	340			
SKL-45 DCW	krēmbalta / PVC	6158836	6199 46 3	159		SKS-D0 MZGN2	piparmētru zaļa / PC	6458837	6117 01 6	340			
SKL-45 DCW	krēmbalta / PVC	6158836	6199 46 3	161		SKS-D0 MZGN3	piparmētru zaļa / PC	6458950	6117 02 7	341			
SKL-45 DRW	dzidri balts / PVC	6158775	6199 46 1	159		SKS-D0 ROR1	oranža / PC	6458356	6117 00 3	340			
SKL-45 DRW	dzidri balts / PVC	6158775	6199 46 1	161		SKS-D0 ROR2	oranža / PC	6458653	6117 01 4	340			
						SKS-D0 ROR3	oranža / PC	6645077	6117 02 5	341			
SKL-50DBR	sēpijas brūna 2000 / PVC	6096381	6199 10 7	158		SKS-D0 RW1	dzidri balts / PC	6458295	6117 00 1	340			
SKL-50DBU	dižskābarža 2000 / PVC	6096442	6199 10 9	158		SKS-D0 RW2	dzidri balts / PC	6518531	6117 01 2	340			
SKL-50DCW	krēmbalta 2000 / PVC	6096206	6199 10 5	158		SKS-D0 RW3	dzidri balts / PC	6458899	6117 02 3	341			
SKL-50DRW	dzidri balts 2000 / PVC	6096329	6199 10 3	158	SKS-D0 SRO1	signālsarkana / PC	6458592	6117 00 7	340				
SKL-70DBR	sēpijas brūna 2000 / PVC	6154210	6199 20 6	160	SKS-D0 SRO2	signālsarkana / PC	6471072	6117 01 8	340				
SKL-70DBU	dižskābarža 2000 / PVC	6154272	6199 20 8	160	SKS-D0 SRO3	signālsarkana / PC	6597376	6117 02 9	341				
SKL-70DCW	krēmbalta 2000 / PVC	6154159	6199 20 4	160	SKS-D0 SWGR1	pelēkmelna / PC	5700883	6117 00 8	340				
SKL-70DRW	dzidri balts 2000 / PVC	6154098	6199 20 2	160	SKS-D0 SWGR2	pelēkmelna / PC	5648956	6117 01 9	340				
					SKS-D0 SWGR3	pelēkmelna / PC	5700890	6117 03 0	341				
				€/gab.		SKS-D3 AL1	alumīnija lakots / PC	6213139	6117 04 9	€/gab.	341		
SKL-A50DBR	sēpijas brūna / PVC	6153251	6199 13 7		158	SKS-D3 AL2	alumīnija lakots / PC	6213191	6117 06 0		341		
SKL-A50DBU	dižskābarža / PVC	6153312	6199 13 9		158	SKS-D3 AL3	alumīnija lakots / PC	6213436	6117 07 1		341		
SKL-A50DCW	krēmbalta / PVC	6153190	6199 13 5		158	SKS-D3 MZGN1	piparmētru zaļa / PC	6459131	6117 04 5		341		
SKL-A50DRW	dzidri balts / PVC	6119615	6199 13 3		160	SKS-D3 MZGN2	piparmētru zaļa / PC	6459674	6117 05 6		341		
SKL-A70DBR	sēpijas brūna / PVC	6154692	6199 23 6		160	SKS-D3 MZGN3	piparmētru zaļa / PC	6459971	6117 06 7		341		
SKL-A70DBU	dižskābarža / PVC	6155774	6199 23 8		160	SKS-D3 ROR1	oranža / PC	6459070	6117 04 3		341		
SKL-A70DCW	krēmbalta / PVC	6154630	6199 23 4		160	SKS-D3 ROR2	oranža / PC	6459612	6117 05 4		341		
SKL-A70DRW	dzidri balts / PVC	6154579	6199 23 2		160	SKS-D3 ROR3	oranža / PC	6459858	6117 06 5		341		
SKL-DS DBR	sēpijas brūna / PVC	6157211	6199 42 5		159	SKS-D3 RW1	dzidri balts / PC	6459018	6117 04 1		341		
SKL-DS DBR	sēpijas brūna / PVC	6157211	6199 42 5		161	SKS-D3 RW2	dzidri balts / PC	6459551	6117 05 2		341		
SKL-DS DBU	dižskābarža / PVC	6157570	6199 42 7		159	SKS-D3 RW3	dzidri balts / PC	6459797	6117 06 3		341		
SKL-DS DBU	dižskābarža / PVC	6157570	6199 42 7		161	SKS-D3 SRO1	signālsarkana / PC	6459377	6117 04 7		341		
SKL-DS DCW	krēmbalta / PVC	6157099	6199 42 3	161	SKS-D3 SRO2	signālsarkana / PC	6459735	6117 05 8	341				
SKL-DS DCW	krēmbalta / PVC	6157099	6199 42 3	159	SKS-D3 SRO3	signālsarkana / PC	6460038	6117 06 9	341				
SKL-DS DRW	dzidri balts / PVC	6157037	6199 42 1	161	SKS-D3 SWGR1	pelēkmelna / PC	5700906	6117 04 8	341				
SKL-DS DRW	dzidri balts / PVC	6157037	6199 42 1	158	SKS-D3 SWGR2	pelēkmelna / PC	5700913	6117 05 9	341				
SKL-EL50DBR	sēpijas brūna / PVC	6153435	6199 15 4	158	SKS-D3 SWGR3	pelēkmelna / PC	5700920	6117 07 0	341				
SKL-EL50DBU	dižskābarža / PVC	6153558	6199 15 6	158									
SKL-EL50DCW	krēmbalta / PVC	6153374	6199 15 2	158	SKS-DK0 RW1	dzidri balts / PC	5462231	6117 20 2	344				
SKL-EL50DRW	dzidri balts / PVC	6153497	6199 15 0	160	SKS-DKE0 RW1	dzidri balts / PC	5616016	6117 20 3	344				
SKL-EL70DBR	sēpijas brūna / PVC	6155958	6199 25 5	160									
SKL-EL70DBU	dižskābarža / PVC	6156016	6199 25 7	160									
SKL-EL70DCW	krēmbalta / PVC	6155897	6199 25 3	160	SKS-DS3 AL2	alumīnija lakots / PC	5437987	6117 08 2	345				
SKL-EL70DRW	dzidri balts / PVC	6155835	6199 25 1	160	SKS-DS3 AL3	alumīnija lakots / PC	5670919	6119 86 0	345				
SKL-ER50DBR	sēpijas brūna / PVC	6153732	6199 16 7	158	SKS-DS3 MZGN2	piparmētru zaļa / PC	5437949	6117 07 8	345				
SKL-ER50DBU	dižskābarža / PVC	6153794	6199 16 9	158	SKS-DS3 MZGN3	piparmētru zaļa / PC	5670889	6119 85 4	345				
SKL-ER50DCW	krēmbalta / PVC	6153671	6199 16 5	158	SKS-DS3 ROR2	oranža / PC	5437932	6117 07 6	345				
SKL-ER50DRW	dzidri balts / PVC	6153619	6199 16 3	158	SKS-DS3 ROR3	oranža / PC	5670872	6119 85 2	345				
SKL-ER70DBR	sēpijas brūna / PVC	6156313	6199 26 6	160	SKS-DS3 RW2	dzidri balts / PC	5437925	6117 07 4	345				
SKL-ER70DBU	dižskābarža / PVC	6156375	6199 26 8	160	SKS-DS3 RW3	dzidri balts / PC	5670865	6119 85 0	345				
SKL-ER70DCW	krēmbalta / PVC	6156139	6199 26 4	160	SKS-DS3 SRO2	signālsarkana / PC	5437970	6117 08 0	345				
SKL-ER70DRW	dzidri balts / PVC	6156078	6199 26 2	160	SKS-DS3 SRO3	signālsarkana / PC	5670896	6119 85 6	345				
SKL-I50DBR	sēpijas brūna / PVC	6099993	6199 12 6	158	SKS-DS3 SWGR2	pelēkmelna / PC	5700937	6117 08 1	345				
SKL-I50DBU	dižskābarža / PVC	6100057	6199 12 8	158	SKS-DS3 SWGR3	pelēkmelna / PC	5670902	6119 85 8	345				
SKL-I50DCW	krēmbalta / PVC	6096268	6199 12 4	158	SKS-F0 AL1	alumīnija lakots / PC	6213498	6117 11 0	341				
SKL-I50DRW	dzidri balts / PVC	6096503	6199 12 2	158	SKS-F0 AL2	alumīnija lakots / PC	6213559	6117 11 9	342				
SKL-I70DBR	sēpijas brūna / PVC	6154456	6199 22 7	160	SKS-F0 AL3	alumīnija lakots / PC	6213795	6117 13 1	342				
SKL-I70DBU	dižskābarža / PVC	6154517	6199 22 9	160	SKS-F0 MZGN1	piparmētru zaļa / PC	6460212	6117 10 6	341				
SKL-I70DCW	krēmbalta / PVC	6154395	6199 22 5	160	SKS-F0 MZGN2	piparmētru zaļa / PC	6188956	6117 11 5	342				
SKL-I70DRW	dzidri balts / PVC	6154333	6199 22 3	160	SKS-F0 MZGN3	piparmētru zaļa / PC	6189373	6117 12 7	342				
SKL-R DBR	sēpijas brūna / PVC	6156856	6199 40 6	159	SKS-F0 ROR1	oranža / PC	6460151	6117 10 4	341				
SKL-R DBR	sēpijas brūna / PVC	6156856	6199 40 6	161	SKS-F0 ROR2	oranža / PC	6460458	6117 11 3	342				
SKL-R DBU	dižskābarža / PVC	6156979	6199 40 8	159	SKS-F0 ROR3	oranža / PC	6189311	6117 12 5	342				
SKL-R DBU	dižskābarža / PVC	6156979	6199 40 8	161	SKS-F0 RW1	dzidri balts / PC	6460090	6117 10 2	341				
SKL-R DCW	krēmbalta / PVC	6156733	6199 40 4	159	SKS-F0 RW2	dzidri balts / PC	6460335	6117 11 1	342				
SKL-R DCW	krēmbalta / PVC	6156733	6199 40 4	161	SKS-F0 RW3	dzidri balts / PC	6189076	6117 12 3	342				
SKL-R DRW	dzidri balts / PVC	6156795	6199 40 2	159	SKS-F0 SRO1	signālsarkana / PC	6460274	6117 10 8	341				

06 LFS\_Katalog\_2010\_Neuer\_Stand /lv / 12/07/2011 (LLEExport\_01304)

# Tipu saraksts

EAN numura uzbūve: valsts kods 40

ražotāja kods 1219 (art. numuriem, kas sākas ar 0: 1010)

individuālais EAN-C 5647589

Tips	Izmērs/krāsa/cits	EAN-C.	Art.-Nr.	Cena	Lapa	Tips	Izmērs/krāsa/cits	EAN-C.	Art.-Nr.	Cena	Lapa	
SKS-F0 SRO2	signālsarkana/ PC	6189014	6117 11 7	€/gab.	342	TW BR-A	gaiši pelēks/ PVC	6192670	6023 08 5	€/gab.	195	
SKS-F0 SRO3	signālsarkana/ PC	6189618	6117 12 9		342	TW BR-A	gaiši pelēks/ PVC	6192670	6023 08 5		202	
SKS-F0 SWGR1	pelēkmelna/ PC	5700944	6117 10 9		341	TW BR-A	gaiši pelēks/ PVC	6192670	6023 08 5		206	
SKS-F0 SWGR2	pelēkmelna/ PC	5433552	6117 11 8		342	TW BR-F	gaiši pelēks/ PVC	6192731	6023 08 9		189	
SKS-F0 SWGR3	pelēkmelna/ PC	5433569	6117 13 0		342	TW BR-F	gaiši pelēks/ PVC	6192731	6023 08 9		192	
SKS-F3 AL1	alumīnija lakots/ PC	6213856	6117 14 8		342	TW BR-F	gaiši pelēks/ PVC	6192731	6023 08 9		194	
SKS-F3 AL2	alumīnija lakots/ PC	6213917	6117 15 9		342	TW BR-F	gaiši pelēks/ PVC	6192731	6023 08 9		201	
SKS-F3 AL3	alumīnija lakots/ PC	6213979	6117 17 0		342	TW BR-F	gaiši pelēks/ PVC	6192731	6023 08 9		205	
SKS-F3 MZGN1	piparmētru zaļa/ PC	6287291	6117 14 4		342	TW BR-I	gaiši pelēks/ PVC	6192618	6023 08 1		189	
SKS-F3 MZGN2	piparmētru zaļa/ PC	6637218	6117 15 5		342	TW BR-I	gaiši pelēks/ PVC	6192618	6023 08 1		192	
SKS-F3 MZGN3	piparmētru zaļa/ PC	6461356	6117 16 6		342	TW BR-I	gaiši pelēks/ PVC	6192618	6023 08 1		195	
SKS-F3 ROR1	oranža/ PC	6189854	6117 14 2		342	TW BR-I	gaiši pelēks/ PVC	6192618	6023 08 1		201	
SKS-F3 ROR2	oranža/ PC	6538690	6117 15 3		342	TW BR-I	gaiši pelēks/ PVC	6192618	6023 08 1		205	
SKS-F3 ROR3	oranža/ PC	6461233	6117 16 4		342							
SKS-F3 RW1	dzidri balts/ PC	6189793	6117 14 0		342							
SKS-F3 RW2	dzidri balts/ PC	6460632	6117 15 1		342						€/m	
SKS-F3 RW3	dzidri balts/ PC	6461110	6117 16 2		342	TW ISS120	2000/ gab. / FS	5149521	6288 83 0			320
SKS-F3 SRO1	signālsarkana/ PC	6287536	6117 14 6		342						€/gab.	
SKS-F3 SRO2	signālsarkana/ PC	6461059	6117 15 7		342							
SKS-F3 SRO3	signālsarkana/ PC	6461530	6117 16 8		342	TWVRW	dzidri balts/ Alumīnijs	5162162	6290 24 0			324
SKS-F3 SWGR1	pelēkmelna/ PC	5700968	6117 14 7		342	TWVRW	dzidri balts/ Alumīnijs	5162162	6290 24 0			326
SKS-F3 SWGR2	pelēkmelna/ PC	5700975	6117 15 8		342							
SKS-F3 SWGR3	pelēkmelna/ PC	5700982	6117 16 9		342							
SKS-FC0 AL1	alumīnija lakots/ PC	5364191	6106 67 9	343					€/100 gab.			
SKS-FC0 AL2	alumīnija lakots/ PC	5364269	6106 68 9	343	ULS	pelēks 3/ PVC	6015061	6178 54 8		185		
SKS-FC0 AL3	alumīnija lakots/ PC	5364375	6106 69 9	343								
SKS-FC0 MZGN1	piparmētru zaļa/ PC	5364177	6106 67 5	343								
SKS-FC0 MZGN2	piparmētru zaļa/ PC	5364245	6106 68 5	343					€/gab.			
SKS-FC0 MZGN3	piparmētru zaļa/ PC	5364320	6106 69 5	343	ŪSM-A		5080886	5092 45 1		348		
SKS-FC0 ROR1	oranža/ PC	5364146	6106 67 3	343								
SKS-FC0 ROR2	oranža/ PC	5364238	6106 68 3	343								
SKS-FC0 ROR3	oranža/ PC	5364313	6106 69 3	343	ŪSS 45-A-ALU	alumīnija lakots	5006220	6117 46 7		348		
SKS-FC0 RW1	dzidri balts/ PC	5364139	6106 67 1	343	ŪSS 45-A-RW	dzidri balts	6117611	6117 46 5		348		
SKS-FC0 RW2	dzidri balts/ PC	5364207	6106 68 1	343	ŪSS 45-O-ALU	alumīnija lakots	5006213	6117 47 5		348		
SKS-FC0 RW3	dzidri balts/ PC	5364306	6106 69 1	343	ŪSS 45-O-RW	dzidri balts	6117673	6117 47 3		348		
SKS-FC0 SRO1	signālsarkana/ PC	5364184	6106 67 7	343								
SKS-FC0 SRO2	signālsarkana/ PC	5364252	6106 68 7	343	VB-SKS S	melns	5438113	6117 19 8		346		
SKS-FC0 SRO3	signālsarkana/ PC	5364368	6106 69 7	343								
SKS-FC3 AL1	alumīnija lakots/ PC	5364443	6106 70 9	343	WAG140100RRW	dzidri balts/ gab.	5648963	6290 29 0		329		
SKS-FC3 AL2	alumīnija lakots/ PC	5364535	6106 71 9	343	WAG140100RRW	dzidri balts/ gab.	5648963	6290 29 0		331		
SKS-FC3 AL3	alumīnija lakots/ PC	5364603	6106 72 9	344	WAG14022ARW	dzidri balts/ Alumīnijs	5162179	6290 25 0		327		
SKS-FC3 MZGN1	piparmētru zaļa/ PC	5364429	6106 70 5	343								
SKS-FC3 MZGN2	piparmētru zaļa/ PC	5364498	6106 71 5	343	WAG701400	dzidri balts/ gab.	5418566	6290 26 0		322		
SKS-FC3 MZGN3	piparmētru zaļa/ PC	5364566	6106 72 5	344	WAG70140TRW	dzidri balts/ gab.	5162063	6290 20 0		322		
SKS-FC3 ROR1	oranža/ PC	5364412	6106 70 3	343	WAG70140TRW	dzidri balts/ gab.	5162063	6290 20 0		324		
SKS-FC3 ROR2	oranža/ PC	5364481	6106 71 3	343								
SKS-FC3 ROR3	oranža/ PC	5364559	6106 72 3	344	WAG90110ARW	dzidri balts/ Alumīnijs	5162117	6290 22 0		325		
SKS-FC3 RW1	dzidri balts/ PC	5364382	6106 70 1	343								
SKS-FC3 RW2	dzidri balts/ PC	5364474	6106 71 1	343	WAGRM45	dzidri balts/ gab.	5428169	6290 26 4		328		
SKS-FC3 RW3	dzidri balts/ PC	5364542	6106 72 1	344								
SKS-FC3 SRO1	signālsarkana/ PC	5364436	6106 70 7	343								
SKS-FC3 SRO2	signālsarkana/ PC	5364504	6106 71 7	343	WDK HA100130CW	krēmbalta 170/ PVC	6107650	6161 15 4		118		
SKS-FC3 SRO3	signālsarkana/ PC	5364597	6106 72 7	344	WDK HA100130GR	akmens pelēks 170/ PVC	6027798	6024 58 0		118		
SKS-FS3 AL2	alumīnija lakots/ PC	5670995	6119 87 8	345	WDK HA100130LGR	gaiši pelēks 170/ PVC	6676996	6182 74 7		118		
SKS-FS3 AL3	alumīnija lakots/ PC	5671084	6119 89 0	345	WDK HA100130RW	dzidri balts 170/ PVC	5042600	6192 42 4		118		
SKS-FS3 MZGN2	piparmētru zaļa/ PC	5670964	6119 87 2	345	WDK HA10020CW	krēmbalta 30/ PVC	6099979	6153 29 1		86		
SKS-FS3 MZGN3	piparmētru zaļa/ PC	5671022	6119 88 4	345	WDK HA10020RW	dzidri balts 30/ PVC	6492015	6154 41 7		86		
SKS-FS3 ROR2	oranža/ PC	5670957	6119 87 0	345	WDK HA100230CW	krēmbalta 170/ PVC	6501854	6161 17 0		120		
SKS-FS3 ROR3	oranža/ PC	5671015	6119 88 2	345	WDK HA100230GR	akmens pelēks 170/ PVC	6501915	6024 68 8		120		
SKS-FS3 RW2	dzidri balts/ PC	5670926	6119 86 8	345	WDK HA100230LGR	gaiši pelēks 170/ PVC	6501793	6182 76 3		120		
SKS-FS3 RW3	dzidri balts/ PC	5671008	6119 88 0	345	WDK HA100230RW	dzidri balts 170/ PVC	5042693	6192 42 8		120		
SKS-FS3 SRO2	signālsarkana/ PC	5670971	6119 87 4	345	WDK HA10030CW	krēmbalta 30/ PVC	6804498	6153 30 5		88		
SKS-FS3 SRO3	signālsarkana/ PC	5671039	6119 88 6	345	WDK HA10030RW	dzidri balts 30/ PVC	6491537	6154 42 5		88		
SKS-FS3 SWGR2	pelēkmelna/ PC	5670988	6119 87 6	345	WDK HA15030CW	krēmbalta 38,5/ PVC	6579198	6160 61 1		91		
SKS-FS3 SWGR3	pelēkmelna/ PC	5671046	6119 88 8	345	WDK HA15030GR	akmens pelēks 38,5/ PVC	6579136	6158 35 8		91		
					WDK HA15030RW	dzidri balts 38,5/ PVC	6795253	6192 14 9		91		
SP3	/ gab. / FS	5680680	6279 80 0		307	WDK HA15040CW	krēmbalta 42/ PVC	6579372	6160 63 8		93	
						WDK HA15040GR	akmens pelēks 42/ PVC	6579310	6158 36 6		93	
STA-SKS S1 SW	melns	5438090	6117 19 2		345	WDK HA15040RW	dzidri balts 42/ PVC	6494712	6192 15 7		93	
STA-SKS S1 W	balts	5483571	6117 19 3		345	WDK HA20020CW	krēmbalta 38,5/ PVC	6579013	6160 60 3		95	
STA-SKS SU1 SW	melns	5670933	6117 19 6		346	WDK HA20020GR	akmens pelēks 38,5/ PVC	6578955	6158 33 1		95	
STA-SKS SU1 W	balts	5670940	6117 19 7		346	WDK HA20020LGR	gaiši pelēks 38,5/ PVC	6675197	6182 40 2		95	
						WDK HA20020RW	dzidri balts 38,5/ PVC	6795314	6192 16 5		95	
TA-B AL0.5	alumīnija lakots	5276050	6117 67 1		346	WDK HA20050CW	krēmbalta 45/ PVC	6507856	6153 37 2		97	
TA-B AL1	alumīnija lakots	5623816	6117 67 4		346	WDK HA20050RW	dzidri balts 45/ PVC	6493210	6154 46 8		97	
TA-B RW0.5	dzidri balts	5276043	6117 67 0		346	WDK HA25025CW	krēmbalta 50/ PVC	6579566	6160 64 6		99	
TA-B RW1	dzidri balts	5623809	6117 67 3		346	WDK HA25025GR	akmens pelēks 50/ PVC	6579495	6158 37 4		99	
TA-B SWGR0.5	pelēkmelna	5701156	6117 66 8		346	WDK HA25025LGR	gaiši pelēks 50/ PVC	6675258	6182 44 5		99	
TA-B SWGR1	pelēkmelna	5701323	6117 66 9		346	WDK HA25025RW	dzidri balts 50/ PVC	6504855	6192 17 3		99	
						WDK HA25040CW	krēmbalta 52/ PVC	6579730	6160 65 4		100	
TAE-6F AL1	alumīnija lakots	6215959	6117 43 0		349	WDK HA25040GR	akmens pelēks 52/ PVC	6579679	6158 38 2		100	
TAE-6F RW1	dzidri balts	6215713	6117 42 8		349	WDK HA25040RW	dzidri balts 52/ PVC	6795376	6192 18 1		100	
						WDK HA30030CW	krēmbalta 57/ PVC	6580095	6160 67 0		102	
						WDK HA30030GR	akmens pelēks 57/ PVC	6580033	6158 40 4		102	
TW BR-A	gaiši pelēks/ PVC	6192670	6023 08 5		189	WDK HA30030LGR	gaiši pelēks 57/ PVC	6675319	6182 48 8		102	
TW BR-A	gaiši pelēks/ PVC	6192670	6023 08 5		192	WDK HA30030RW	dzidri balts 57/ PVC	6795437	6192 21 1		102	

06 LFS\_Katalog\_2010\_Neuer\_Stand /lv / 12/07/2011 (LLEExport\_01304)

Tips	Izmērs/krāsa/cits	EAN-C.	Art.-Nr.	Cena	Lapa	Tips	Izmērs/krāsa/cits	EAN-C.	Art.-Nr.	Cena	Lapa
				€/gab.						€/gab.	
WDK HA30045CW	krēmbalta 57/ PVC	6641598	6160 68 9		103	WDK HE20035CW	krēmbalta 35/ PVC	6643219	6162 48 7		96
WDK HA30045GR	akmens pelēks 57/ PVC	6641536	6158 42 0		103	WDK HE20035GR	akmens pelēks 35/ PVC	6643158	6158 78 1		96
WDK HA30045LGR	gaiši pelēks 57/ PVC	6675371	6182 49 6		103	WDK HE20035LGR	gaiši pelēks 35/ PVC	6674053	6183 65 4		96
WDK HA30045RW	dzidri balts 57/ PVC	6497171	6192 23 8		103	WDK HE20035RW	dzidri balts 35/ PVC	6976768	6193 13 7		96
WDK HA40040CW	krēmbalta 66/ PVC	6580279	6160 69 7		104	WDK HE20050CW	krēmbalta 50/ PVC	6507672	6153 67 4		98
WDK HA40040GR	akmens pelēks 66/ PVC	6580217	6158 41 2		104	WDK HE20050GR	akmens pelēks 50/ PVC	6493395	6154 55 7		98
WDK HA40040LGR	gaiši pelēks 66/ PVC	6675432	6182 52 6		104	WDK HE25025CW	krēmbalta 25/ PVC	6583812	6162 53 3		99
WDK HA40040RW	dzidri balts 66/ PVC	6795499	6192 24 6		104	WDK HE25025GR	akmens pelēks 25/ PVC	6434657	6158 73 0		99
WDK HA40060CW	krēmbalta 100/ PVC	6106813	6160 70 0		105	WDK HE25025LGR	gaiši pelēks 25/ PVC	6674114	6183 66 2		99
WDK HA40060GR	akmens pelēks 100/ PVC	6019212	6021 69 7		105	WDK HE25025RW	dzidri balts 25/ PVC	6504794	6193 14 5		99
WDK HA40060LGR	gaiši pelēks 100/ PVC	6675494	6182 53 4		105	WDK HE25040CW	krēmbalta 40/ PVC	6583935	6162 54 1		101
WDK HA40060RW	dzidri balts 100/ PVC	6795550	6192 25 4		105	WDK HE25040GR	akmens pelēks 40/ PVC	6434718	6158 74 9		101
WDK HA40090CW	krēmbalta 100/ PVC	6106875	6160 71 9		106	WDK HE25040RW	dzidri balts 40/ PVC	6797356	6193 15 3		101
WDK HA40090GR	akmens pelēks 100/ PVC	6017171	6021 09 3		106	WDK HE30030CW	krēmbalta 30/ PVC	6584239	6162 57 6		102
WDK HA40090LGR	gaiši pelēks 100/ PVC	6675555	6182 54 2		106	WDK HE30030GR	akmens pelēks 30/ PVC	6584178	6158 76 5		102
WDK HA40090RW	dzidri balts 100/ PVC	6795611	6192 26 2		106	WDK HE30030LGR	gaiši pelēks 30/ PVC	6674176	6183 69 7		102
WDK HA40110CW	krēmbalta 100/ PVC	6106936	6160 72 7		107	WDK HE30030RW	dzidri balts 30/ PVC	6797417	6193 18 8		102
WDK HA40110GR	akmens pelēks 100/ PVC	6019274	6021 70 0		107	WDK HE30045CW	krēmbalta 45/ PVC	6641239	6162 58 4		103
WDK HA40110LGR	gaiši pelēks 100/ PVC	6675616	6182 55 0		107	WDK HE30045GR	akmens pelēks 45/ PVC	6434831	6158 80 3		103
WDK HA40110RW	dzidri balts 100/ PVC	6220878	6192 27 0		107	WDK HE30045LGR	gaiši pelēks 45/ PVC	6674237	6183 70 0		103
WDK HA60060CW	krēmbalta 100/ PVC	6107179	6160 90 5		108	WDK HE30045RW	dzidri balts 45/ PVC	6497355	6193 19 6		103
WDK HA60060GR	akmens pelēks 100/ PVC	6020539	6022 07 3		108	WDK HE40040CW	krēmbalta 40/ PVC	6583331	6162 59 2		104
WDK HA60060LGR	gaiši pelēks 100/ PVC	6676392	6182 59 3		108	WDK HE40040GR	akmens pelēks 40/ PVC	6583270	6158 77 3		104
WDK HA60060RW	dzidri balts 100/ PVC	6360970	6192 31 9		108	WDK HE40040LGR	gaiši pelēks 40/ PVC	6674299	6183 72 7		104
WDK HA60090CW	krēmbalta 100/ PVC	6107230	6160 91 3		109	WDK HE40040RW	dzidri balts 40/ PVC	6712939	6193 21 8		104
WDK HA60090GR	akmens pelēks 100/ PVC	6020713	6022 11 1		109	WDK HE40060CW	krēmbalta 60/ PVC	6109517	6162 60 6		105
WDK HA60090LGR	gaiši pelēks 100/ PVC	6676453	6182 60 7		109	WDK HE40060GR	akmens pelēks 60/ PVC	6018857	6021 49 2		105
WDK HA60090RW	dzidri balts 100/ PVC	6801558	6192 32 7		109	WDK HE40060LGR	gaiši pelēks 60/ PVC	6674350	6183 73 5		105
WDK HA60110CW	krēmbalta 100/ PVC	6107292	6160 92 1		111	WDK HE40060RW	dzidri balts 60/ PVC	6797479	6193 22 6		105
WDK HA60110GR	akmens pelēks 100/ PVC	6020836	6022 14 6		111	WDK HE40090CW	krēmbalta 90/ PVC	6109579	6162 61 4		106
WDK HA60110LGR	gaiši pelēks 100/ PVC	6676514	6182 61 5		111	WDK HE40090GR	akmens pelēks 90/ PVC	6018918	6021 50 6		106
WDK HA60110RW	dzidri balts 100/ PVC	6354559	6192 33 5		111	WDK HE40090LGR	gaiši pelēks 90/ PVC	6674411	6183 74 3		106
WDK HA60130CW	krēmbalta 100/ PVC	6107353	6160 94 8		112	WDK HE40090RW	dzidri balts 90/ PVC	6797530	6193 23 4		106
WDK HA60130GR	akmens pelēks 100/ PVC	6020959	6022 16 2		112	WDK HE40110CW	krēmbalta 110/ PVC	6109630	6162 62 2		107
WDK HA60130LGR	gaiši pelēks 100/ PVC	6676576	6182 62 3		112	WDK HE40110GR	akmens pelēks 110/ PVC	6018970	6021 51 4		107
WDK HA60130RW	dzidri balts 100/ PVC	6353057	6192 34 3		112	WDK HE40110LGR	gaiši pelēks 110/ PVC	6674473	6183 75 1		107
WDK HA60150CW	krēmbalta 100/ PVC	6638352	6160 97 2		113	WDK HE40110RW	dzidri balts 110/ PVC	6974788	6193 24 2		107
WDK HA60150GR	akmens pelēks 100/ PVC	6638291	6024 52 1		113	WDK HE60060CW	krēmbalta 60/ PVC	6109876	6162 80 0		108
WDK HA60150LGR	gaiši pelēks 100/ PVC	6676637	6182 63 1		113	WDK HE60060GR	akmens pelēks 60/ PVC	6022694	6022 49 9		108
WDK HA60150RW	dzidri balts 100/ PVC	6492312	6192 35 1		113	WDK HE60060LGR	gaiši pelēks 60/ PVC	6678372	6183 80 8		108
WDK HA60170CW	krēmbalta 100/ PVC	6107414	6160 95 6		114	WDK HE60060RW	dzidri balts 60/ PVC	6712991	6193 28 5		108
WDK HA60170GR	akmens pelēks 100/ PVC	6021079	6022 18 9		114	WDK HE60090CW	krēmbalta 90/ PVC	6109937	6162 81 9		109
WDK HA60170LGR	gaiši pelēks 100/ PVC	6676699	6182 65 8		114	WDK HE60090GR	akmens pelēks 90/ PVC	6022755	6022 50 2		109
WDK HA60170RW	dzidri balts 100/ PVC	6351855	6192 37 8		114	WDK HE60090LGR	gaiši pelēks 90/ PVC	6678433	6183 81 6		109
WDK HA60210CW	krēmbalta 100/ PVC	6107476	6160 96 4		115	WDK HE60090RW	dzidri balts 90/ PVC	6492794	6193 29 3		109
WDK HA60210GR	akmens pelēks 100/ PVC	6021130	6022 19 7		115	WDK HE60110CW	krēmbalta 110/ PVC	6109999	6162 82 7		111
WDK HA60210LGR	gaiši pelēks 100/ PVC	6676750	6182 66 6		115	WDK HE60110GR	akmens pelēks 110/ PVC	6022991	6022 58 8		111
WDK HA60210RW	dzidri balts 100/ PVC	6795673	6192 38 6		115	WDK HE60110LGR	gaiši pelēks 110/ PVC	6678495	6183 82 4		111
WDK HA60230CW	krēmbalta 100/ PVC	6639731	6160 98 0		110	WDK HE60110RW	dzidri balts 110/ PVC	6713059	6193 30 7		111
WDK HA60230GR	akmens pelēks 100/ PVC	6639670	6024 54 8		110	WDK HE60130CW	krēmbalta 130/ PVC	6110056	6162 83 5		112
WDK HA60230LGR	gaiši pelēks 100/ PVC	6676811	6182 67 4		110	WDK HE60130GR	akmens pelēks 130/ PVC	6022816	6022 52 9		112
WDK HA60230RW	dzidri balts 100/ PVC	6492374	6192 39 4		110	WDK HE60130LGR	gaiši pelēks 130/ PVC	6678556	6183 83 2		112
WDK HA80170CW	krēmbalta 150/ PVC	6107537	6161 10 3		119	WDK HE60130RW	dzidri balts 130/ PVC	6713110	6193 31 5		112
WDK HA80170GR	akmens pelēks 150/ PVC	6027675	6024 56 4		119	WDK HE60150CW	krēmbalta 150/ PVC	6637997	6162 87 8		113
WDK HA80170LGR	gaiši pelēks 150/ PVC	6676873	6182 71 2		119	WDK HE60150GR	akmens pelēks 150/ PVC	6637935	6024 82 3		113
WDK HA80170RW	dzidri balts 150/ PVC	5042464	6192 41 6		119	WDK HE60150LGR	gaiši pelēks 150/ PVC	6678617	6183 84 0		113
WDK HA80210CW	krēmbalta 150/ PVC	6107599	6161 11 1		117	WDK HE60150RW	dzidri balts 150/ PVC	6492855	6193 32 3		113
WDK HA80210GR	akmens pelēks 150/ PVC	6027736	6024 57 2		117	WDK HE60170CW	krēmbalta 170/ PVC	6110117	6162 84 3		114
WDK HA80210LGR	gaiši pelēks 150/ PVC	6676934	6182 72 0		117	WDK HE60170GR	akmens pelēks 170/ PVC	6022878	6022 54 5		114
WDK HA80210RW	dzidri balts 150/ PVC	6504532	6192 42 0		117	WDK HE60170LGR	gaiši pelēks 170/ PVC	6678679	6183 85 9		114
WDK HE100130CW	krēmbalta 150/ PVC	6110353	6163 04 1		118	WDK HE60170RW	dzidri balts 170/ PVC	6713172	6193 33 1		114
WDK HE100130GR	akmens pelēks 150/ PVC	6028337	6024 88 2		118	WDK HE60210CW	krēmbalta 210/ PVC	6110179	6162 85 1		116
WDK HE100130LGR	gaiši pelēks 150/ PVC	6678976	6183 95 6		118	WDK HE60210GR	akmens pelēks 210/ PVC	6022939	6022 56 1		116
WDK HE100130RW	dzidri balts 150/ PVC	5042655	6193 39 5		118	WDK HE60210LGR	gaiši pelēks 210/ PVC	6678730	6183 86 7		116
WDK HE10020CW	krēmbalta 22/ PVC	6100392	6153 59 3		87	WDK HE60210RW	dzidri balts 210/ PVC	6797592	6193 35 8		116
WDK HE10020RW	dzidri balts 22/ PVC	6491834	6154 51 4		87	WDK HE60230CW	krēmbalta 230/ PVC	6639373	6162 88 6		110
WDK HE100230CRW	krēmbalta 230/ PVC	6651436	6163 07 6		120	WDK HE60230GR	akmens pelēks 230/ PVC	6639311	6024 83 1		110
WDK HE100230GR	akmens pelēks 230/ PVC	6651375	6024 90 4		120	WDK HE60230LGR	gaiši pelēks 230/ PVC	6678792	6183 87 5		110
WDK HE100230LGR	gaiši pelēks 230/ PVC	6679034	6183 98 0		120	WDK HE60230RW	dzidri balts 230/ PVC	6492916	6193 36 6		110
WDK HE100230RW	dzidri balts 230/ PVC	5042723	6193 39 9		120	WDK HE80170CW	krēmbalta 150/ PVC	6110230	6163 00 9		119
WDK HE10030CW	krēmbalta 32/ PVC	6100453	6153 60 7		89	WDK HE80170GR	akmens pelēks 150/ PVC	6028214	6024 85 8		119
WDK HE10030CW	krēmbalta 17/ PVC	6583454	6162 50 9		95	WDK HE80170LGR	gaiši pelēks 150/ PVC	6678853	6183 91 3		119
WDK HE10030GR	akmens pelēks 17/ PVC	6434473	6158 70 6		95	WDK HE80170RW	dzidri balts 150/ PVC	5042518	6193 38 7		119
WDK HE10030RW	dzidri balts 32/ PVC	6491353	6154 52 2		89	WDK HE80210CW	krēmbalta 150/ PVC	6110292	6163 01 7		117
WDK HE15015CW	krēmbalta 15/ PVC	6642670	6162 49 5		90	WDK HE80210GR	akmens pelēks 150/ PVC	6028276	6024 87 4		117
WDK HE15015GR	akmens pelēks 15/ PVC	6642618	6158 69 2		90	WDK HE80210LGR	gaiši pelēks 150/ PVC	6678914	6183 92 1		117
WDK HE15015LGR	gaiši pelēks 15/ PVC	6673933	6183 60 3		90	WDK HE80210RW	dzidri balts 150/ PVC	5042587	6193 39 1		117
WDK HE15015RW	dzidri balts 15/ PVC	6797172	6193 09 9		90	WDK HF100130CW	krēmbalta 166/ PVC	6108558	6161 75 8		118
WDK HE15030CW	krēmbalta 30/ PVC	6583577	6162 51 7		92	WDK HF100130GR	akmens pelēks 166/ PVC	6027972	6024 63 7		118
WDK HE15030GR	akmens pelēks 30/ PVC	6434534	6158 71 4		92	WDK HF100130LGR	gaiši pelēks 166/ PVC	6678310	6183 55 7		118
WDK HE15030RW	dzidri balts 30/ PVC	6797233	6193 10 2		92	WDK HF100130RW	dzidri balts 166/ PVC	5042648	6193 02 9		118
WDK HE15040CW	krēmbalta 40/ PVC	6583690	6162 52 5		94	WDK HF10020CW	krēmbalta 40/ PVC	6099139	6152 60 0		86
WDK HE15040GR	akmens pelēks 40/ PVC	6434596	6158 72 2		94	WDK HF10020RW	dzidri balts 40/ PVC	6491896	6154 21 2		86
WDK HE15040RW	dzidri balts 40/ PVC	6975624	6193 11 0		94	WDK HF100230CW	krēmbalta 266/ PVC	6501250	6161 77 4		120
WDK HE20020LGR	gaiši pelēks 17/ PVC	6673995	6183 61 1		95	WDK HF100230GR	akmens pelēks 266/ PVC	6501311	6024 65 3		120
WDK HE20020RW	dzidri balts 17/ PVC	6797295	6193 12 9		95	WDK HF100230LGR	gaiši pelēks 266/ PVC	6222131	6183 57 3		120

06\_LFS\_Katalog\_2010\_Neuer\_Stand /lv/ 12/07/2011 (LLExpert\_

# Tipu saraksts

EAN numura uzbūve: valsts kods 40

ražotāja kods 1219 (art. numuriem, kas sākas ar 0: 1010)

individuālais EAN-C 5647589

Tips	Izmērs/krāsa/cits	EAN-C.	Art.-Nr.	Cena	Lapa	Tips	Izmērs/krāsa/cits	EAN-C.	Art.-Nr.	Cena	Lapa
				€/gab.						€/gab.	
WDK HF100230RW	dzidri balts 266 / PVC	5042716	6193 03 3		120	WDK HI100130CW	krēmbalta 170 / PVC	6106752	6160 52 2		118
WDK HF10030CW	krēmbalta 50 / PVC	6099191	6152 61 9		88	WDK HI100130GR	akmens pelēks 170 / PVC	6027613	6024 48 3		118
WDK HF10030RW	dzidri balts 50 / PVC	6491414	6154 22 0		88	WDK HI100130LGR	gaiši pelēks 170 / PVC	6676330	6182 34 8		118
WDK HF15030CW	krēmbalta 53 / PVC	6582075	6161 21 9		91	WDK HI100130RW	dzidri balts 170 / PVC	5042594	6192 11 4		118
WDK HF15030GR	akmens pelēks 53 / PVC	6582013	6158 59 5		91	WDK HI10020CW	krēmbalta 30 / PVC	6099559	6153 00 3		86
WDK HF15030RW	dzidri balts 53 / PVC	6796694	6192 75 0		91	WDK HI10020RW	dzidri balts 30 / PVC	6492077	6154 32 8		86
WDK HF15040CW	krēmbalta 63 / PVC	6582259	6161 22 7		93	WDK HI100230CW	krēmbalta 170 / PVC	6502035	6160 54 9		120
WDK HF15040GR	akmens pelēks 63 / PVC	6582198	6158 60 9		93	WDK HI100230GR	akmens pelēks 170 / PVC	6502097	6024 50 5		120
WDK HF15040RW	dzidri balts 63 / PVC	6494835	6192 76 9		93	WDK HI100230LGR	gaiši pelēks 170 / PVC	6501977	6182 36 4		120
WDK HF20020CW	krēmbalta 38 / PVC	6581894	6161 20 0		95	WDK HI100230RW	dzidri balts 170 / PVC	5042662	6192 11 8		120
WDK HF20020GR	akmens pelēks 38 / PVC	6581832	6158 58 7		95	WDK HI10030CW	krēmbalta 30 / PVC	6099610	6153 01 1		88
WDK HF20020LGR	gaiši pelēks 38 / PVC	6673391	6183 21 2		95	WDK HI10030RW	dzidri balts 30 / PVC	6491599	6154 33 6		88
WDK HF20020RW	dzidri balts 38 / PVC	6796755	6192 77 7		95	WDK HI15030CW	krēmbalta 38,5 / PVC	6577811	6160 02 6		91
WDK HF20050CW	krēmbalta 73 / PVC	6507733	6152 68 6		97	WDK HI15030GR	akmens pelēks 38,5 / PVC	6577750	6158 23 4		91
WDK HF20050RW	dzidri balts 73 / PVC	6493333	6154 25 5		97	WDK HI15030RW	dzidri balts 38,5 / PVC	6794652	6191 84 3		91
WDK HF25025CW	krēmbalta 48 / PVC	6582433	6161 23 5		99	WDK HI15040CW	krēmbalta 42 / PVC	6577996	6160 03 4		93
WDK HF25025GR	akmens pelēks 48 / PVC	6582372	6158 61 7		99	WDK HI15040GR	akmens pelēks 42 / PVC	6577934	6158 24 2		93
WDK HF25025LGR	gaiši pelēks 48 / PVC	6673452	6183 25 5		99	WDK HI15040RW	dzidri balts 42 / PVC	6494651	6191 85 1		93
WDK HF25025RW	dzidri balts 48 / PVC	6504916	6192 78 5		99	WDK HI20020CW	krēmbalta 38,5 / PVC	6577637	6160 01 8		95
WDK HF25040CW	krēmbalta 63 / PVC	6582617	6161 24 3		100	WDK HI20020GR	akmens pelēks 38,5 / PVC	6577576	6158 22 6		95
WDK HF25040GR	akmens pelēks 63 / PVC	6582556	6158 62 5		100	WDK HI20020LGR	gaiši pelēks 38,5 / PVC	6674657	6182 01 1		95
WDK HF25040RW	dzidri balts 63 / PVC	6796816	6192 79 3		100	WDK HI20020RW	dzidri balts 38,5 / PVC	6794713	6191 87 8		95
WDK HF30030CW	krēmbalta 53 / PVC	6582976	6161 27 8		102	WDK HI20050CW	krēmbalta 45 / PVC	6507917	6153 08 9		97
WDK HF30030GR	akmens pelēks 53 / PVC	6582914	6158 64 1		102	WDK HI20050RW	dzidri balts 45 / PVC	6974542	6154 36 0		97
WDK HF30030LGR	gaiši pelēks 53 / PVC	6673513	6183 29 8		102	WDK HI25025CW	krēmbalta 50 / PVC	6578177	6160 04 2		99
WDK HF30030RW	dzidri balts 53 / PVC	6796878	6192 81 5		102	WDK HI25025GR	akmens pelēks 50 / PVC	6578115	6158 25 0		99
WDK HF30045CW	krēmbalta 68 / PVC	6641772	6161 28 6		103	WDK HI25025LGR	gaiši pelēks 50 / PVC	6674718	6182 06 2		99
WDK HF30045GR	akmens pelēks 68 / PVC	6641710	6158 67 6		103	WDK HI25025RW	dzidri balts 50 / PVC	6502219	6191 88 6		99
WDK HF30045LGR	gaiši pelēks 68 / PVC	6673575	6183 30 1		103	WDK HI25040CW	krēmbalta 50 / PVC	6578351	6160 05 0		100
WDK HF30045RW	dzidri balts 68 / PVC	6497294	6192 82 3		103	WDK HI25040GR	akmens pelēks 50 / PVC	6578290	6158 26 9		100
WDK HF40040CW	krēmbalta 63 / PVC	6583157	6161 29 4		104	WDK HI25040RW	dzidri balts 50 / PVC	6794775	6191 89 4		100
WDK HF40040GR	akmens pelēks 63 / PVC	6583096	6158 66 8		104	WDK HI30030CW	krēmbalta 52 / PVC	6578719	6160 07 4		102
WDK HF40040LGR	gaiši pelēks 63 / PVC	6673636	6183 33 6		104	WDK HI30030GR	akmens pelēks 52 / PVC	6578658	6158 28 5		102
WDK HF40040RW	dzidri balts 63 / PVC	6796939	6192 83 1		104	WDK HI30030LGR	gaiši pelēks 52 / PVC	6674770	6182 09 7		102
WDK HF40060CW	krēmbalta 101 / PVC	6107711	6161 30 8		105	WDK HI30030RW	dzidri balts 52 / PVC	6794836	6191 92 4		102
WDK HF40060GR	akmens pelēks 101 / PVC	6019458	6021 73 5		105	WDK HI30045CW	krēmbalta 52 / PVC	6641413	6160 08 5		103
WDK HF40060LGR	gaiši pelēks 101 / PVC	6673698	6183 34 4		105	WDK HI30045GR	akmens pelēks 52 / PVC	6641352	6158 30 7		103
WDK HF40060RW	dzidri balts 101 / PVC	6796991	6192 85 8		105	WDK HI30045LGR	gaiši pelēks 52 / PVC	6674831	6182 10 0		103
WDK HF40090CW	krēmbalta 129 / PVC	6107773	6161 31 6		106	WDK HI30045RW	dzidri balts 52 / PVC	6976829	6191 93 2		103
WDK HF40090GR	akmens pelēks 129 / PVC	6018253	6021 33 6		106	WDK HI40040CW	krēmbalta 65 / PVC	6584598	6160 09 3		104
WDK HF40090LGR	gaiši pelēks 129 / PVC	6673759	6183 35 2		106	WDK HI40040GR	akmens pelēks 65 / PVC	6578832	6158 29 3		104
WDK HF40090RW	dzidri balts 129 / PVC	6797059	6192 86 6		106	WDK HI40040LGR	gaiši pelēks 65 / PVC	6674893	6182 11 9		104
WDK HF40110CW	krēmbalta 110 / PVC	6107834	6161 32 4		107	WDK HI40040RW	dzidri balts 65 / PVC	6794898	6191 94 0		104
WDK HF40110GR	akmens pelēks 110 / PVC	6019519	6021 74 3		107	WDK HI40060CW	krēmbalta 110 / PVC	6105915	6160 10 7		105
WDK HF40110LGR	gaiši pelēks 110 / PVC	6673810	6183 36 0		107	WDK HI40060GR	akmens pelēks 110 / PVC	6019335	6021 71 9		105
WDK HF40110RW	dzidri balts 110 / PVC	6496990	6192 87 4		107	WDK HI40060LGR	gaiši pelēks 110 / PVC	6674954	6182 12 7		105
WDK HF60060CW	krēmbalta 101 / PVC	6108077	6161 50 2		108	WDK HI40060RW	dzidri balts 110 / PVC	6794959	6191 95 9		105
WDK HF60060GR	akmens pelēks 101 / PVC	6022519	6022 44 8		108	WDK HI40090CW	krēmbalta 109 / PVC	6105977	6160 11 5		106
WDK HF60060LGR	gaiši pelēks 101 / PVC	6677719	6183 40 9		108	WDK HI40090GR	akmens pelēks 109 / PVC	6017652	6021 19 0		106
WDK HF60060RW	dzidri balts 101 / PVC	6712694	6192 91 2		108	WDK HI40090LGR	gaiši pelēks 109 / PVC	6675012	6182 13 5		106
WDK HF60090CW	krēmbalta 129 / PVC	6108138	6161 51 0		109	WDK HI40090RW	dzidri balts 109 / PVC	6795017	6191 96 7		106
WDK HF60090GR	akmens pelēks 129 / PVC	6021796	6022 31 6		109	WDK HI40110CW	krēmbalta 110,5 / PVC	6106035	6160 12 3		107
WDK HF60090LGR	gaiši pelēks 129 / PVC	6677771	6183 41 7		109	WDK HI40110GR	akmens pelēks 110,5 / PVC	6019397	6021 72 7		107
WDK HF60090RW	dzidri balts 129 / PVC	6492619	6192 92 0		109	WDK HI40110LGR	gaiši pelēks 110,5 / PVC	6675074	6182 14 3		107
WDK HF60110CW	krēmbalta 149 / PVC	6108190	6161 52 9		111	WDK HI40110RW	dzidri balts 110,5 / PVC	6221110	6191 97 5		107
WDK HF60110GR	akmens pelēks 149 / PVC	6021918	6022 33 2		111	WDK HI60060CW	krēmbalta 130 / PVC	6106271	6160 30 1		108
WDK HF60110LGR	gaiši pelēks 149 / PVC	6677832	6183 42 5		111	WDK HI60060GR	akmens pelēks 130 / PVC	6022212	6022 38 3		108
WDK HF60110RW	dzidri balts 149 / PVC	6712755	6192 93 9		111	WDK HI60060LGR	gaiši pelēks 130 / PVC	6675739	6182 19 4		108
WDK HF60130CW	krēmbalta 170 / PVC	6108251	6161 53 7		112	WDK HI60060RW	dzidri balts 130 / PVC	6362950	6192 01 7		108
WDK HF60130GR	akmens pelēks 170 / PVC	6022038	6022 35 9		112	WDK HI60090CW	krēmbalta 130 / PVC	6106332	6160 32 8		109
WDK HF60130LGR	gaiši pelēks 170 / PVC	6677894	6183 43 3		112	WDK HI60090GR	akmens pelēks 130 / PVC	6021253	6022 21 9		109
WDK HF60130RW	dzidri balts 170 / PVC	6712816	6192 94 7		112	WDK HI60090LGR	gaiši pelēks 130 / PVC	6675791	6182 20 5		109
WDK HF60150CW	krēmbalta 190 / PVC	6638536	6161 56 1		113	WDK HI60090RW	dzidri balts 130 / PVC	6799879	6192 02 8		109
WDK HF60150GR	akmens pelēks 190 / PVC	6638475	6024 59 9		113	WDK HI60110CW	krēmbalta 130 / PVC	6106394	6160 33 6		111
WDK HF60150LGR	gaiši pelēks 190 / PVC	6677955	6183 44 1		113	WDK HI60110GR	akmens pelēks 130 / PVC	6021376	6022 23 5		111
WDK HF60150RW	dzidri balts 190 / PVC	6492671	6192 95 5		113	WDK HI60110LGR	gaiši pelēks 130 / PVC	6675852	6182 21 6		111
WDK HF60170CW	krēmbalta 211 / PVC	6108312	6161 54 5		114	WDK HI60110RW	dzidri balts 130 / PVC	6362776	6192 03 3		111
WDK HF60170GR	akmens pelēks 211 / PVC	6022151	6022 37 5		114	WDK HI60130CW	krēmbalta 130 / PVC	6106455	6160 34 4		112
WDK HF60170LGR	gaiši pelēks 211 / PVC	6678013	6183 46 8		114	WDK HI60130GR	akmens pelēks 130 / PVC	6021499	6022 25 1		112
WDK HF60170RW	dzidri balts 211 / PVC	6712878	6192 96 3		114	WDK HI60130LGR	gaiši pelēks 130 / PVC	6675913	6182 22 4		112
WDK HF60210CW	krēmbalta 250 / PVC	6108374	6161 55 3		115	WDK HI60130RW	dzidri balts 130 / PVC	6362479	6192 04 1		112
WDK HF60210GR	akmens pelēks 250 / PVC	6022274	6022 39 1		115	WDK HI60150CW	krēmbalta 130 / PVC	6638178	6160 37 9		113
WDK HF60210LGR	gaiši pelēks 250 / PVC	6678075	6183 47 6		115	WDK HI60150GR	akmens pelēks 130 / PVC	6638116	6024 43 2		113
WDK HF60210RW	dzidri balts 250 / PVC	6797110	6192 97 1		115	WDK HI60150LGR	gaiši pelēks 130 / PVC	6675975	6182 23 2		113
WDK HF60230CW	krēmbalta 270 / PVC	6639915	6161 59 6		110	WDK HI60150RW	dzidri balts 130 / PVC	6800056	6192 06 8		113
WDK HF60230GR	akmens pelēks 270 / PVC	6639854	6024 60 2		110	WDK HI60170CW	krēmbalta 130 / PVC	6106516	6160 35 2		114
WDK HF60230LGR	gaiši pelēks 270 / PVC	6678136	6183 48 4		110	WDK HI60170GR	akmens pelēks 130 / PVC	6021611	6022 28 6		114
WDK HF60230RW	dzidri balts 270 / PVC	6492732	6192 99 8		110	WDK HI60170LGR	gaiši pelēks				

Tips	Izmērs/krāsa/cits	EAN-C.	Art.-Nr.	Cena	Lapa	Tips	Izmērs/krāsa/cits	EAN-C.	Art.-Nr.	Cena	Lapa		
WDK HI60230RW	dzidri balts 130/ PVC	6800896	6192 09 2	€/gab.	110	WDK HT10030CW	krēmbalta 55/ PVC	6098774	6152 31 7	€/gab.	88		
WDK HI80170CW	krēmbalta 150/ PVC	6106639	6160 48 4		119	WDK HT10030RW	dzidri balts 55/ PVC	6491476	6154 12 3		88		
WDK HI80170GR	akmens pelēks 150/ PVC	6027491	6024 46 7		119	WDK HT15030CW	krēmbalta 73/ PVC	6580637	6161 92 8		92		
WDK HI80170LGR	gaiši pelēks 150/ PVC	6676217	6182 30 5		119	WDK HT15030GR	akmens pelēks 73/ PVC	6580576	6158 46 3		92		
WDK HI80170RW	dzidri balts 150/ PVC	5042457	6192 10 6		119	WDK HT15030RW	dzidri balts 73/ PVC	6796212	6192 45 9		92		
WDK HI80210CW	krēmbalta 150/ PVC	6106691	6160 49 2		117	WDK HT15040CW	krēmbalta 83/ PVC	6580811	6161 93 6		94		
WDK HI80210GR	akmens pelēks 150/ PVC	6027552	6024 47 5		117	WDK HT15040GR	akmens pelēks 83/ PVC	6580750	6158 47 1		94		
WDK HI80210LGR	gaiši pelēks 150/ PVC	6676279	6182 31 3		117	WDK HT15040RW	dzidri balts 83/ PVC	6494774	6192 46 7		94		
WDK HI80210RW	dzidri balts 150/ PVC	5042525	6192 11 0		117	WDK HT20020CW	krēmbalta 57/ PVC	6580453	6161 90 1		95		
WDK HK100130CW	krēmbalta 282/ PVC	6109456	6162 45 2		118	WDK HT20020GR	akmens pelēks 57/ PVC	6580392	6158 45 5		95		
WDK HK100130GR	akmens pelēks 282/ PVC	6028153	6024 81 5		118	WDK HT20020LGR	gaiši pelēks 57/ PVC	6672851	6182 80 1		95		
WDK HK100130LGR	gaiši pelēks 282/ PVC	6677658	6183 16 6		118	WDK HT20020RW	dzidri balts 57/ PVC	6796274	6192 47 5		95		
WDK HK100130RW	dzidri balts 282/ PVC	5042631	6192 72 6		118	WDK HT20050CW	krēmbalta 93/ PVC	6507795	6152 38 4		97		
WDK HK100230CW	krēmbalta 282/ PVC	6501618	6162 47 9		120	WDK HT20050RW	dzidri balts 93/ PVC	6493272	6154 16 6		97		
WDK HK100230GR	akmens pelēks 282/ PVC	6501670	6024 71 8		120	WDK HT25025CW	krēmbalta 68/ PVC	6580996	6161 94 4		99		
WDK HK100230LGR	gaiši pelēks 282/ PVC	6501373	6183 18 2		120	WDK HT25025GR	akmens pelēks 68/ PVC	6580934	6158 49 8		99		
WDK HK100230RW	dzidri balts 282/ PVC	5042709	6192 73 0		120	WDK HT25025LGR	gaiši pelēks 68/ PVC	6672912	6182 85 2		99		
WDK HK40060CW	krēmbalta 190/ PVC	6108619	6162 00 2		105	WDK HT25025RW	dzidri balts 68/ PVC	6504978	6192 48 3		99		
WDK HK40060GR	akmens pelēks 190/ PVC	6025459	6023 31 2		105	WDK HT25040CW	krēmbalta 83/ PVC	6581177	6161 95 2		101		
WDK HK40060LGR	gaiši pelēks 190/ PVC	6673155	6182 92 5		105	WDK HT25040GR	akmens pelēks 83/ PVC	6581115	6158 50 1		101		
WDK HK40060RW	dzidri balts 190/ PVC	6796519	6192 55 6		105	WDK HT25040RW	dzidri balts 83/ PVC	6796335	6192 49 1		101		
WDK HK40090CW	krēmbalta 230/ PVC	6108671	6162 01 0		106	WDK HT30030CW	krēmbalta 50/ PVC	6581535	6161 97 9		102		
WDK HK40090GR	akmens pelēks 230/ PVC	6024551	6023 14 2		106	WDK HT30030GR	akmens pelēks 50/ PVC	6581474	6158 53 6		102		
WDK HK40090LGR	gaiši pelēks 230/ PVC	6673216	6182 93 3		106	WDK HT30030LGR	gaiši pelēks 50/ PVC	6672974	6182 88 7		102		
WDK HK40090RW	dzidri balts 230/ PVC	6796571	6192 56 4		106	WDK HT30030RW	dzidri balts 50/ PVC	6796397	6192 51 3		102		
WDK HK40110CW	krēmbalta 272/ PVC	6108732	6162 02 9		107	WDK HT30045CW	krēmbalta 88/ PVC	6641956	6161 98 7		103		
WDK HK40110GR	akmens pelēks 272/ PVC	6025572	6023 33 9		107	WDK HT30045GR	akmens pelēks 88/ PVC	6641895	6158 55 2		103		
WDK HK40110LGR	gaiši pelēks 272/ PVC	6673278	6182 94 1		107	WDK HT30045LGR	gaiši pelēks 88/ PVC	6673032	6182 89 5		103		
WDK HK40110RW	dzidri balts 272/ PVC	6500833	6192 57 2		107	WDK HT30045RW	dzidri balts 88/ PVC	6497232	6192 52 1		103		
WDK HK60060CW	krēmbalta 190/ PVC	6108978	6162 20 7		108	WDK HT40040CW	krēmbalta 83/ PVC	6581719	6161 99 5		104		
WDK HK60060GR	akmens pelēks 190/ PVC	6025039	6023 22 3		108	WDK HT40040GR	akmens pelēks 83/ PVC	6581658	6158 54 4		104		
WDK HK60060LGR	gaiši pelēks 190/ PVC	60677054	6183 01 8		108	WDK HT40040LGR	gaiši pelēks 83/ PVC	6673094	6182 91 7		104		
WDK HK60060RW	dzidri balts 190/ PVC	6351794	6192 61 0		108	WDK HT40040RW	dzidri balts 83/ PVC	6796458	6192 54 8		104		
WDK HK60090CW	krēmbalta 230/ PVC	6109036	6162 21 5		109								
WDK HK60090GR	akmens pelēks 230/ PVC	6023837	6023 00 2		109								
WDK HK60090LGR	gaiši pelēks 230/ PVC	6677115	6183 02 6		109	WDK100130CW	krēmbalta 2000/ PVC	6030132	6026 27 3		€m	118	
WDK HK60090RW	dzidri balts 230/ PVC	6492435	6192 62 9		109	WDK100130GR	akmens pelēks 2000/ PVC	6030194	6026 28 1		118		
WDK HK60110CW	krēmbalta 272/ PVC	6109098	6162 22 3		111	WDK100130LGR	gaiši pelēks 2000/ PVC	6668595	6027 24 5		118		
WDK HK60110GR	akmens pelēks 272/ PVC	6023950	6023 02 9		111	WDK100130RW	dzidri balts 2000/ PVC	5042297	6191 34 7		118		
WDK HK60110LGR	gaiši pelēks 272/ PVC	6677177	6183 03 4		111	WDK10020CW	krēmbalta 2000/ PVC	6098170	6150 75 6		86		
WDK HK60110RW	dzidri balts 272/ PVC	6712519	6192 63 7		111	WDK10020RW	dzidri balts 2000/ PVC	6492251	6150 76 4		86		
WDK HK60130CW	krēmbalta 272/ PVC	6109159	6162 23 1		112	WDK100230CW	krēmbalta 2000/ PVC	6642137	6026 31 8		120		
WDK HK60130GR	akmens pelēks 272/ PVC	6024070	6023 04 5		112	WDK100230GR	akmens pelēks 2000/ PVC	6642076	6026 31 1		120		
WDK HK60130LGR	gaiši pelēks 272/ PVC	6677238	6183 04 2	112	WDK100230LGR	gaiši pelēks 2000/ PVC	6668656	6027 25 3	120				
WDK HK60130RW	dzidri balts 272/ PVC	6712571	6192 64 5	112	WDK100230RW	dzidri balts 2000/ PVC	5042303	6191 35 5	120				
WDK HK60150CW	krēmbalta 291/ PVC	6638710	6162 27 4	112	WDK10030CW	krēmbalta 2000/ PVC	6508037	6150 77 2	88				
WDK HK60150GR	akmens pelēks 291/ PVC	6638659	6024 76 9	113	WDK10030RW	dzidri balts 2000/ PVC	6491773	6150 78 0	88				
WDK HK60150LGR	gaiši pelēks 291/ PVC	6677290	6183 05 0	113	WDK15015CW	krēmbalta 2000/ PVC	6642311	6024 96 3	90				
WDK HK60150RW	dzidri balts 291/ PVC	6492497	6192 65 3	113	WDK15015GR	akmens pelēks 2000/ PVC	6642250	6024 95 5	90				
WDK HK60170CW	krēmbalta 291/ PVC	6109210	6162 25 8	114	WDK15015LGR	gaiši pelēks 2000/ PVC	6667338	6024 94 7	90				
WDK HK60170GR	akmens pelēks 291/ PVC	6024193	6023 06 1	114	WDK15015RW	dzidri balts 2000/ PVC	6794058	6191 00 2	90				
WDK HK60170LGR	gaiši pelēks 291/ PVC	6677351	6183 06 9	114	WDK15030CW	krēmbalta 2000/ PVC	6332830	6025 01 3	91				
WDK HK60170RW	dzidri balts 291/ PVC	6712632	6192 66 1	114	WDK15030GR	akmens pelēks 2000/ PVC	6332779	6025 00 5	91				
WDK HK60210CW	krēmbalta 291/ PVC	6109272	6162 26 6	115	WDK15030RW	dzidri balts 2000/ PVC	6794119	6191 01 0	91				
WDK HK60210GR	akmens pelēks 291/ PVC	6024438	6023 12 6	115	WDK15040CW	krēmbalta 2000/ PVC	6028634	6025 16 7	93				
WDK HK60210LGR	gaiši pelēks 291/ PVC	6677412	6183 07 7	115	WDK15040GR	akmens pelēks 2000/ PVC	6028511	6025 13 1	93				
WDK HK60210RW	dzidri balts 291/ PVC	6796632	6192 68 8	115	WDK15040RW	dzidri balts 2000/ PVC	6494590	6191 02 9	93				
WDK HK60230CW	krēmbalta 291/ PVC	6640096	6162 29 0	110									
WDK HK60230GR	akmens pelēks 291/ PVC	6640034	6024 77 7	110	WDK20020CW	krēmbalta 2000/ PVC	6028573	6025 15 3	95				
WDK HK60230LGR	gaiši pelēks 291/ PVC	6677474	6183 08 5	110	WDK20020GR	akmens pelēks 2000/ PVC	6028399	6025 11 0	95				
WDK HK60230RW	dzidri balts 291/ PVC	6492558	6192 69 6	110	WDK20020LGR	gaiši pelēks 2000/ PVC	6667390	6025 10 2	95				
WDK HK80170CW	krēmbalta 282/ PVC	6109333	6162 40 1	119	WDK20020RW	dzidri balts 2000/ PVC	6794171	6191 03 7	95				
WDK HK80170GR	akmens pelēks 282/ PVC	6028030	6024 79 3	119	WDK20035CW	krēmbalta 2000/ PVC	6642854	6026 37 0	96				
WDK HK80170LGR	gaiši pelēks 282/ PVC	6677535	6183 12 3	119	WDK20035GR	akmens pelēks 2000/ PVC	6642793	6026 36 2	96				
WDK HK80170RW	dzidri balts 282/ PVC	5042471	6192 71 8	119	WDK20035LGR	gaiši pelēks 2000/ PVC	6667451	6026 35 4	96				
WDK HK80210CW	krēmbalta 282/ PVC	6109395	6162 42 8	117	WDK20035RW	dzidri balts 2000/ PVC	6496938	6191 04 5	96				
WDK HK80210GR	akmens pelēks 282/ PVC	6028092	6024 80 7	117	WDK20050CW	krēmbalta 2000/ PVC	6438433	6168 70 5	97				
WDK HK80210LGR	gaiši pelēks 282/ PVC	6677597	6183 13 1	117	WDK20050RW	dzidri balts 2000/ PVC	6801671	6168 73 6	97				
WDK HK80210RW	dzidri balts 282/ PVC	5042549	6192 72 2	117	WDK25025CW	krēmbalta 2000/ PVC	6030316	6026 42 7	99				
WDK HS10020CW	krēmbalta 22/ PVC	6098293	6152 00 7	86	WDK25025GR	akmens pelēks 2000/ PVC	6030255	6026 41 9	99				
WDK HS10020RW	dzidri balts 22/ PVC	6492138	6154 02 6	86	WDK25025LGR	gaiši pelēks 2000/ PVC	6667512	6026 40 0	99				
WDK HS10030CW	krēmbalta 32/ PVC	6098354	6152 01 5	88	WDK25025RW	dzidri balts 2000/ PVC	6505036	6191 05 3	99				
WDK HS10030RW	dzidri balts 32/ PVC	6491650	6154 03 4	88	WDK25040CW	krēmbalta 2000/ PVC	6030491	6026 45 1	100				
WDK HS15030CW	krēmbalta 32/ PVC	6507610	6152 03 1	91	WDK25040GR	akmens pelēks 2000/ PVC	6030439	6026 44 3	100				
WDK HS15030GR	akmens pelēks 32/ PVC	6507559	6158 83 8	91	WDK25040RW	dzidri balts 2000/ PVC	6794232	6191 06 1	100				
WDK HS15030RW	dzidri balts 32/ PVC	6223695	6193 50 8	91									
WDK HS15040CW	krēmbalta 42/ PVC	6098477	6152 05 8	93	WDK30030CW	krēmbalta 2000/ PVC	6333011	6026 82 6	102				
WDK HS15040GR	akmens pelēks 42/ PVC	6507498	6158 84 6	93	WDK30030GR	akmens pelēks 2000/ PVC	6332953	6026 81 8	102				
WDK HS15040RW	dzidri balts 42/ PVC	6975266	6193 52 8	93	WDK30030LGR	gaiši pelēks 2000/ PVC	6667574	6026 79 6	102				
WDK HS20050CW	krēmbalta 53/ PVC	6507252	6152 10 4	97	WDK30030RW	dzidri balts 2000/ PVC	6794294	6191 09 6	102				
WDK HS20050RW	dzidri balts 53/ PVC	6974481	6154 06 9	97	WDK30045CW	krēmbalta 2000/ PVC	6640935	6026 86 9	103				
WDK HS25040CW	krēmbalta 42/ PVC	6507375	6152 08 2	100	WDK30045GR	akmens pelēks 2000/ PVC	6640874	6026 85 0	103				
WDK HS25040GR	akmens pelēks 42/ PVC	6507436	6158 88 9	100	WDK30045LGR	gaiši pelēks 2000/ PVC	6667635	6026 84 2	103				
WDK HS25040RW	dzidri balts 42/ PVC	6507313	6193 56 0	100	WDK30045RW	dzidri balts 2000/ PVC	6497058	6191 11 8	103				
WDK HT10020CW	krēmbalta 45/ PVC	6098712	6152 30 9	86									
WDK HT10020RW	dzidri balts 45/ PVC	6491957	6154 11 5	86	WDK40040CW	krēmbalta 2000/ PVC	6028870	6025 41 2</					

# Tipu saraksts

EAN numura uzbūve: valsts kods 40

ražotāja kods 1219 (art. numuriem, kas sākas ar 0: 1010)

individuālais EAN-C 5647589

Tips	Izmērs/krāsa/cits	EAN-C.	Art.-Nr.	Cena	Lapa	Tips	Izmērs/krāsa/cits	EAN-C.	Art.-Nr.	Cena	Lapa	
WDK40040GR	akmens pelēks 2000 / PVC	6028993	6025 44 7	€/m	104	WDK-HI40060	dzidri balts 85 / PC/ABS	5237495	6175 05 7	€/gab.	130	
WDK40040LGR	gaiši pelēks 2000 / PVC	6667697	6027 01 6		104	WDK-HI40061	dzidri balts 85 / PC/ABS	5237501	6175 06 3		131	
WDK40040RW	dzidri balts 2000 / PVC	6363490	6191 12 6		104	WDK-HI60090	dzidri balts 130 / PC/ABS	5237518	6175 06 9		132	
WDK40060CW	krēmbalta 2000 / PVC	6016273	6020 88 7		105	WDK-HI60110	dzidri balts 130 / PC/ABS	5237525	6175 07 5		133	
WDK40060GR	akmens pelēks 2000 / PVC	6029112	6025 63 3		105	WDK-HI60150	dzidri balts 130 / PC/ABS	5237532	6175 08 1		134	
WDK40060LGR	gaiši pelēks 2000 / PVC	6667758	6027 02 4		105	WDK-HT30045	dzidri balts 130 / PC/ABS	5237785	6175 25 5		129	
WDK40060RW	dzidri balts 2000 / PVC	6794355	6191 13 4		105	WDK-HT40060	dzidri balts 170 / PC/ABS	5237815	6175 26 1		130	
WDK40090CW	krēmbalta 2000 / PVC	6016334	6020 89 5		106	WDK-HT40061	dzidri balts 170 / PC/ABS	5237822	6175 26 7		131	
WDK40090GR	akmens pelēks 2000 / PVC	6016877	6021 01 8		106	WDK-HT60090	dzidri balts 170 / PC/ABS	5237839	6175 27 3		132	
WDK40090LGR	gaiši pelēks 2000 / PVC	6667819	6027 03 2		106	WDK-HT60110	dzidri balts 190 / PC/ABS	5237846	6175 27 9		133	
WDK40090RW	dzidri balts 2000 / PVC	6794416	6191 14 2	106	WDK-HT60150	dzidri balts 250 / PC/ABS	5237877	6175 28 5	134			
WDK40110CW	krēmbalta 2000 / PVC	6016396	6020 90 9	107								
WDK40110GR	akmens pelēks 2000 / PVC	6016990	6021 03 4	107						€/m		
WDK40110LGR	gaiši pelēks 2000 / PVC	6667871	6027 04 0	107	WDKM11	dzidri balts 2000 / PVC	6798193	6150 10 1	84			
WDK40110RW	dzidri balts 2000 / PVC	6501199	6191 15 0	107	WDKM7	dzidri balts 2000 / PVC	6798070	6150 07 1	84			
					WDKM9	dzidri balts 2000 / PVC	6798131	6150 09 8	84			
WDK60060CW	krēmbalta 2000 / PVC	6020171	6021 94 8	108	WDKMD12CW	krēmbalta 2000 / PVC	6097692	6150 17 9	84			
WDK60060GR	akmens pelēks 2000 / PVC	6029174	6025 66 8	108	WDKMD12RW	dzidri balts 2000 / PVC	6493036	6150 28 4	84			
WDK60060LGR	gaiši pelēks 2000 / PVC	6667994	6027 10 5	108	WDKMD17CW	krēmbalta 2000 / PVC	6097753	6150 18 7	85			
WDK60060RW	dzidri balts 2000 / PVC	6363018	6191 19 3	108	WDKMD17RW	dzidri balts 2000 / PVC	6492978	6150 29 2	85			
WDK60090CW	krēmbalta 2000 / PVC	6020119	6021 91 3	109	WDKMD4CW	krēmbalta 2000 / PVC	6097579	6150 15 2	84			
WDK60090GR	akmens pelēks 2000 / PVC	6020232	6022 00 6	109	WDKMD4RW	dzidri balts 2000 / PVC	6493159	6150 26 8	84			
WDK60090LGR	gaiši pelēks 2000 / PVC	6668052	6027 11 3	109	WDKMD7CW	krēmbalta 2000 / PVC	6097630	6150 16 0	84			
WDK60090RW	dzidri balts 2000 / PVC	6491292	6191 20 7	109	WDKMD7RW	dzidri balts 2000 / PVC	6493098	6150 27 6	84			
WDK60110CW	krēmbalta 2000 / PVC	6019816	6021 84 0	111								
WDK60110GR	akmens pelēks 2000 / PVC	6020294	6022 01 4	111	WDK-N10020CW	krēmbalta 2000 / PVC	6097814	6150 40 3	86			
WDK60110LGR	gaiši pelēks 2000 / PVC	6668113	6027 12 1	111	WDK-N10020RW	dzidri balts 2000 / PVC	6492190	6150 41 1	86			
WDK60110RW	dzidri balts 2000 / PVC	6363438	6191 21 5	111	WDK-N10030CW	krēmbalta 2000 / PVC	6097876	6150 44 6	88			
WDK60130CW	krēmbalta 2000 / PVC	6019878	6021 85 9	112	WDK-N10030RW	dzidri balts 2000 / PVC	6491711	6150 45 4	88			
WDK60130GR	akmens pelēks 2000 / PVC	6020355	6022 02 2	112	WDK-N15030CW	krēmbalta 2000 / PVC	6507979	6150 51 9	91			
WDK60130LGR	gaiši pelēks 2000 / PVC	6668175	6027 14 8	112	WDK-N15030RW	dzidri balts 2000 / PVC	6493456	6150 52 7	91			
WDK60130RW	dzidri balts 2000 / PVC	6363377	6191 22 3	112	WDK-N15040CW	krēmbalta 2000 / PVC	6097999	6150 53 5	93			
WDK60150CW	krēmbalta 2000 / PVC	6637577	6021 88 3	113	WDK-N15040RW	dzidri balts 2000 / PVC	6494477	6150 54 3	93			
WDK60150GR	akmens pelēks 2000 / PVC	6637515	6022 03 0	113	WDK-N20050CW	krēmbalta 2000 / PVC	6438495	6168 72 8	97			
WDK60150LGR	gaiši pelēks 2000 / PVC	6668236	6027 15 6	113	WDK-N20050RW	dzidri balts 2000 / PVC	6802159	6168 74 4	97			
WDK60150RW	dzidri balts 2000 / PVC	6491230	6191 23 1	113	WDK-N25040CW	krēmbalta 2000 / PVC	6507191	6150 63 2	100			
WDK60170CW	krēmbalta 2000 / PVC	6019939	6021 86 7	114	WDK-N25040RW	dzidri balts 2000 / PVC	6975686	6150 64 0	100			
WDK60170GR	akmens pelēks 2000 / PVC	6020416	6022 04 9	114								
WDK60170LGR	gaiši pelēks 2000 / PVC	6668298	6027 16 4	114						€/gab.		
WDK60170RW	dzidri balts 2000 / PVC	6363193	6191 25 8	114	WS-B AL0.5	aluminija lakots	5275756	6117 62 8	347			
WDK60210CW	krēmbalta 2000 / PVC	6019991	6021 87 5	115	WS-B AL1	aluminija lakots	5275862	6117 64 1	347			
WDK60210GR	akmens pelēks 2000 / PVC	6020478	6022 06 5	115	WS-B RW0.5	dzidri balts	5275749	6117 62 7	347			
WDK60210LGR	gaiši pelēks 2000 / PVC	6668359	6027 17 2	115	WS-B RW1	dzidri balts	5275824	6117 64 0	347			
WDK60210RW	dzidri balts 2000 / PVC	6794478	6191 26 6	115	WS-B SWGR0.5	pelēkmelna	5701033	6117 62 6	347			
WDK60230CW	krēmbalta 2000 / PVC	6638956	6021 89 1	110	WS-B SWGR1	pelēkmelna	5701071	6117 64 2	347			
WDK60230GR	akmens pelēks 2000 / PVC	6638895	6022 05 7	110								
WDK60230LGR	gaiši pelēks 2000 / PVC	6668410	6027 18 0	110	ZL-SKS	krēmbalta / PVC	6180196	6117 20 5	344			
WDK60230RW	dzidri balts 2000 / PVC	6799459	6191 27 4	110	ZL-SKS	krēmbalta / PVC	6180196	6117 20 5	346			
WDK80170CW	krēmbalta 2000 / PVC	6029778	6026 17 6	119								
WDK80170GR	akmens pelēks 2000 / PVC	6029839	6026 18 4	119	ZP-80 1AL	aluminija lakots	5406013	6258 07 4	356			
WDK80170LGR	gaiši pelēks 2000 / PVC	6668472	6027 22 9	119	ZP-80 1RW	dzidri balts	5406006	6258 07 3	356			
WDK80170RW	dzidri balts 2000 / PVC	5042273	6191 30 4	119								
WDK80210CW	krēmbalta 2000 / PVC	6029952	6026 20 6	117								
WDK80210GR	akmens pelēks 2000 / PVC	6029891	6026 19 2	117								
WDK80210LGR	gaiši pelēks 2000 / PVC	6668533	6027 23 7	117								
WDK80210RW	dzidri balts 2000 / PVC	5042280	6191 31 2	117								
WDK-H20020	dzidri balts 2000 / PC/ABS	5237396	6175 00 2	128								
WDK-H30045	dzidri balts 2000 / PC/ABS	5237402	6175 00 8	129								
WDK-H40060	dzidri balts 2000 / PC/ABS	5237419	6175 01 4	130								
WDK-H40061	dzidri balts 2000 / PC/ABS	5237426	6175 02 0	131								
WDK-H60090	dzidri balts 2000 / PC/ABS	5237457	6175 02 6	132								
WDK-H60110	dzidri balts 2000 / PC/ABS	5237464	6175 03 2	133								
WDK-H60150	dzidri balts 2000 / PC/ABS	5237471	6175 03 8	134								
WDK-HA30045	dzidri balts 60 / PC/ABS	5237549	6175 10 3	129						€/gab.		
WDK-HA40060	dzidri balts 85 / PC/ABS	5237556	6175 10 9	130								
WDK-HA40061	dzidri balts 85 / PC/ABS	5237563	6175 11 5	131								
WDK-HA60090	dzidri balts 130 / PC/ABS	5237570	6175 12 1	132								
WDK-HA60110	dzidri balts 130 / PC/ABS	5237587	6175 12 7	133								
WDK-HA60150	dzidri balts 130 / PC/ABS	5237594	6175 13 3	134								
WDK-HE20020	dzidri balts 19 / PC/ABS	5237600	6175 15 0	128								
WDK-HE30045	dzidri balts 45 / PC/ABS	5237631	6175 15 6	129								
WDK-HE40060	dzidri balts 60 / PC/ABS	5237648	6175 16 2	130								
WDK-HE40061	dzidri balts 60 / PC/ABS	5237655	6175 16 8	131								
WDK-HE60090	dzidri balts 90 / PC/ABS	5237662	6175 17 4	132								
WDK-HE60110	dzidri balts 110 / PC/ABS	5237693	6175 18 0	133								
WDK-HE60150	dzidri balts 150 / PC/ABS	5237709	6175 18 6	134								
WDK-HF30045	dzidri balts 60 / PC/ABS	5237716	6175 20 4	129								
WDK-HF40060	dzidri balts 85 / PC/ABS	5237723	6175 21 0	130								
WDK-HF40061	dzidri balts 85 / PC/ABS	5237730	6175 21 6	131								
WDK-HF60090	dzidri balts 120 / PC/ABS	5237747	6175 22 2	132								
WDK-HF60110	dzidri balts 140 / PC/ABS	5237754	6175 22 8	133								
WDK-HF60150	dzidri balts 180 / PC/ABS	5237778	6175 23 4	134								
WDK-HI30045	dzidri balts 60 / PC/ABS	5237488	6175 05 1	129								

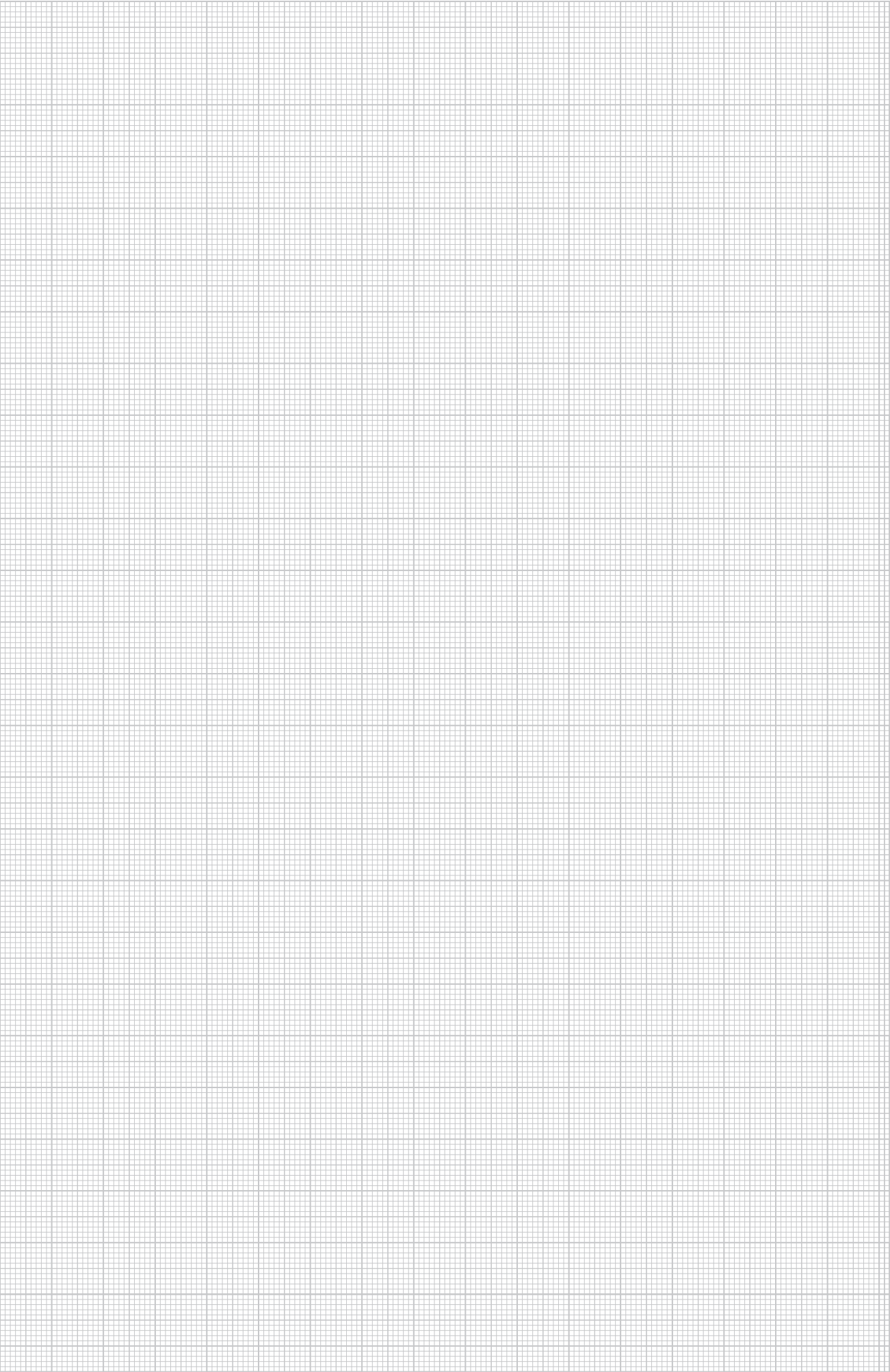



**OBO Bettermann OÜ**

Pärnu mnt. 160G  
11317 Tallinn

**Klienditeenindus Eestis**

Tel. +372 6519 870  
Faks +372 6519 878  
E-post: info@obo.ee

**[www.obo.ee](http://www.obo.ee)**