

TBS

External lightning protection

Lightning protection components
for lightning protection systems
conforming to DIN/VDE

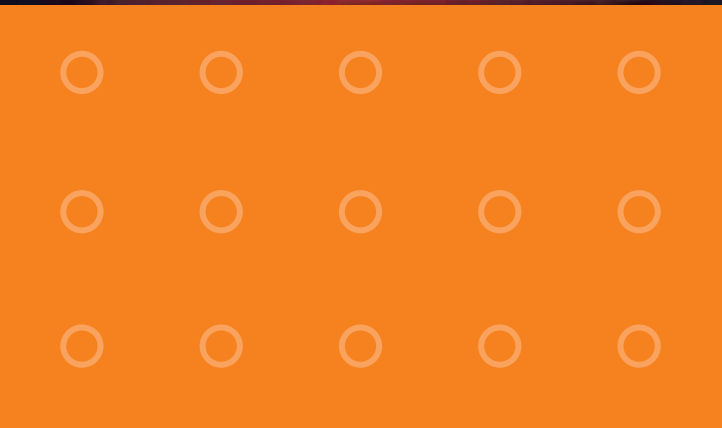

OBO lightning protection systems

The complete range of lightning protection systems conforming to DIN/VDE



With OBO, the construction of lightning protection systems in accordance with guidelines VDE 0185 becomes a matter of routine. With safety.

These selected OBO components make it easier and more economical than ever before to construct lightning protection systems conforming to DIN/VDE.

On the basis of years of experience, a "lightning protection kit" consisting of proven components which are

easy to install has been assembled for single and multi-family houses. The high quality means you can be sure of two things: satisfied customers and protection from lightning.

Another significant advantage is the slimming-down of the product range – a result of applying the modular principle, which makes the range easy to stock and understand. You will quickly see for yourself – as soon as you have studied this brochure in more detail – how few parts are

needed to install lightning protection in line with DIN/VDE 0185, and how much simpler and more attractive this future-proof and profitable area of business consequently becomes for electrical installation firms.

Many lightning protection components are also available in copper or brass. Ask your electrical wholesaler.

The lightning collector

is the part of the external lightning protection system that is designed to collect the lightning.



The conductor system

is the part of the external lightning protection system that is designed to conduct the lightning current from the collector to the earthing installation.



The earthing installation

is the part of the external lightning protection system that carries the lightning current into the earth.



The lightning protection potential equalisation

is the part of the internal lightning protection system that reduces potential differences caused by the lightning current.



OBO lightning protection guide

Principles of external lightning protection



Lightning is one of the natural phenomena that has always fascinated mankind. Although much marvelled at, lightning presents considerable danger to people and their surroundings. Differences in electrical charge between the inside of clouds and the earth, which occur predominantly in the summer months, lead to storm fronts.

The lightning that we see consists mostly of an impressed negative current flowing from the clouds to the earth. If a building is struck by lightning, the lightning current heats up the point where the lightning struck and the masonry itself. This could cause fire to break out.

In Germany, several hundred million euro's worth of damage is caused by lightning strikes every year. Lightning protection systems professionally installed in accordance with the regulations offer effective protection from direct lightning strikes.

DIN/VDE standard 0185 Part 1 and Part 2 of November 1982 is still the basic guide to the installation and testing of lightning protection systems. Recommended standards are ENV 61024-1, and for Germany DIN/VDE 0185 Part 100 and DIN/VDE 0185 Part 103, since these publications reflect the current state of technology knowledge.

Depending on the construction and use of the building, and the consequential damage weighed against the accepted frequency of lightning strikes, one of four lightning protection classes is assigned for the building to be protected.

Protection class	Peak lightning current
I	200 kA
II	150 kA
III	100 kA
IV	100 kA

The lightning protection classes (BKZ) define parameters that are necessary for the installation of a lightning protection system. The table above lists the lightning protection classes and their associated peak lightning current values.

A program to calculate lightning protection classes in accordance with IEC 61024-1, DIN V VDE 0185 Part 100 is available on request.

Structure of a lightning protection system

A lightning protection system (LPS) is made up of the following function units:

1. Lightning collector: the part of the external lightning protection system that is designed to collect the lightning.



A. Protective angle method

The protective angle method is a way of designing a lightning collector. The building to be protected must be situated within the space protected by the collector rods or the collector device. The protective angle depends on the height of the building; it can be taken from DIN V VDE standard 0185 Part 100. Taking a protective angle of 45° as an example, buildings up to 30 metres high can be protected (BKZ 3 < 30 metres, BKZ 2 < 15 metres, BKZ 1 < 10 metres).

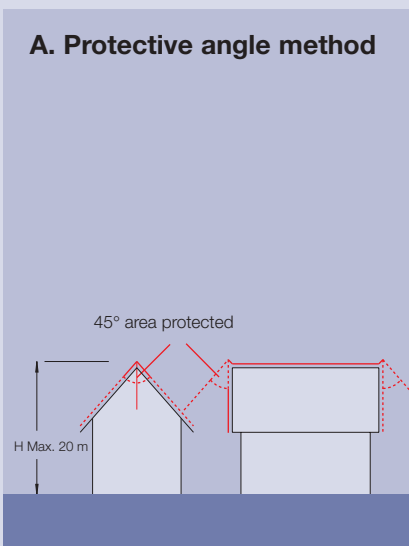

B. Mesh method

Another way of setting up a lightning collector is the mesh method. Starting from the preferred lightning strike points, such as ridges, hips and edges, collector wires are laid on the roof surfaces in the form of a mesh. The table below shows the mesh dimensions for each lightning protection class.

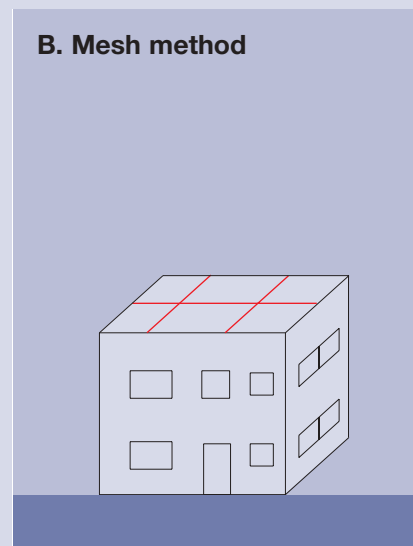

Protection class	Mesh size
I	5*5 m
II	10*10 m
III	15*15 m
IV	20*20 m

C. Lightning sphere method

Collector designs can also be determined with the lightning sphere method. This method requires a model of the object to be protected and a sphere that is rolled over the model. A lightning collector must be installed at all points touched by the sphere. With this method too, the lightning protection class determines the degree of protection to be expected, on the basis of the radius of the sphere. The lightning sphere method is intended for larger and more complex buildings, where the higher cost compared with the protective angle method and the mesh method is justified.

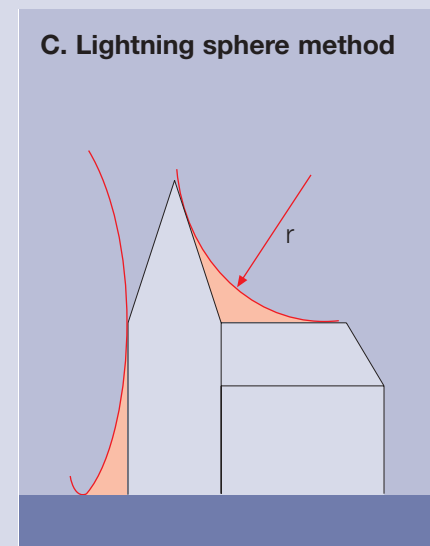

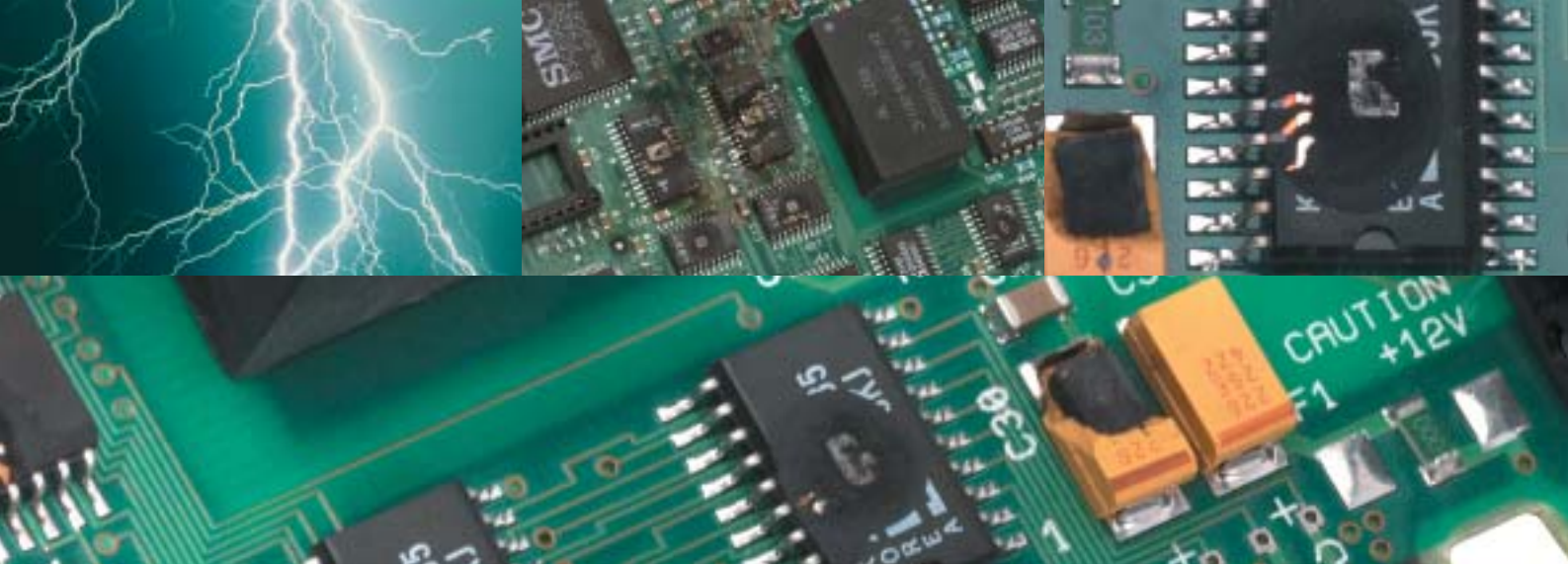

2. Lightning conductor system: the part of the external lightning protection system that is designed to conduct the lightning current from the collector to the earthing installation.

The number of lightning conductors depends on the size of the building to be protected, but at least two conductors must be installed. When installing lightning conductors, it is essential to keep current paths short and to avoid loops. The table below shows the distances between the conductors and the associated lightning protection classes.

Protection class	Mesh size
I	10 m
II	15 m
III	20 m
IV	25 m

3. Earthing installation: the part of the external lightning protection system that carries the lightning current into the earth.

Examples of common earthing systems such as single earthing devices (deep earths, radial earths, plate earths), ring earth (surface earths) or foundation earths are shown on the pages that follow.

4. Lightning protection potential equalisation: the part of the internal lightning protection system that reduces potential differences caused by the lightning current.

For this, power wiring and data wiring (telecommunication wires, control system wiring, cable television, etc.) must be included in the lightning protection potential equalisation. This is done with lightning arresters of requirement class B to DIN VDE 0675 Part 6 (A1/A2). Electric power lines must be connected to the lightning arresters of requirement class B as close as possible to the place where they enter the building (the domestic connection box, for example). Here are two installations by way of example:

If the meter is not located immediately adjacent to the domestic connection box, the lightning arrester must be installed upstream of the meter. Here, the installation must be approved by the local electricity supply company. In this case we recommend lightning arrester type MC 50-B (see page 18). This arrester satisfies all the conditions of the VDEW guidelines and bears VDE, ÖVE and KEMA KEUR approval marks. It is advisable to install surge protection of requirement class C to DIN/VDE 0675 Part 6 (A1/A2) as well as the lightning arresters. Even if the surge arrester is not strictly required by the regulations, it is important to suggest to the customer that surge protection should be provided as well.

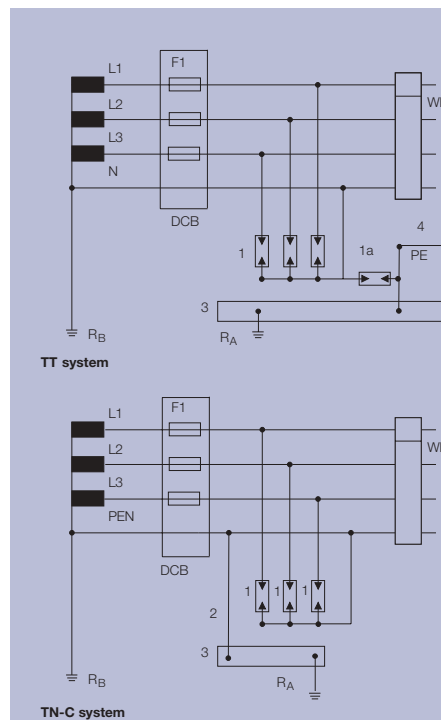

Installation examples

- 1 Lightning arresters
- 1a NPE spark gap
- 2 Equipotential bonding conductor
- 3 Main equipotential bonding bar
- 4 Earth connection
- F1 Main fuses

Combinations of materials

Material	Steel, hot-dip galvanised (FT)	Aluminium (Alu)	Copper (Cu)	Stainless steel (VA)
Steel, hot-dip galvanised	recommended	possible	not recommended	possible
Aluminium (Alu)	possible	recommended	not recommended	possible
Copper (Cu)	not recommended	not recommended	recommended	possible
Stainless steel (VA)	possible	possible	possible	recommended

Materials and hardware

Wherever there is a junction between different materials there is a risk of corrosion. For this reason, copper parts should never be installed together with galvanised surfaces or aluminium components, since rain or other effects may result in copper particles reaching the galvanised or aluminium surfaces. Places where there is a high risk of corrosion, for example where conductors enter concrete or the ground, must also be protected from corrosion. Buried connections must be suitably coated to prevent corrosion. Bare aluminium must not be placed in direct contact with plaster, mortar or concrete and must not be buried. The table above shows some combinations of metals that are possible from the point of view of contact corrosion.

Testing lightning protection systems

After acceptance testing, lightning protection systems must be re-tested at set intervals to ensure that they are still working properly and to allow improvements to be made where possible. The tests should be carried out with reference to DIN VDE standard 0185 Part 110 and its technical principles. A test report covering the following points must be written:

- ▶ General condition of collector cables and other collector system components.
- ▶ General condition of the degree of corrosion.
- ▶ Soundness of the fixings of the cables and the components of the lightning protection system.
- ▶ Any deviations from the requirements of IEC 61024-1.
- ▶ Documentation of all changes and additions to the LPS and changes to the physical installation. In addition, final drawings and the draft description of the LPS must be checked.
- ▶ Test results.

There is a test report form in an appendix to this catalogue.

Tested lightning protection components

Components for the construction of lightning protection systems used to be defined by the series of standards DIN 48801 to DIN 48852, which gave prominence to component dimensions. In August 1999, EN 50164-1 (DIN/VDE 0185 Part 201) came into force. Connection components are tested to this standard. After a conditioning phase totalling ten days, the components are subjected to three current surges. They are assigned to one of two test classes:

Test class H



“Tested with three 100 kA current surges, waveform 10/350 µs.”

Test class N



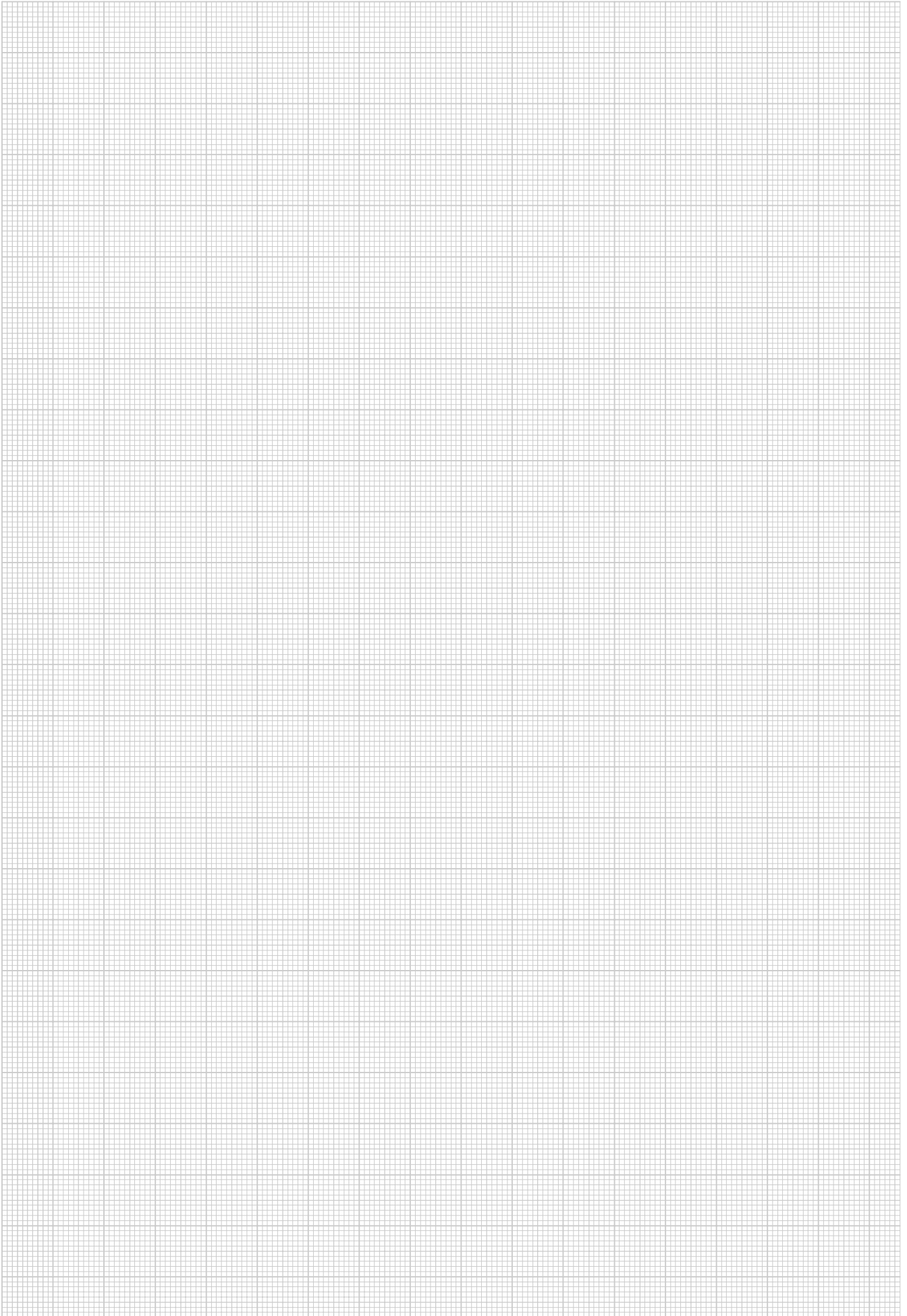

“Tested with three 50 kA current surges, waveform 10/350 µs.” Further information on our lightning protection components tested to EN 50164-1 is available on request.

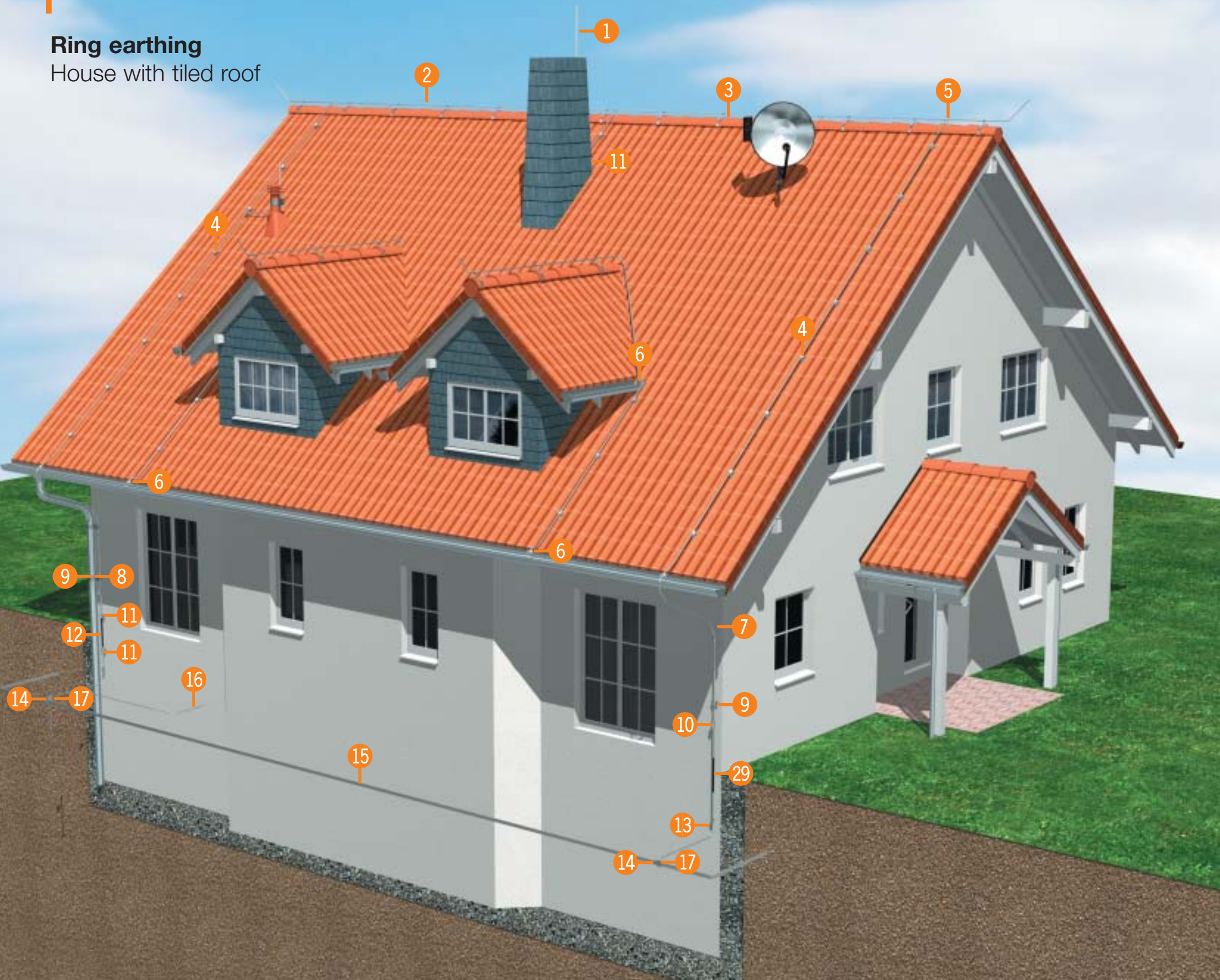

Ring earthing

House with tiled roof



- 

1 Lightning rod
Type 101/G-DIN



18 Cross-connector
Type 252/16-FL
- 

2 Round conductor
Type Rd8/ALU-T



14 Cross-connector
Type 256/A-DIN
- 

3 Roof cable holder
Type 132/K-VA



15 Strap conductor
Type 5052
- 

4 Roof cable holder
Type 157/FK-VA

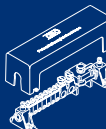

16 Equipotential
bonding bar
Type 1801 VDE
- 

5 Vario quick
connector
Type 249/ST



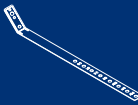

19 Flexible
anti-corrosion
bandages
Type 356
- 

6 Gutter clip
Type 267
- 

7 Cable holder
Type 113/Z 8-10
- 

8 Gutter downpipe
bracket
Type 301/V
- 

9 Terminal block
tab
Type 324/S
- 

10 Test joint
Type 223/DIN
- 

11 Rod holder
Type 113/Z-16
- 

12 Earth entry bar
Type 200

A ring earth is a surface earth which is laid, if possible, in a closed ring around the outside foundation of the building at a distance of one metre and a depth of half a metre. Earth entry bars of galvanised steel must be treated to prevent corrosion over at least 30 cm upward and downward from the surface of the ground. Anti-cor-

rosion bandage type 356 is suitable for this purpose. Non-permanent connections in the ground must also be protected with an anti-corrosion bandage. The cable holders and roof cable holders should not be more than 1.2 m apart. The ring earth must have a conducting connection to the equipotential bonding bar.

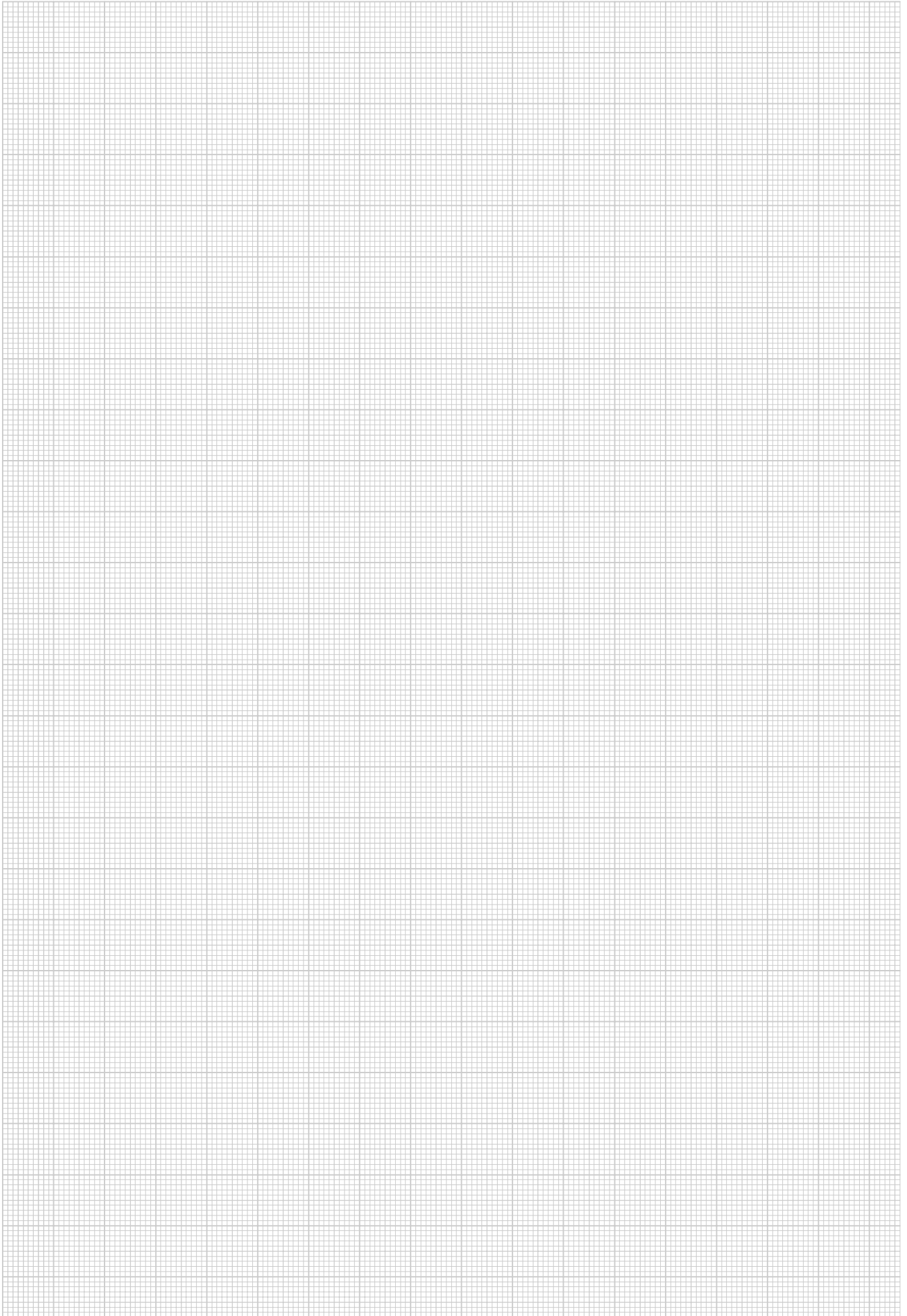

Deep earthing

House with tiled roof

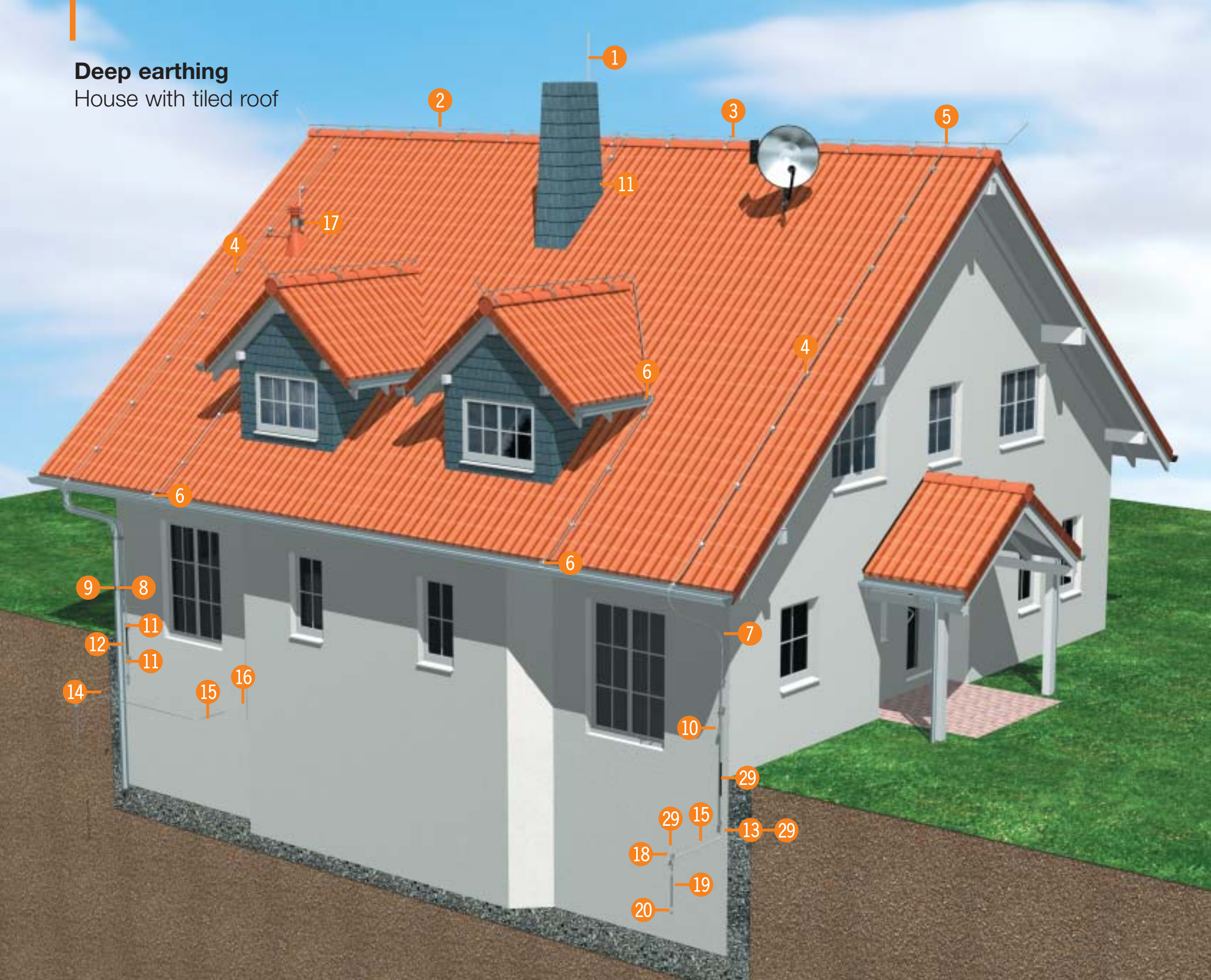

- | | | | |
|---------------------------------------------------------------------------------------|---------------------------------------------------|---------------------------------------------------------------------------------------|---------------------------------------------------------------|
|  | 1 Lightning rod
Type 101/G-DIN |  | 13 Cross-connector
Type 252/16-FL |
|  | 2 Round conductor
Type Rd8/ALU-T |  | 14 Cross-connector
Type 256/A-DIN |
|  | 3 Roof cable holder
Type 132/K-VA |  | 15 Strap conductor
Type 5052 |
|  | 4 Roof cable holder
Type 157/FK-VA |  | 16 Equipotential
bonding bar
Type 1801 VDE |
|  | 5 Vario quick
connector
Type 249/ST |  | 17 Pipe clip
Type 303/DIN |
|  | 6 Gutter clip
Type 267 |  | 18 Connection clamp
Type 2760/20 |
|  | 7 Cable holder
Type 113/Z 8-10 |  | 19 Earthing rod
Type 219/20 BP |
|  | 8 Gutter downpipe
bracket
Type 301/V |  | 20 Driving pin
Type 1819/20 BP |
|  | 9 Terminal block tab
Type 324/S |  | 29 Flexible anti-
corrosion
bandages
Type 356 |
|  | 10 Test joint
Type 223/DIN | | |
|  | 11 Rod holder
Type 113/Z-16 | | |
|  | 12 Earth entry bar
Type 200 | | |

A deep earth rod is an earth rod which is driven down to a great depth, usually vertically. For each lightning conductor, a single deep earth rod nine metres long (according to DIN VDE 0185 Part 1) must be installed about one metre away from the foundation of the building. According to DIN VDE 0185 Part 100, there are additional aspects to consider. The required earth rod

length may be divided into several lengths connected in parallel. Depending on the nature of the ground, earth rods are driven in manually or with a suitable electric, petrol or pneumatic power hammer. Removable connections in the soil must be protected from corrosion (with a flexible corrosion bandage).

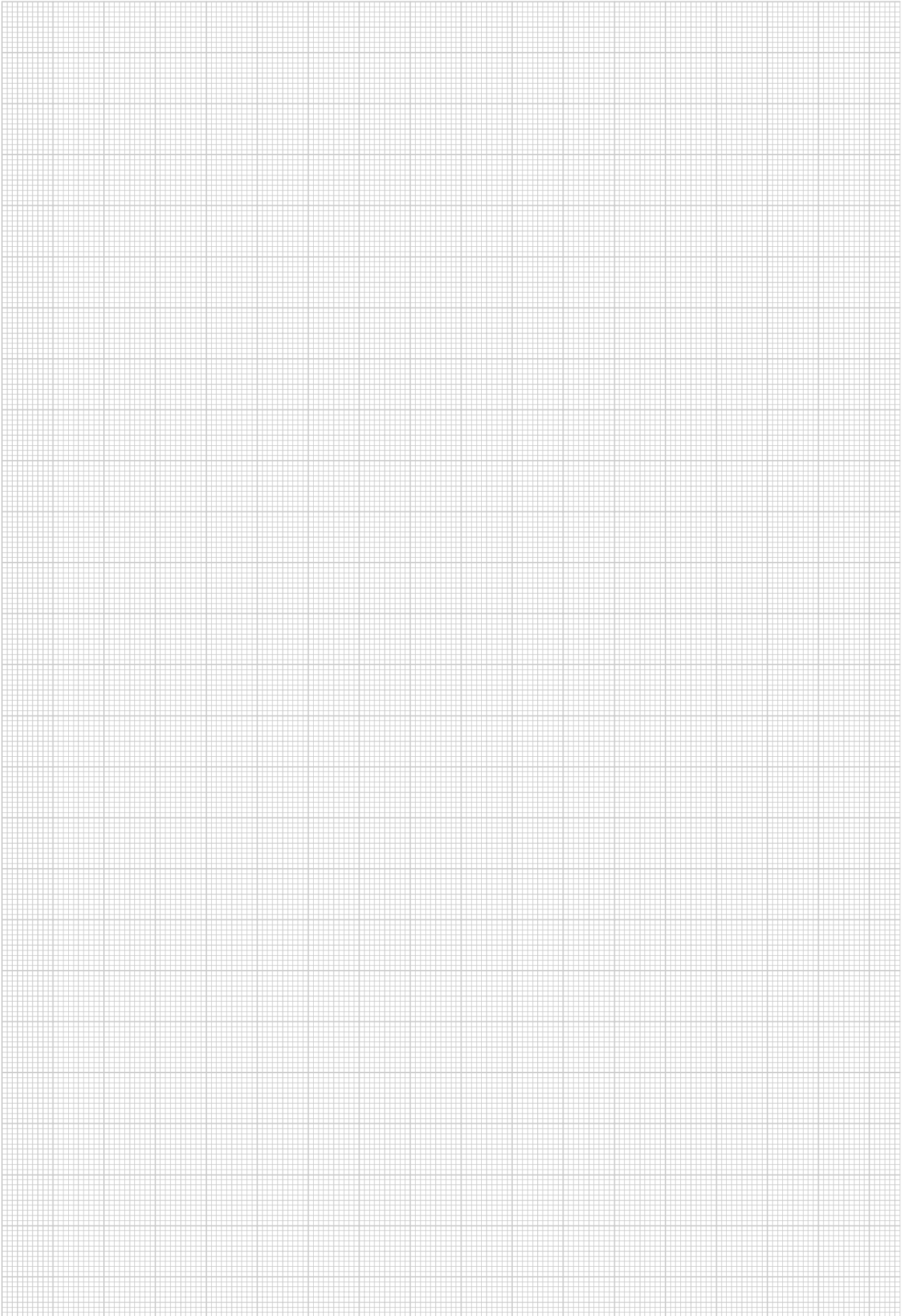

Foundation earthing Flat-roofed building

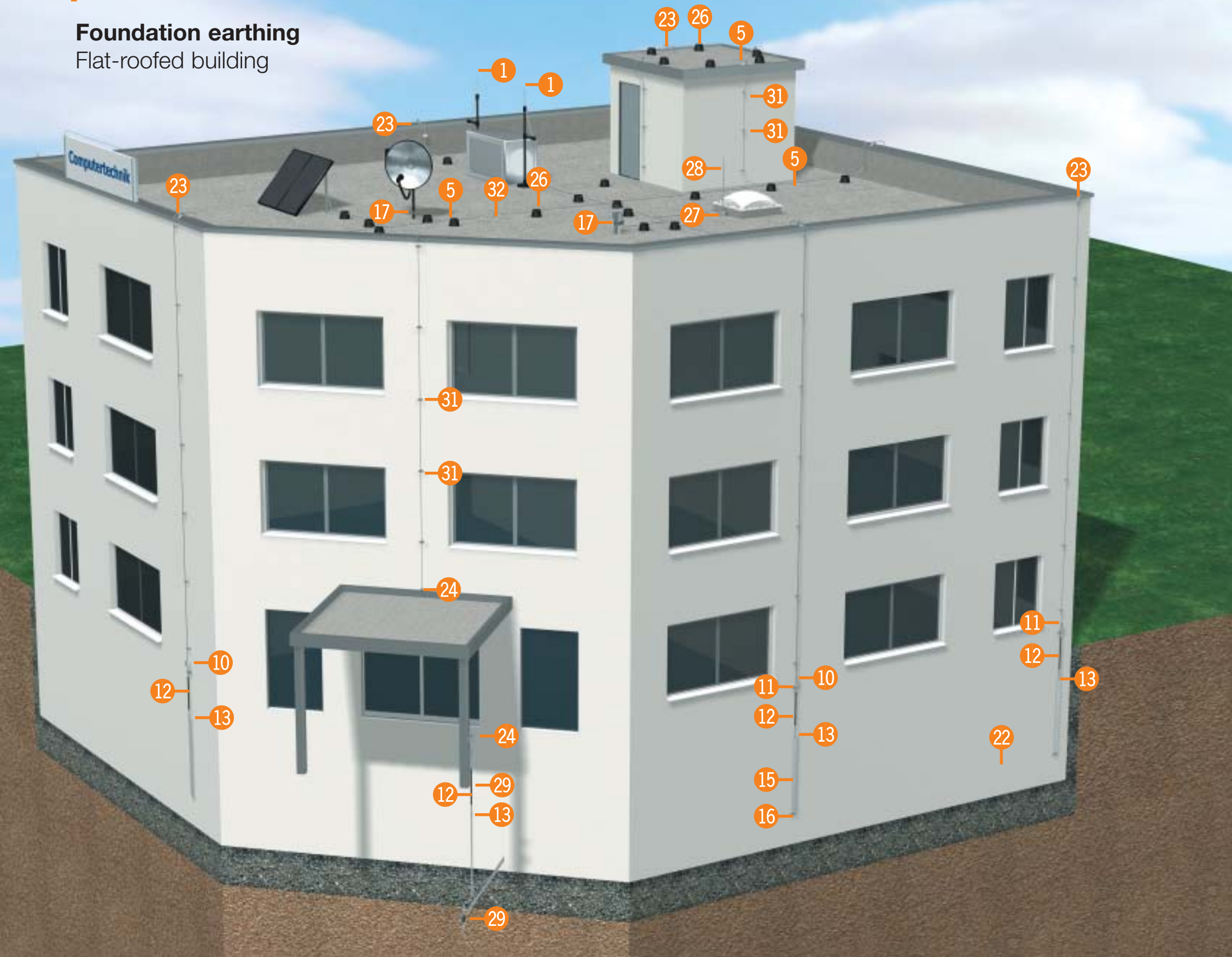

A foundation earth is a conductor embedded in the concrete foundation of a building, which provides an earth for lightning protection, among other things, if the terminal tabs needed to connect the lightning conductors are brought out from the foundation. Branches and connections in the foundation can be made by means of wedge connectors. Wedge connectors must not be used in the ground. When

installing the foundation earth rod, we recommend using strap holders to ensure a clean run. The holders (21) should be positioned about two metres apart. On flat roofs, roof cable holders should not be more than one metre apart. The sheet metal covering is used as a lightning collector. Where the conductor is more than 20 metres long, at least one expansion piece is needed.

1 Information on OBO isolated lightning rods is available on request



23 Connecting and bridging component Type 288/DIN



2 Round conductor Type Rd8/ALU-T



24 Connecting component Type 287/DIN



5 Vario quick connector Type 249/ST



26 Roof cable holder Type 165/MBG



10 Test joint Type 223/DIN

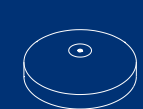

27 Stand Type 101/...



11 Rod holder Type 113/Z-16

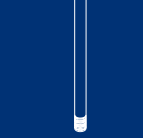

28 Lightning rod Type 101 ALU



12 Earth entry bar Type 200



29 Flexible anti-corrosion bandages Type 356



18 Cross-connector Type 252/16-FL



31 Screwless cable holder Type 177/...-DIN



15 Strap conductor Type 5052



32 Expansion piece Type 172/AR

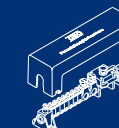

16 Equipotential bonding bar Type 1801/VDE



17 Pipe clip Type 303/DIN



21 Spacer Type 1811



22 Wedge connector Type 1813

Lightning rods

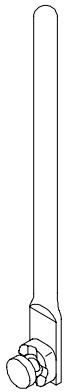

1

101/G-DIN

16 mm Ø

Similar to DIN 48802, Form A3

With forged-on tab, rounded; fitted with connector (one-piece) 5001 DIN for round conductor Rd 8-10

Type	Length mm	Nom. size Ø mm	Pack qty	Weight kg/100	Order no. FT
101/G-DIN	1000	16	10	164.300	5402107
101/G-DIN	1500	16	10	240.000	5402158

DIN 48802, Form A3

Round conductors

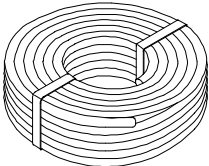

2

RD 8/ALU-T

Material: aluminium, soft, twist quality Rd 8/ALU-T

Type	Ø mm	Material	Weight kg/100 m	Order no.
RD 8/ALU-T**	8	Alu***	13.500	5021294

** Not to DIN 48801

*** Twist quality

Roof cable holders

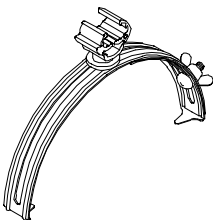

3

132/K-VA

With cable holder 177/20 of grey polyamide, lower part of stainless steel

Type	To fit mm	Material	Pack qty	Weight kg/100	Order no.
132/K-VA	Rd 8-10	VA/PA	50	10.900	5202515
132/K-Cu	Rd 8-10	Cu/PA	50	11.600	5202590

Roof cable holders

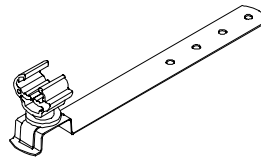

4

157/FK-VA

For tiled roofs, with cable holder 177/20 of grey polyamide, lower part of stainless steel

Type	To fit mm	Length mm	Material	Pack qty	Weight kg/100	Order no.
157/FK-VA	Rd 8-10	230	VA/PA	50	7.800	5215544
157/FK-VA	Rd 8-10	280	VA/PA	50	10.165	5215587
157/FK-VA	Rd 8-10	410	VA/PA	50	14.884	5215609

157/LK-VA

For slate roofs, with cable holder 177/20 of grey polyamide, lower part of stainless steel

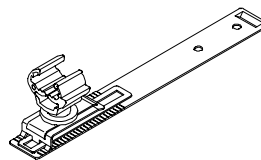

4

Type	To fit mm	Material	Pack qty	Weight kg/100	Order no.
157/LK-VA	Rd 8-10	VA/PA	50	8.000	5215374

Vario quick connectors

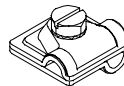

5

249/ST

Suitable for connecting round conductors Rd 8 and Rd 10

The design allows parallel, tee and cross connections to be made

Type	To fit mm	Material	Pack qty	Weight kg/100	Order no.
249/ST	Rd 8-10	FT	50	10.800	5311500
249/Alu	Rd 8-10	Alu	50	6.600	5311519
248/VA	Rd 8-10	VA	50	10.700	5311551

Gutter clips

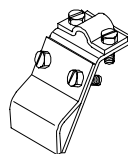

6

262

To connect cables to gutters (of steel = 262/A-DIN / of copper = 262/ZM), suitable for all edge bead thicknesses. Fitted with 2 screws DIN 933/M6 x 12 and 2 screws DIN 933/M8 x 30, stainless steel

Type	To fit mm	Material	Pack qty	Weight kg/100	Order no.
262	Rd 8-10	FT	25	19.610	5316014
262/ZM	Rd 8-10	Cu/FT	25	23.100	5316170

Cable holders

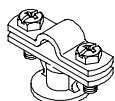

7

113/Z 8-10

Suitable for round conductor Rd 8-10, with crossbar, fitted with 2 M6 x 16 hexagon head screws, with M8 female thread and through hole

Type	To fit mm	Material	Pack qty	Weight kg/100	Order no.
113/Z 8-10	Rd 8-10	Zn	50	6.202	5229960

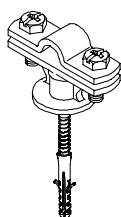

7

113/B-Z-HD 8-10

Suitable for round conductor Rd 8-10, with crossbar, fitted with 2 M6 x 16 hexagon head screws, of stainless steel VA (1.4303), 5 x 60 wood screw and 8 mm plastic plug

Type	To fit mm	Material	Pack qty	Weight kg/100	Order no.
113/B-Z-HD 8-10	Rd 8-10	Zn	100	6.580	5230322

Gutter downpipe brackets

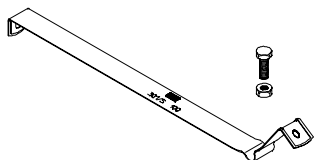

8

301/S

With bead, cable holder for gutter downpipes

Type	For pipe mm	Material	Pack qty	Weight kg/100	Order no.
301/S	100	FS	50	5.200	5351057
301/S	120	FS	50	5.950	5351073

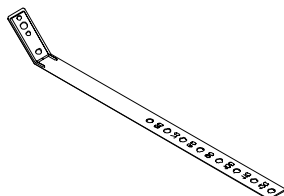

8

301/V

With two Ø 7 mm connecting holes, one Ø 9 mm connecting hole and one Ø 11 mm connecting hole. Adjustable for 60-130 mm pipe diameter. The connecting tab is designed so that any of the following may be used as cable holders:

- terminal block tab type 324/S
- one-piece connector type 5001/DIN

Type	Material	Pack qty	Weight kg/100	Order no.
301/V	FS	5	11.900	5350867
301/V-VA	V2A	5	11.800	5350905

Terminal block tabs

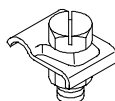

9

324/S

To guide, clamp and hold round conductors Rd 8 and Rd 10 to gutter downpipe brackets, steel structures, etc.

Prefitted with M8 x 25 hexagon head screw, nut and serrated lock washer
Material: stainless steel

Type	To fit mm	Material	Pack qty	Weight kg/100	Order no.
324/S	Rd 8-10	FT	50	3.400	5326303
324/S-VA	Rd 8-10	VA	50	3.400	5326311

Test joints

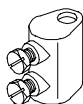

10

223/DIN

DIN 48835, Form A

Pack: 50

Suitable for round conductor Rd8/Rd10 with round conductor Rd 16, fitted with hexagon head screws, DIN 48835, Form A, closed design
Clamp body of die-cast zinc, screws of stainless steel

Type	To fit mm	Material	Pack qty	Weight kg/100	Order no.
223/DIN	8-10/16	Zn	50	12.850	5335205

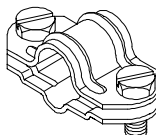

10

226

Type	To fit mm	Material	Pack qty	Weight kg/100	Order no.
226	8-10/FL30 x 16	FT	50	8.600	5336007
226/Cu	8-10/FL30 x 16	Cu	50	9.700	5336023
226/VA	8-10/FL30 x 16	VA	50	8.700	5336058

Rod holders

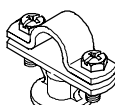

11

113/Z-16

For lightning rods and earth entry bar 16 mm Ø, fitted with 2 hexagon head screws DIN 84/M6 x 16, hot-dip galvanised. With M8 female thread for mounting. The through hole can be used for fixing with woodscrews.

Material: crossbar and screws of galvanised steel, lower part of die-cast zinc.

Type	To fit mm	Material	Pack qty	Weight kg/100	Order no.
113/Z-16	Rd 16	Zn	50	6.000	5412609

Rod holders

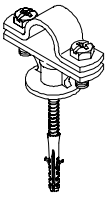

11

113/B-Z-HD-16

For lightning rods and earth entry bars Rd 16, with crossbar, fitted with 2 M6 x 16 hexagon head screws, of stainless steel VA (1.4303), 5 x 60 woodscrew and 8 mm plastic plug

Type	To fit mm	Material	Pack qty	Weight kg/100	Order no.
113/B-Z-HD-16	Rd 16	Zn	100	6.880	5412803

Earth entry bars



12

200

Rounded both ends, 16 mm Ø
Material: steel, hot-dip galvanised

Type	Length mm	Nom. size Ø mm	Pack qty	Weight kg/100	Order no. FT
200	1500	16	10	242.000	5420156
200	2000	16	10	320.000	5420202

Cross-connectors

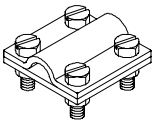

13

252/16-FL

To connect strap conductor (30 x 3.5) to earth entry bar (Ø 16 mm), fitted with hexagon head screws

Type	To fit mm	Material	Pack qty	Weight kg/100	Order no.
252/DIN	8-10, FL30x16	FT	25	38.000	5312345
252/DIN	8-10 x 8-10	FT	25	33.530	5312310

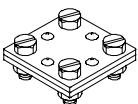

14

256/...

DIN 48845, Form H for strap conductor up to FL40

To fit: max. FL30 x max. FL30,
max. FL40 x max. FL40

without intermediate plate, with 4 M8 x 25 hexagon head screws and 4 M8 hexagon nuts

Type	Material	To fit mm	Pack qty	Weight kg/100	Order no.
256/A-DIN	FT	max. FL 30	10	10.260	5314658
256/B-A-DIN 30	VA	max. FL 30	25	27.800	5314720

Strap conductors

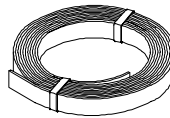

15

5052

Material: steel, hot-dip galvanised/stainless steel

Zinc coating: 500 g/m²

Dimensions: 30 x 3.5 mm

Type	Material	Standard coil m approx	Weight kg/100 m	Order no.
5052	FT	100	84.000	5020336
5052	FT	FIX 25	84.000	5020832
5052	FT	FIX 50	84.000	5020956
5052/V2A	V2A	50	84.000	5018501
5052/V4A	V4A	50	84.000	5018706

Equipotential bonding bar

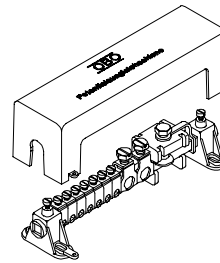

16

1801 VDE

With 10 x 10 mm terminal rail of nickel-plated brass and terminals of electro-galvanised steel, protected from accidental contact. Cover 217 x 63 x 65.5 mm of impact-resistant polystyrene

Colour: grey, RAL 7035

Possible connections:

7 conductors 2.5-25 mm²

2 conductors 25-95 mm²

1 conductor (strap conductor) 4 x 30 mm

Components for on-site assembly of equipotential bonding bars can be supplied

Type	Pack qty	Weight kg each	Order no.
1801 VDE	1	0.550	5015650

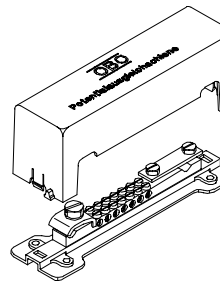

16

Design 1809/A for outdoor use

Possible connections to equipotential bonding bar

7 solid or stranded conductors up to 25 mm²

or multi-stranded conductors 16 mm²

1 round conductor Rd 8-10

1 strap conductor FL 30 or round conductor Rd 8-10

Type	Pack qty	Weight kg each	Order no.
1809	1	0.370	5015073
1809/A	1	0.370	5015111

Pipe clips

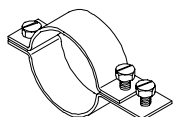

17

303/DIN

DIN 48818, Form D
Fitted with 2 DIN 933/M8 x 20 hexagon head screws and
2 DIN 934/M8 hexagon nuts, hot-dip galvanised
Material: steel, hot-dip galvanised

Type	For pipe inch	Pack qty	Weight kg/100	Order no. FT
303/DIN	3/4	5	25.640	5102081
303/DIN	1	5	28.300	5102111
303/DIN	1 1/4	5	31.300	5102138
303/DIN	1 1/2	5	33.220	5102154
303/DIN	2	5	36.840	5102197

Connection clamps

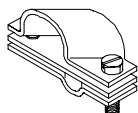

18

2760/20

Pack: 5
For earthing rods of hot-dip galvanised steel
Possible connections: flat strip up to 40 mm, round conductor Rd 10
Material: hot-dip galvanised steel

Type	For deep earthing rods Ø mm	Material	To fit mm	Pack qty	Weight kg each	Order no.
2760/20	20	FT	8-10/FL40	5	0.324	5001641
2760/20-VA	20	V2A	8-10/FL40	5	0.324	5001625

Earthing rods



19

219/20 BP

DIN 48852, Form Z
System "BP", with pin and bore,
219/20 BP: zinc coating, min. 60 µm

Type	Length supplied mm	Material	Pack qty	Weight kg each	Order no.
219/20 BP	1500	FT	5	3.650	5000947
219/20 BP-VA	1500	V4A	5	3.650	5000866

Earthing rods



19

219/20

DIN 48820, Form Z
System "OMEX", with pin and bore
Zinc coating, min. 60 µm

Type	Length supplied mm	Material	Pack qty	Weight kg each	Order no.
219/20	1500	FT	5	3.650	5000017

Driving pins

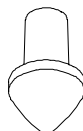

20

1819/20 BP

DIN 48852, Form Sp
For earthing rods, system "BP"

19

Type	For deep earthing rods Ø mm	Pack qty	Weight kg each	Order no. TG
1819/20BP	20	10	0.035	3041212



20

1819/20

DIN 48852, Form Sp
For earthing rods, system "OMEX"

19

Type	For deep earthing rods Ø mm	Pack qty	Weight kg each	Order no. TG
1819/20	20	10	0.033	3041204

Spacer

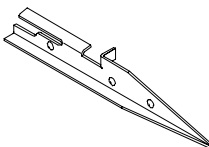

21

1811

DIN 48833 for foundation earth conductor
Pack: 25

Type	To fit mm	Length mm	Pack qty	Weight kg each	Order no. FT
1811	10/FL30x3.5	250	25	0.190	5014018

OBO wedge connectors

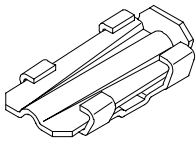

22

1813/DIN
DIN 48834, Form A

Type	To fit mm	Pack qty	Weight kg each	Order no. FT
1813/DIN	10/FL30 x FL30	5	0.200	5014212

Connecting and bridging components

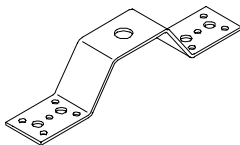

23

288/DIN
DIN 48841, Form B

Type	Pack qty	Weight kg/100	Order no. Alu
288/DIN	50	7.500	5320712

To be used with: Connector 5001 30 Order no. 5304164

Connecting components

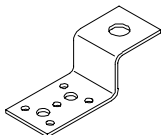

24

287/DIN
DIN 48841, Form L

Type	Material	Pack qty	Weight kg/100	Order no.
287	Alu	50	6.000	5320704

To be used with: Connector 5001 30 Order no. 5304164

Saddle terminals

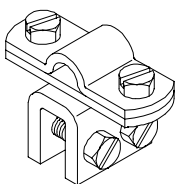

25

270
Pack: 50

Type	For welt thickness mm	Material	Pack qty	Weight kg/100	Order no.
270	max. 10	FT	50	13.810	5317207

Saddle terminals

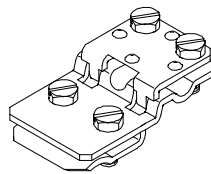

25

274
Further information on our tested lightning protection components to EN 50164-1 is available on request

Type	For welt thickness mm	Material	Pack qty	Weight kg/100	Order no.
274	max. 10	FT	50	10.400	5317428

Roof cable holders

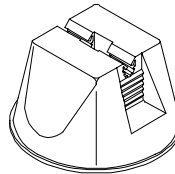

26

165/MBG
DIN 48829, Form B1
Filled with concrete, frost-resistant

Type	To fit mm	Pack qty	Weight kg/100	Order no. PE/PP
165/MBG	Rd 8	12	106.000	5218691
165/MBG	Rd 10	12	106.000	5218675

Stands

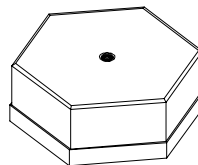

27

101/ST
Concrete, frost-resistant, M16 female thread
Recommended length of lightning rod with 101/ST max. 1.0 m 28

Type	Pack qty	Weight kg/100	Order no.
101/ST	4	6.900	5402891

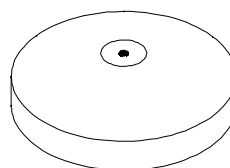

27

101/B-16
Concrete, frost-resistant, M16 female thread
Recommended length of lightning rod 2.5 m 28

Type	Pack qty	Weight kg/100	Order no.
101/B-16	1	16.000	5402956

Lightning rods



28

101/ALU
16 mm Ø
DIN 48802, Form A1

Type	Length mm	Nom. size Ø mm	Pack qty	Weight kg/100	Order no. Alu
101/ALU	1000	16	10	55.000	5401771
101/ALU	1500	16	10	81.000	5401801
101/ALU	2000	16	10	109.000	5401836
101/ALU	2500	16	10	136.000	5401852
101/ALU	3000	16	5	162.000	5401879

Screwless cable holders

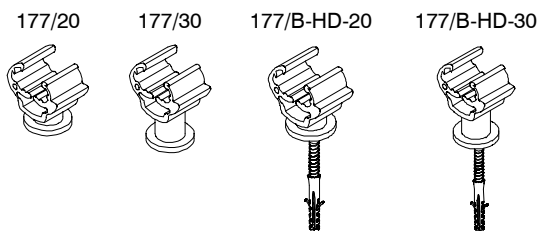

31

177/...-DIN
DIN 48838, similar to Form B

Type	To fit mm	Carton qty	Pack qty	Weight kg/100	Order no. PA
177/20-DIN	Rd 8-10	500	50	1.050	5207444
177/30-DIN	Rd 8-10	500	50	1.200	5207460
177/B-HD-20	Rd 8-10		100	1.930	5207851
177/B-HD-30	Rd 8-10		100	2.080	5207878

Flexible anti-corrosion bandages



356

29

Type	Width mm	Length m	Pack qty	Weight kg each	Order no.
356	50	10	1	0.715	2360055

Expansion piece

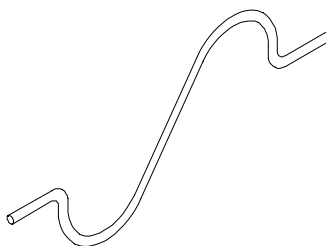

32

172/AR
Similar to DIN 48842

Type	Pack qty	Weight kg/100	Order no. Alu
172/AR	25	7.500	5218926

Connectors

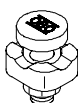

30

5001/DIN
DIN 48837, Form A

Type	To fit mm	Material	Pack qty	Weight kg/100	Order no.
5001/DIN	Rd 8-10	Zn/FT	100	7.450	5304105

Jumper cable

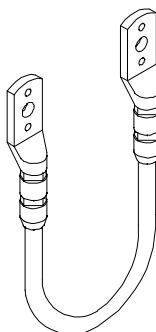

33

853/DIN: DIN 48841, Form D
Steel cable 25 mm² with black plastic covering, cable lugs of aluminium with 1 fixing hole Ø 8.5 and 2 fixing holes Ø 4.2

Type	Pack qty	Weight kg/100	Order no. Alu
853/DIN	100	7.260	5331013

Which lightning arrester and when?

Because of its lightning current discharge capacity ($25kA_{\text{four-pole}}$ (10/350)), the **V 25-B** should be used in small buildings. Its low protection level means that the V 25-B can also be used as a B and C combination arrester. According to the VDS (German Association of Property Insurers), use in buildings is permitted. For example detached houses, small workshops, etc.

Compared with the V 25-B, LightningController **MC 50-B VDE** has a higher lightning current discharge capacity ($50 kA_{\text{single pole}}$ (10/350)) and is mainly used in industrial plants. A further possible site is buildings assigned to one of the lightning protection classes to IEC 61024-1.

For example public buildings, churches, industrial plants, department stores, meeting halls, etc.

For wiring guidance see page 4.

OBO lightning arresters

LightningController (requirement class B)

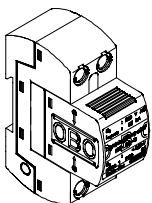

34



MC 50-B VDE:

The plug-in multiple spark gap of the OBO MC 50-B VDE is a lightning arrester of requirement class B to DIN VDE 0675 Part 6 (draft 11.89), as well as Class I to IEC 61643-1 (02.98) and is designed to be used between interfaces 0_A to 1 according to the lightning protection zone concept set out in IEC 1312-1.

• The requirements for the testability of class B surge protection devices in the VDEW guideline (first edition 1998) are comprehensively met by the use of a plug-in upper part.

Since the spark gap of the device is enclosed, **no plasma arcs are produced outside the casing**. This means that the lightning arrester may be mounted on a standard NS 35 rail in a commercially available consumer unit.

Type	Pack qty	Weight kg each	Order no.
MC 50-B VDE	1	0.400	5096847

Upper and lower part

OBO lightning arresters

LightningController (requirement class B)

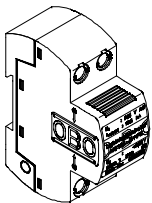

34



MC 125-B/NPE:

The OBO type MC 125-B/NPE LightningController was designed to be used in TN-S, TT and IT systems as a sum current spark gap between the neutral conductor (N) and the protective earth conductor (PE).

It meets the requirements of requirement class B of DIN VDE 0675 Part 6 (draft 11.89), as well as class I of IEC 61643-1 (02.98) and is designed to be used between interfaces 0_A to 1 according to the lightning protection zone concept set out in IEC 1312-1.

In conjunction with OBO LightningController MC 50-B VDE and in the presence of a lightning protection system for the building or overhead power lines, the MC 125-B/NPE establishes lightning protection potential equalisation.

The requisite tests have been performed with reference to the lightning current parameters according to ENV 61024-1 and IEC 1024-1.

Type	Pack qty	Weight kg each	Order no.
MC 125-B/NPE	1	0.520	5096863

OBO lightning arresters (requirement class B)

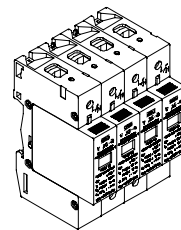
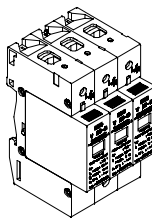

35

V 25-B: (for TN-C, TN-S systems)

Lightning arrester V 25-B is intended for use in lightning protection potential equalisation to VDE 0185, Part 1, as well as Part 100. It is an arrester of requirement class B to DIN VDE 0675, Part 6 (Draft 11.89), the purpose of which is to establish lightning protection potential equalisation for the power supply line in the presence of a lightning protection system for the building. It should also be used in buildings supplied via an overhead line, since direct lightning or partial lightning currents may be expected here as well. OBO lightning arrester V 25-B has a built-in isolating device with defect indication, so that a faulty arrester module can be replaced without removing the connecting wires and switching off the power.

To measure the insulation, simply withdraw the upper part of the V 25-B.

Type	Pack qty	Weight kg each	Order no.
V 25-B/3 (TN-C)	1	0.435	5097002
V 25-B/4 (TN-S)	1	0.630	5097037

For 230/400 V systems

Upper and lower part

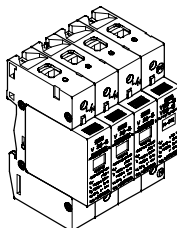

35

V 25-B/3+NPE: (for TT and IT systems)

Lightning arrester OBO V25-B/3+NPE for use in lightning protection potential equalisation for TT and IT systems.

Four-pole modular lightning arrester to a 17.5 mm module for special use in lightning protection potential equalisation for TN-S, TT and IT systems to VDE 0185, Part 1 and Part 100, ENV 61024-1, IEC 1024-1, as well as E DIN VDE 0100 Part 534/A1. The arrester modules are self-monitoring, thanks to a thermal isolating device with function indication. Varistor blocks can be withdrawn singly from the lower part without interrupting the voltage. Guide bars prevent unauthorised removal. The arrester can be upgraded for remote monitoring by means of an infrared light barrier. The arrester conforms to requirement class B of DIN VDE 0675, Part 6 and annexes.

Type	Pack qty	Weight kg each	Order no.
V 25-B/3+NPE	1	0.640	5097401

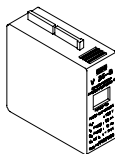

35

Type	Pack qty	Weight kg each	Order no.
V 25-B/0	1	0.095	5097053

For 230/400 V systems

Upper part

Wordings for use in tenders

- 1 Lightning rod**
to DIN 48802 Form A3, diameter 16 mm
Length 1000 mm, rounded on one side
The other side with forged-on tab and prefitted connector type 5001 DIN. Capable of carrying lightning current (10/350) to EN 50164-1, 100 kA (H)
for round conductor 8-10 mm diameter
Supply and install
Type: **101/G-DIN** Order no. **5402107**
- 1 Lightning rod**
to DIN 48802 Form A3, diameter 16 mm
Length 1500 mm, rounded on one side
The other side with forged-on tab and prefitted connector type 5001 DIN. Capable of carrying lightning current (10/350) to EN 50164-1, 100 kA (H)
for round conductor 8-10 mm diameter
Supply and install
Type: **101/G-DIN** Order no. **5402158**
- 2 Round conductor**
Aluminium, soft, twist quality
Diameter 8 mm
Supply and install
Type: **Rd 8/ALU-T** Order no. **5021294**
- 3 Roof cable holder**
Stainless-steel with polyamide cable holder type 177/20 for ridge tiles, width adjustable 160-260 mm
Supply and install
Type: **132/K-VA** Order no. **5202515**
- 3 Roof cable holder**
Stainless-steel, copper-plated, with cable holder of copper-coloured polyamide type 177/20-CU for ridge tiles, width adjustable 160-260 mm
Supply and install
Type: **132/K-CU** Order no. **5202590**
- 4 Roof cable holder**
Straight, stainless-steel, for tiled roofs, with polyamide cable holder type 177/20 grey. Length 230 mm
Supply and install
Type: **157/FK-VA** Order no. **5215544**
- 4 Roof cable holder**
Straight, stainless-steel, for tiled roofs with polyamide cable holder type 177/20 grey. Length 280 mm
Supply and install
Type: **157/FK-VA** Order no. **5215587**
- 4 Roof cable holder**
Straight, stainless-steel, for tiled roofs, with polyamide cable holder type 177/20 grey. Length 410 mm
Supply and install
Type: **157/FK-VA** Order no. **5215609**
- 4 Roof cable holder**
Straight, stainless-steel for slate roofs, with polyamide cable holder type 177/20 grey. Length 212 mm
Supply and install
Type: **157/FK-VA** Order no. **5215374**
- 5 Vario quick connector**
Hot-dip galvanised steel, to connect 8 and 10 mm round conductors for parallel, T and cross connections, capable of carrying lightning current (10/350) to EN 50164-1, 100 kA (H)
Supply and install
Type: **249/ST** Order no. **5311500**
- 5 Vario quick connector**
Aluminium, to connect 8 and 10 mm round conductors for parallel, T and cross connections, capable of carrying lightning current (10/350) to EN 50164-1, 100 kA (H)
Supply and install
Type: **249/Alu** Order no. **5311519**
- 5 Vario quick connector**
Stainless-steel, material 1.4301, to connect 8 and 10 mm round conductors for parallel, T and cross connections, capable of carrying lightning current (10/350) to EN 50164-1, 100 kA (H)
Supply and install
Type: **249/VA** Order no. **5311551**
- 6 Gutter clip**
Hot-dip galvanised steel, to connect cables to gutters, suitable for edge bead thickness 15-22 mm, with stainless-steel screws
Supply and install
Type: **262/A DIN** Order no. **5216219**
- 6 Gutter clip**
Steel, hot-dip galvanised to DIN ISO 1461, to connect 8-10 mm round conductors to gutters, suitable for all edge bead thicknesses, with stainless-steel screws
Supply and install
Type: **262** Order no. **5216014**
- 6 Gutter clip**
To connect 8-10 mm round conductors of steel or aluminium to copper gutters, suitable for all edge bead thicknesses, with intermediate plate of aluminium/copper and crossbar of steel, lower part of copper
Supply and install
Type: **262/ZM** Order no. **52161700**
- 7 Cable holder**
Lower part of die-cast zinc, with M8 female thread and crossbar of hot-dip galvanised steel, with 2 M6 x 16 hexagon head screws
Supply and install
Type: **113/Z 8-10** Order no. **5229960**

7 Cable holder

Lower part of die-cast zinc, with M8 female thread and crossbar of hot-dip galvanised steel, with 2 prefitted M6 x 16 hexagon head screws, with 5 x 60 woodscrew and 8 mm plastic plug
Supply and install
Type: **113/Z-HD 8-10** Order no. **5230322**

8 Gutter downpipe bracket

Hot-dip galvanised steel, to carry 8-10 mm round conductors directly behind the downpipe, including screws and nuts, for pipe diameter 100 mm
Supply and install
Type: **301/S** Order no. **5351057**

8 Gutter downpipe bracket

Hot-dip galvanised steel, to carry 8-10 mm round conductors directly behind the downpipe, including screws and nuts, for pipe diameter 120 mm
Supply and install
Type: **301/S** Order no. **5351073**

8 Gutter downpipe bracket

Hot-dip galvanised steel, with two 7 mm Ø connecting holes, one 9 mm Ø connecting hole and one 11 mm Ø connecting hole. Adjustable for downpipes with diameters from 60 to 130 mm
Supply and install
Type: **301/V** Order no. **5350867**

8 Gutter downpipe bracket

Aluminium, with two 7 mm Ø connecting holes, one 9 mm Ø connecting hole and one 11 mm Ø connecting hole. Adjustable for downpipes with diameters from 60 to 130 mm
Supply and install
Type: **301/V-AL** Order no. **5350921**

9 Terminal block tab

Steel, hot-dip galvanised
To clamp 8-10 mm round conductors to gutter downpipe brackets or to steel structures, complete with M8 x 25 hexagon head screw, nut and serrated lock washer, stainless-steel
Supply and install
Type: **324/S** Order no. **5326303**

9 Terminal block tab

Stainless-steel, material 1.4301, to clamp 8-10 mm round conductors to gutter downpipe brackets or to steel structures, complete with M8 x 25 hexagon head screw
Supply and install
Type: **324/S-VA** Order no. **5326311**

10 Test joint

To DIN 48835, Form A, of die-cast zinc, with stainless-steel screws, to connect 8-10 mm round conductors to 16 mm round earth entry bar
Tested to EN 50164-1
Supply and install
Type: **223/DIN** Order no. **5335205**

10 Test joint

Hot-dip galvanised steel, to connect round conductors Rd 8-10 and strap conductors FL 30 to earth entry bar Rd 16, capable of carrying lightning current (10/350) to EN 50164-1, 100 kA (H)
Supply and install
Type: **226** Order no. **5336007**



10 Test joint

Copper, to connect round conductors Rd 8-10 and strap conductors FL 30 to earth entry bar Rd 16, capable of carrying lightning current (10/350) to EN 50164-1, 100 kA (H)
Supply and install
Type: **226/Cu** Order no. **5336023**



10 Test joint

Stainless-steel, material 1.4301, to connect round conductors Rd 8-10 and strap conductors FL 30 to earth entry bar Rd 16, capable of carrying lightning current (10/350) to EN 50164-1, 100 kA (H)
Supply and install
Type: **226/VA** Order no. **5336058**



11 Rod holder

Lower part of die-cast zinc, to secure lightning rods and earth entry bars, 16 mm diameter, M8 female thread, crossbar of hot-dip galvanised steel, fitted with 2 M6 x 16 hexagon head screws
Supply and install
Type: **113/Z-16** Order no. **5412069**

11 Rod holder

Lower part of die-cast zinc, to secure lightning rods and earth entry bars, 16 mm diameter, M8 female thread, crossbar of hot-dip galvanised steel, fitted with 2 M6 x 16 hexagon head screws, prefitted with 5 x 60 woodscrew and 8 mm plastic plug
Supply and install
Type: **113/B-Z-HD-16** Order no. **5412803**

12 Earth entry bar

Hot-dip galvanised, 16 mm diameter, rounded both sides, to connect the down conductor to the earthing installation
Supply and install
Type: **200** Order no. **5420156**

12 Earth entry bar

Hot-dip galvanised, 16 mm diameter, rounded both sides, to connect the down conductor to the earthing installation, length 2000 mm.
Supply and install
Type: **200** Order no. **5420202**

13 Cross-connector

Hot-dip galvanised steel, 60 x 60 mm with intermediate plate, M8 x 25 screws (slotted) and nuts to connect 8-10 mm round conductor to 8-10 mm round conductor with intermediate plate
Supply and install
Type: **252/DIN** Order no. **5312310**

14 Cross-connector

Hot-dip galvanised steel, 30 x 30 mm without intermediate plate, including M8 x 25 screws (slotted) and nuts to connect FL30 strap conductor in the earth.

Supply and install

Type: **256/A-DIN 30** Order no. **5314658**

14 Cross-connector

Hot-dip galvanised steel, 60 x 60 mm without intermediate plate, including M8 x 25 screws (slotted) and nuts to connect FL30 strap conductor in the earth

Supply and install

Type: **256/B-A-DIN 30** Order no. **5314720**

15 Strap conductor

For setting up earthing installations and for use in lightning protection, steel, hot-dip galvanised

Dimensions W x H: 30 x 3.5 mm

Zinc coating: 225 g/m² (approx 30 µm)

Fixed length: 100 m, coiled

Supply and install

Type: **5052** Order no. **5020336**

15 Strap conductor

For setting up earthing installations and for use in lightning protection, steel, hot-dip galvanised

Dimensions W x H: 30 x 3.5 mm

Zinc coating: 225 g/m² (approx 30 µm)

Fixed length: 25 m, coiled

Supply and install

Type: **5052** Order no. **5020832**

15 Strap conductor

For setting up earthing installations and for use in lightning protection, steel, hot-dip galvanised

Dimensions W x H: 30 x 3.5 mm

Zinc coating: 225 g/m² (approx 30 µm)

Fixed length: 50 m, coiled

Supply and install

Type: **5052** Order no. **5020956**

15 Strap conductor

For setting up earthing installations and for use in lightning protection, stainless-steel V2A, material 1.4301

Dimensions W x H: 30 x 3.5 mm

Fixed length: 50 m, coiled

Supply and install

Type: **5052** Order no. **5018501**

15 Strap conductor

For setting up earthing installations and for use in lightning protection, stainless-steel V4A, material 1.4571

Dimensions W x H: 30 x 3.5 mm

Fixed length: 50 m, coiled

Supply and install

Type: **5052** Order no. **5018706**

16 Equipotential bonding bar

Tested to VDE 0618 Part 1, consisting of 10 x 10 mm nickel-plated brass terminal rail, electro-galvanised steel terminals protected from accidental contact, rail holders and cover. Also suitable for potential equalisation for lightning protection. Fitted with terminals for:

7 solid, stranded or multi-stranded conductors 2.5-25 mm²,

2 solid, stranded or multi-stranded conductors 25-95 mm²,

1 strap conductor up to FL30, max. thickness 5 mm

Tested to EN 50164-1

Supply and install

Type: **1801 VDE** Order no. **5015650**

16 Equipotential bonding bar

Consisting of nickel-plated brass contact rail, electro-galvanised steel screws and crossbars, and polystyrene base and cover. Fitted with terminals for:

7 solid, stranded or multi-stranded conductors 2.5-25 mm²,

1 Rd 8-10 round conductor,

1 strap conductor up to FL30

Tested to EN 50164-1

Supply and install

Type: **1809** Order no. **5015073**

16 Equipotential bonding bar

For outdoor use, consisting of nickel-plated contact rail, stainless steel screws and crossbars, and polystyrene base and cover, colour: black, UV-resistant. Fitted with terminals for:

7 solid, stranded or multi-stranded conductors 2.5-25 mm²,

1 Rd 8-10 round conductor,

1 strap conductor up to FL30

Tested to EN 50164-1

Supply and install

Type: **1809/A** Order no. **5015111**

17 Pipe clip

Hot-dip galvanised steel, to DIN 48818, Form D, width 40 mm with hole Ø = 11 mm, prefitted with M8 x 25 screws (slotted) and M8 nuts, for pipe diameter 3/4" = 26.9 mm

Supply and install

Type: **303/DIN** Order no. **5102081**

17 Pipe clip

Hot-dip galvanised steel, to DIN 48818, Form D, width 40 mm with hole Ø = 11 mm, prefitted with M8 x 25 screws (slotted) and M8 nuts, for pipe diameter 1" = 33.7 mm

Supply and install

Type: **303/DIN** Order no. **5102111**

17 Pipe clip

Hot-dip galvanised steel, to DIN 48818, Form D, width 40 mm with hole Ø = 11 mm, prefitted with M8 x 25 screws (slotted) and M8 nuts, for pipe diameter 1 1/4" = 42.4 mm

Supply and install

Type: **303/DIN** Order no. **5102138**

17 Pipe clip

Hot-dip galvanised steel, to DIN 48818, Form D, width 40 mm with hole $\varnothing = 11$ mm, prefitted with M8 x 25 screws (slotted) and M8 nuts, for pipe diameter $1\frac{1}{2}'' = 48.3$ mm
Supply and install
Type: **303/DIN** Order no. **5102154**

17 Pipe clip

Hot-dip galvanised steel, to DIN 48818, Form D, width 40 mm with hole $\varnothing = 11$ mm, prefitted with M8 x 25 screws (slotted) and M8 nuts, for pipe diameter $2'' = 60.3$ mm
Supply and install
Type: **303/DIN** Order no. **5102197**

18 Connection clamp

Hot-dip galvanised steel with intermediate plate to connect Rd 8-10 round conductor or strap conductor up to FL 40 to earthing rods (deep earthing rods) with a diameter of 20 mm, prefitted with screws (slotted) and nuts
Supply and install
Type: **2760/20** Order no. **5001641**

18 Connection clamp

Stainless steel, material 1.4301 with intermediate plate to connect Rd 8-10 mm round conductor or strap conductor up to 4 x 40 mm to earthing rods (deep earthing rods) with a diameter of 20 mm, prefitted with screws (slotted) and nuts
Supply and install
Type: **2760/B-20-VA** Order no. **5001625**

19 Earthing rod

To DIN 48852, Form Z, hot-dip galvanised steel, zinc coating at least $60 \mu\text{m}$, "BP" system with pin and bore as coupling, diameter 20 mm
Length supplied 1500 mm
Supply and install
Type: **219/20 BP** Order no. **5000947**

19 Earthing rod

To DIN 48852, Form Z, hot-dip galvanised steel, zinc coating at least $60 \mu\text{m}$, "OMEX" system with pin and bore as coupling, diameter 20 mm
Length supplied 1500 mm
Supply and install
Type: **219/20** Order no. **5000017**

19 Earthing rod

To DIN 48852, Form Z, stainless-steel V4A, material 1.4571, "BP" system with pin and bore as coupling, diameter 20 mm. Length supplied 1500 mm
Supply and install
Type: **219/20 BP-VA** Order no. **5000866**

20 Driving pins

(to DIN 48852) of malleable cast iron
Form Sp for deep earthing rods $\varnothing = 20$ mm, "BP" system
Supply and install
Type: **1819/20BP** Order no. **3041212**

20 Driving pins

(to DIN 48852) of malleable cast iron
Form Sp for deep earthing rods $\varnothing = 20$ mm, "OMEX" system
Supply and install
Type: **1819/20BP** Order no. **3041204**

21 Spacer

Hot-dip galvanised steel for professional installation of 10 mm round steel or 30 x 3.5 mm flat steel foundation earth, length 250 mm with depth stop
Supply and install
Type: **1811** Order no. **5014018**

22 Wedge connector

Hot-dip galvanised steel to DIN 48834 Form A, suitable for cross, longitudinal and T connections in the foundations, for Rd 10 round steel or 30 x 3.5 mm flat steel
Supply and install
Type: **1813DIN** Order no. **5014212**

23 Connecting and bridging component

Aluminium, to DIN 48841 Form B, to connect round and strap conductors to steel and sheet metal structures.
Connection hole $\varnothing = 11$ mm; 5 fixing holes $\varnothing = 4.2$ mm and 2 fixing holes $\varnothing = 6.9$ mm on each side
Supply and install
Type: **288/DIN** Order no. **5320712**

24 Connecting component

Aluminium, to DIN 48841 Form L, to connect round and strap conductors to steel and sheet metal structures.
Connection hole $\varnothing = 11$ mm; 5 fixing holes $\varnothing = 4.2$ mm and 2 fixing holes $\varnothing = 6.9$ mm
Supply and install
Type: **287** Order no. **5320704**

25 Saddle terminal

Hot-dip galvanised steel, to connect Rd 8-10 round conductors to sheet metal and steel structures up to 10 mm thick, with 2 hexagon head screws for clamping and 2 hexagon head screws on the crossbar, M6 (slotted)
Capable of carrying lightning current (10/350) to EN 50164-1, 100 kA (H)
Supply and install
Type: **270** Order no. **5317207**



25 Saddle terminal

Hot-dip galvanised steel, for parallel and cross connection of 8-10 mm round conductors to sheet metal and steel structures up to 10 mm thick
Capable of carrying lightning current (10/350) to EN 50164-1, 100 kA (H)
Supply and install
Type: **274** Order no. **5317207**



26 Roof cable holder

(to DIN 48829) of plastic, Form B1, for the installation of lightning conductor cables on flat roofs, for Rd 8 round conductor, with frost-resistant concrete filling, fill weight 1 kg. Sheath of polyethylene, floor of polypropylene, black, UV resistant
Supply and install
Type: **165/MBG** Order no. **5217428**

26 Roof cable holder

(to DIN 48829) of plastic, Form B1, for the installation of lightning conductor cables on flat roofs, for Rd 10 round conductor, with frost-resistant concrete filling, fill weight 1 kg, black, UV resistant
Supply and install
Type: **165/MBG** Order no. **5218675**

27 Stand

Frost-resistant concrete, with lower part of plastic M16 female thread to accept lightning rod up to 1 metre long
Weight 6.9 kg each
Supply and install
Type: **101/St** Order no. **5402891**

27 Stand

Frost-resistant concrete, M16 female thread to accept lightning rod up to 2.5 metres long
Weight 16 kg each
Supply and install
Type: **101/B-16** Order no. **5402956**

28 Lightning rod

(to DIN 48802 Form A1) aluminium, diameter 16 mm, with M16 x 35 thread to screw into stand with M16 female thread, length 1000 mm
Supply and install
Type: **101/ALU** Order no. **5401771**

28 Lightning rod

(to DIN 48802 Form A 1) aluminium, diameter 16 mm, with M16 x 35 thread to screw into stand with M16 female thread, length 1500 mm
Supply and install
Type: **101/ALU** Order no. **5401801**

28 Lightning rod

(to DIN 48802 Form A1) aluminium, diameter 16 mm, with M16 x 35 thread to screw into stand with M16 female thread, length 2000 mm
Supply and install
Type: **101/ALU** Order no. **5401836**

28 Lightning rod

(to DIN 48802 Form A1) aluminium, diameter 16 mm, with M16 x 35 thread to screw into stand with M16 female thread, length 2500 mm
Supply and install
Type: **101/ALU** Order no. **5401852**

28 Lightning rod

(to DIN 48802 Form A1) aluminium, diameter 16 mm, with M16 x 35 thread to screw into stand with M16 female thread, length 3000 mm
Supply and install
Type: **101/ALU** Order no. **5401879**

29 Anti-corrosion bandages

Of cotton fabric with petroleum jelly, to be wrapped around clamping and connection points in the ground for protection; 1.2 mm thick and 50 mm wide
Supply and install
Type: **356** Order no. **2360055**

30 Connector

(to DIN 48837), Form A, screw of hot-dip galvanised steel, clamp part of die-cast zinc, as connection component for Rd 8-10 round conductor, capable of carrying lightning current (10/350) to EN 50164-1, 100 kA (H)
Supply and install
Type: **5001/DIN** Order no. **5304105**



31 Screwless cable holder

Polyamide, for the installation of Rd 8-10 round conductors, with M8 female thread and through hole for wood-screws, weather and temperature resistant from -35°C to +90°C, mounting height 20 mm
Supply and install
Type: **177/20-DIN** Order no. **5207444**

31 Screwless cable holder

Polyamide, for the installation of Rd 8-10 round conductors, with M8 female thread and through hole for wood-screws, weather and temperature resistant from -35°C to +90°C, mounting height 30 mm
Supply and install
Type: **177/30-DIN** Order no. **5207460**

31 Screwless cable holder

Polyamide, for the installation of Rd 8-10 round conductors, with M8 female thread and through hole for wood-screws, weather and temperature resistant from -35°C to +90°C, mounting height 20 mm, prefitted with 5 x 60 mm woodscrew and 8 x 40 mm plastic plug
Supply and install
Type: **177/B-HD-20** Order no. **5207851**

31 Screwless cable holder

Polyamide, for the installation of Rd 8-10 round conductors, with M8 female thread and through hole for wood-screws, weather and temperature resistant from -35°C to +90°C, mounting height 30 mm, prefitted with 5 x 60 mm woodscrew and 8 x 40 mm plastic plug
Supply and install
Type: **177/B-HD-30** Order no. **5207878**

32 Expansion piece

Aluminium, to compensate for changes of length due to temperature variations on the roof with conductor lengths of more than 20 metres. Length about 400 mm, Rd 8 round conductor
Supply and install
Type: **172/AR** Order no. **5218926**

33 Jumper cable

(to DIN 48841 Form D), steel, to bridge expansion gaps and butt joints, steel cable 25 mm², black plastic covering, with aluminium cable lugs, 1 fixing hole Ø = 8.5 mm and 2 fixing holes Ø = 4.2 mm
Supply and install
Type: **853/DIN** Order no. **5331013**

34 Lightning arrester

Requirement class B to E DIN VDE 0675 Part 6 (A1/A2)
 Multiple spark gap without blow-out,
 no plasma arcs produced outside the casing
 With VDE, ÖVE, KEMA KEUR approval marks,
 single-pole
 Rated/design voltage 230 V/ 255 V 50-60 Hz
 Lightning current discharge cap. 50 kA (10/350)
 Protection level < 2 kV
 Mains follow-up current quenching 25 kA
 Max. required series fuse 500 A
 Plug-in upper part allows insulation resistance to be checked without interrupting the voltage (TAB guideline), fully enclosed spark gap, snap fits to EN 50022 top-hat rail
 2 connection possibilities each for L and N/PE conductors
 Make: OBO Bettermann
 Type: **MC 50-B VDE** Order no. **5096847**
 or equivalent

34 NPE sum current spark gap

Requirement class B to E DIN VDE 0675 Part 6 (A1/A2),
 for use between neutral conductor (N) and protective earth conductor (PE) to DIN VDE 100 Part 534,
 single-pole
 Rated/design voltage 230 V/ 255 V 50-60 Hz
 Lightning current discharge cap. 125 kA (10/350)
 Protection level < 2.5 kV
 Fully enclosed spark gap, snap fits to EN 50022 top-hat rail
 2 connection possibilities each for N and PE conductors
 Make: OBO Bettermann
 Type: **MC 125-B/NPE** Order no. **5096863**
 or equivalent

34 Lightning arrester

Requirement class B to E DIN VDE 0675 Part 6 (A1/A2),
 for use in lightning protection potential equalisation to DIN VDE 0185 Part 1/100, triple-pole
 Rated/design voltage 230 V/ 275 V 50-60 Hz
 Tot. disch. surge current (nom.) 75 kA (8/20)
 Limit disch. surge current (3-pole) 150 kA (8/20)
 Protection level < 2 kV
 Max. required series fuse 160 A
 The arrester is in two parts – arrester module and base
 The arrester module can be separated from the base without tools. It snap-fits to top-hat rail to EN 50022
 Optical function indication
 Make: OBO Bettermann
 Type: **V 25-B/3** Order no. **5097002**
 or equivalent

35 Lightning arrester

Requirement class B to E DIN VDE 0675 Part 6 (A1/A2),
 for use in lightning protection potential equalisation to DIN VDE 0185 Part 1/100, four-pole
 Rated/design voltage 230 V/ 275 V 50-60 Hz
 Tot. disch. surge current (nom.) 100 kA (8/20)
 Limit disch. surge current (4-pole) 200 kA (8/20)
 Protection level < 2 kV
 Max. required series fuse 160 A
 The arrester is in two parts - arrester module and base
 The arrester module can be separated from the base without tools. It snap fits to top-hat rail to EN 50022
 Optical function indication
 Make: OBO Bettermann
 Type: **V 25-B/4** Order no. **5097037**
 or equivalent

35 Lightning arrester

Universally suitable for TN-S, IT and TT systems, of requirement class B to E DIN VDE 0675 Part 6 (A1/A2),
 for use in lightning protection potential equalisation to DIN VDE 0185 Part 1/100, four-pole arrester (3 lightning arresters + NPE spark gap)
Lightning arresters (triple-pole)
 Rated/design voltage 230 V/ 275 V 50-60 Hz
 Total disch. surge current (nom.) 75 kA (8/20)
 Limit disch. surge current (3-pole) 150 kA (8/20)
 Protection level < 2 kV
 Max. required series fuse 160 A
NPE spark gap (single-pole)
 Rated/design voltage 230 V/ 255 V 50-60 Hz
 Nominal discharge surge current 50 kA (8/20)
 The arrester is in two parts – arrester module and base
 The arrester module can be separated from the base without tools. It snap fits to top-hat rail to EN 50022
 Optical function indication
 Make: OBO Bettermann
 Type: **V 25-B/3+NPE** Order no. **5097401**
 or equivalent

35 Lightning arrester

Requirement class B to E DIN VDE 0675 Part 6 (A1/A2),
 for use in lightning protection potential equalisation to DIN VDE 0185 Part 1/100
 Upper part
 Rated/design voltage 230 V/ 275 V 50-60 Hz
 Nominal discharge surge current 30 kA (8/20)
 Limit discharge surge current 60 kA (8/20)
 Protection level < 2 kV
 Max. required series fuse 160 A
 Upper part for use in arrester base, optical function indication
 Make: OBO Bettermann
 Type: **V 25-B/0** Order no. **5097053**
 or equivalent

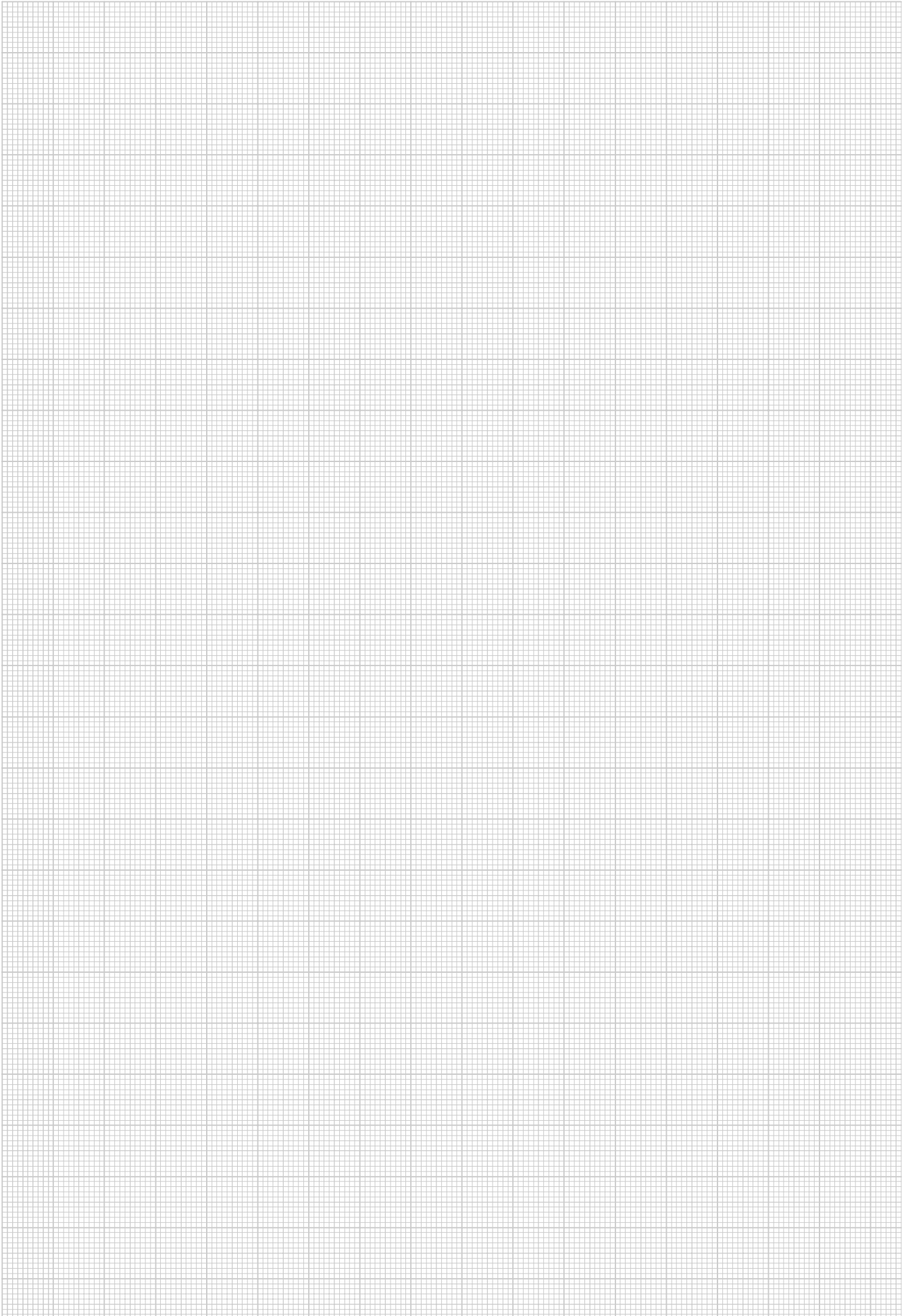

Test of lightning protection system
Test report no.:
Name of tester:

Done
by:

General information

Owner, name

Street

Postcode, town

Details of physical installation

Location

Lightning protection class (mark with cross)

I

II

III

IV

Design and use

Type of roof covering

Details of lightning protection system

Material and cross-section of the conductors

Lightning conductors

_____ (number)

Type of earthing installation:

e.g. ring earth, deep earth, foundation earth

Details of lightning protection potential equalisation

Proximities considered

yes

no

Shortcomings: see test result

Lightning protection standards and regulations at the time of installation

ABB 8th edition

DIN VDE 0185-1

DIN VDE 0185-2

VDE V 0185-100

DIN VDE 0185-103

Nature of test

Test of planning

Building-related test

Acceptance test

Repeat test

Supplementary test

Visual check

Complete test

In accordance with the standards

Testing by inspection for

- loose connections

- parts weakened by corrosion

- all earth connections

- fixings of all conductors and system components

- changes that require additional protection measures

- correct installation of all lightning and surge arresters

Testing by inspection for

- damage to or triggering of lightning or surge arresters _____
- blowing of series fuses before the arresters _____
- complete lightning protection potential equalisation for new supply connections or additions to supply connections inside the building installation, made since the last test _____

Measurements

- continuity of connections that are out of sight _____
- lightning collectors _____
- lightning conductors _____
- potential equalisation lines (guideline value 1 ohm) _____
- measurement of the contact resistance at all measurement points, in order to determine the continuity of the lines (guideline value 1 ohm) _____
- continuity to metallic installations (gas, water, heating, ventilation, etc.) _____

Test joint no.	1	2	3	4	5	6	7	8	9
R _A in ohms									
Test joint no.	10	11	12	13	14	15	16	17	18
R _A in ohms									
Test joint no.	19	20	21	22	23	24	25	26	27
R _A in ohms									

Propagation resistance R_{A tot} of the entire installation
 _____ Ohm
 with test joints closed

visual check by excavation yes no Position _____

Test result

The lightning protection system is satisfactory: yes no

The test revealed the following shortcomings:

Next test due

The test report contains _____ pages

The test report contains _____ annexes

Place _____, date: _____

 Signature of tester

 Signature of owner

Numerical list by order number

Structure of EAN number: country code **40** manufacturer's code **1219** individualised EAN **5647589**

EAN	Order no.	Price	Page	EAN	Order no.	Price	Page	EAN	Order no.	Price	Page	EAN	Order no.	Price	Page
		E				B									
5230533	2360055		17	5417675	5311500		12								
				5417736	5311519		12								
5242710	3041204		15	5417910	5311551		12								
5242772	3041212		15												
				5418092	5312310		14								
5371298	5000017		15	5418153	5312345		14								
5371830	5000866		15												
5371892	5000947		15			E									
				5419471	5314658		14								
5752653	5001625		15	5925873	5314720		14								
5372912	5001641		15			B									
				5419891	5316014		12								
5377894	5014018		15	5818359	5316170		12								
5378013	5014212		16												
				5420552	5317207		16								
5378259	5015073		14	5420859	5317428		16								
5959427	5015111		14												
5378556	5015650		14	5421573	5320704		16								
				5421634	5320712		16								
5800415	5018501		14												
5800477	5018706		14	5422419	5326303		13								
				5422471	5326311		13								
5380832	5020336		14												
5381372	5020832		14	5423379	5331013		17								
5381495	5020956		14												
				5423614	5335205		13								
5901273	5021294		12												
		G		5424215	5336007		13								
5966388	5096847		18	5424277	5336023		13								
5966449	5096863		18	5424338	5336058		13								
				5426790	5350867		13								
5808091	5097002		18	5426912	5350905		13								
5394037	5097037		18												
5394099	5097053		18	5426974	5351057		13								
5785590	5097401		18	5427032	5351073		13								
		B													
5399919	5102081		15	5901334	5401771		17								
5399971	5102111		15	5427810	5401801		17								
5400035	5102138		15	5427872	5401836		17								
5400097	5102154		15	5898399	5401852		17								
5400158	5102197		15	5902119	5401879		17								
				5428053	5402107		12								
5403036	5202515		12	5428176	5402158		12								
5902232	5202590		12	5428534	5402891		16								
				5897910	5402956		16								
5404897	5207444		17												
5404958	5207460		17	5429616	5412609		13								
5336433	5207851		17	5752356	5412803		14								
5334811	5207878		17												
				5429791	5420156		14								
5811879	5215374		12	5429913	5420202		14								
5902591	5215544		12												
5812296	5215587		12												
5812418	5215609		12												
5408734	5218675		16												
5408857	5218691		16												
5409090	5218926		17												
5412212	5229960		13												
5629535	5230322		13												
		E													
5415879	5304105		17												

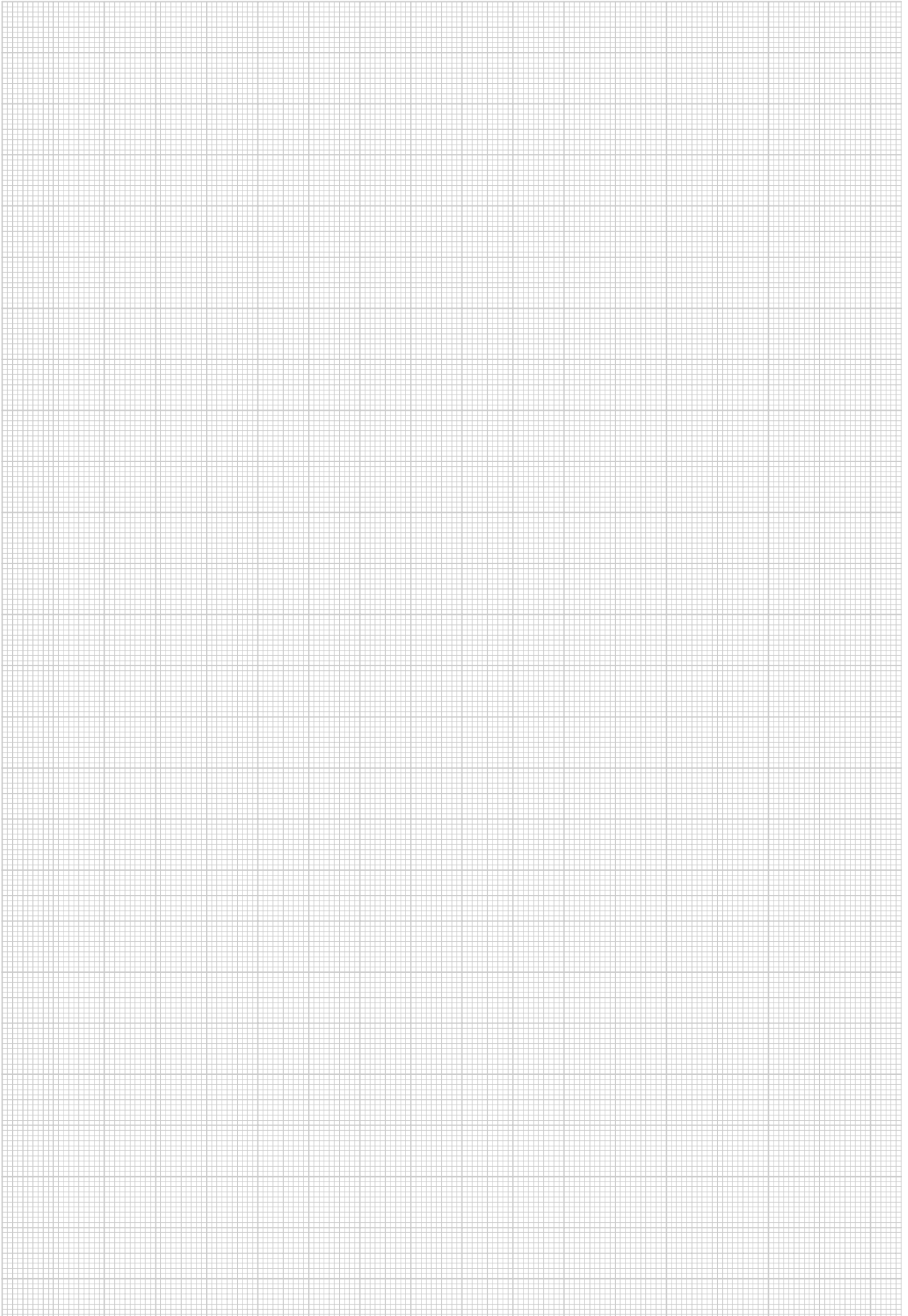

Numerical list by type

Structure of EAN number: country code **40** manufacturer's code **1219** individualised EAN **5647589**

Type	Dimensions	EAN	Order no.	Price	Page	Type	Dimensions	EAN	Order no.	Price	Page
				B						B	
101/ALU	1000 Alu	5901334	5401771		17	288/DIN	Alu	5421634	5320712		16
101/ALU	1500 Alu	5427810	5401801		17						
101/ALU	2000 Alu	5427872	5401836		17	301/S		5426974	5351057		13
101/ALU	2500 Alu	5898399	5401852		17	301/S		5427032	5351073		13
101/ALU	3000 Alu	5902119	5401879		17	301/V		5426790	5350867		13
101/B-16		5897910	5402956		16	301/V-VA		5426912	5350905		13
101/G-DIN	1000 FT	5428053	5402107		12						
101/G-DIN	1500 FT	5428176	5402158		12	303/DIN	FT	5399919	5102081		15
101/ST		5428534	5402891		16	303/DIN	FT	5399971	5102111		15
						303/DIN	FT	5400035	5102138		15
113/B-Z-HD 8-10	Rd 8-10	5629535	5230322		13	303/DIN	FT	5400097	5102154		15
113/B-Z-HD-16	Rd 16	5752356	5412803		14	303/DIN	FT	5400158	5102197		15
113/Z 8-10	Rd 8-10	5412212	5229960		13						
113/Z-16	Rd 16	5429616	5412609		13	324/S		5422419	5326303		13
						324/S-VA		5422471	5326311		13
132/K-Cu	Rd 8-10	5902232	5202590		12						
132/K-VA	Rd 8-10	5403036	5202515		12	356	10	5230533	2360055	E	17
157/FK-VA	Rd 8-10	5902591	5215544		12					B	
157/FK-VA	Rd 8-10	5812296	5215587		12	853/DIN	Alu	5423379	5331013		17
157/FK-VA	Rd 8-10	5812418	5215609		12					E	
157/LK-VA	Rd 8-10	5811879	5215374		12						
						1801 VDE		5378556	5015650		14
165/MBG	Rd 10 PE/PP	5408734	5218675		16	1809		5378259	5015073		14
165/MBG	Rd 8 PE/PP	5408857	5218691		16	1809/A		5959427	5015111		14
						1811	250 FT	5377894	5014018		15
172/AR	Alu	5409090	5218926		17	1813/DIN	FT	5378013	5014212		16
177/20-DIN	Rd 8-10 PA	5404897	5207444		17	1819/20	TG	5242710	3041204		15
177/30-DIN	Rd 8-10 PA	5404958	5207460		17	1819/20BP	TG	5242772	3041212		15
177/B-HD-20	Rd 8-10 PA	5336433	5207851		17						
177/B-HD-30	Rd 8-10 PA	5334811	5207878		17	2760/20		5372912	5001641		15
						2760/20-VA		5752653	5001625		15
200	1500 FT	5429791	5420156		14						
200	2000 FT	5429913	5420202		14	5001/DIN	Rd 8-10	5415879	5304105		17
				E							
219/20	1500	5371298	5000017		15	5052	FT	5380832	5020336		14
219/20 BP	1500	5371892	5000947		15	5052	FT	5381372	5020832		14
219/20 BP-VA	1500	5371830	5000866		15	5052	FT	5381495	5020956		14
						5052/V2A	V2A	5800415	5018501		14
				B		5052/V4A	V4A	5800477	5018706		14
223/DIN	8-10/16	5423614	5335205		13					G	
226	8-10/FL30 x 16	5424215	5336007		13	MC 50-B VDE		5966388	5096847		18
						MC 125-B/NPE		5966449	5096863		18
226/Cu	8-10/FL30 x 16	5424277	5336023		13					E	
226/VA	8-10/FL30 x 16	5424338	5336058		13	RD 8/ALU-T**		5901273	5021294		12
248/VA	Rd 8-10	5417910	5311551		12					G	
249/Alu	Rd 8-10	5417736	5311519		12	V 25-B/0		5394099	5097053		18
249/ST	Rd 8-10	5417675	5311500		12	V 25-B/3 (TN-C)		5808091	5097002		18
						V 25-B/3+NPE		5785590	5097401		18
252/DIN		5418153	5312345		14	V 25-B/4 (TN-S)		5394037	5097037		18
252/DIN		5418092	5312310		14						
				E							
256/A-DIN		5419471	5314658		14						
256/B-A-DIN 30		5925873	5314720		14						
										B	
262		5419891	5316014		12						
262/ZM		5818359	5316170		12						
270		5420552	5317207		16						
274		5420859	5317428		16						
287		5421573	5320704		16						

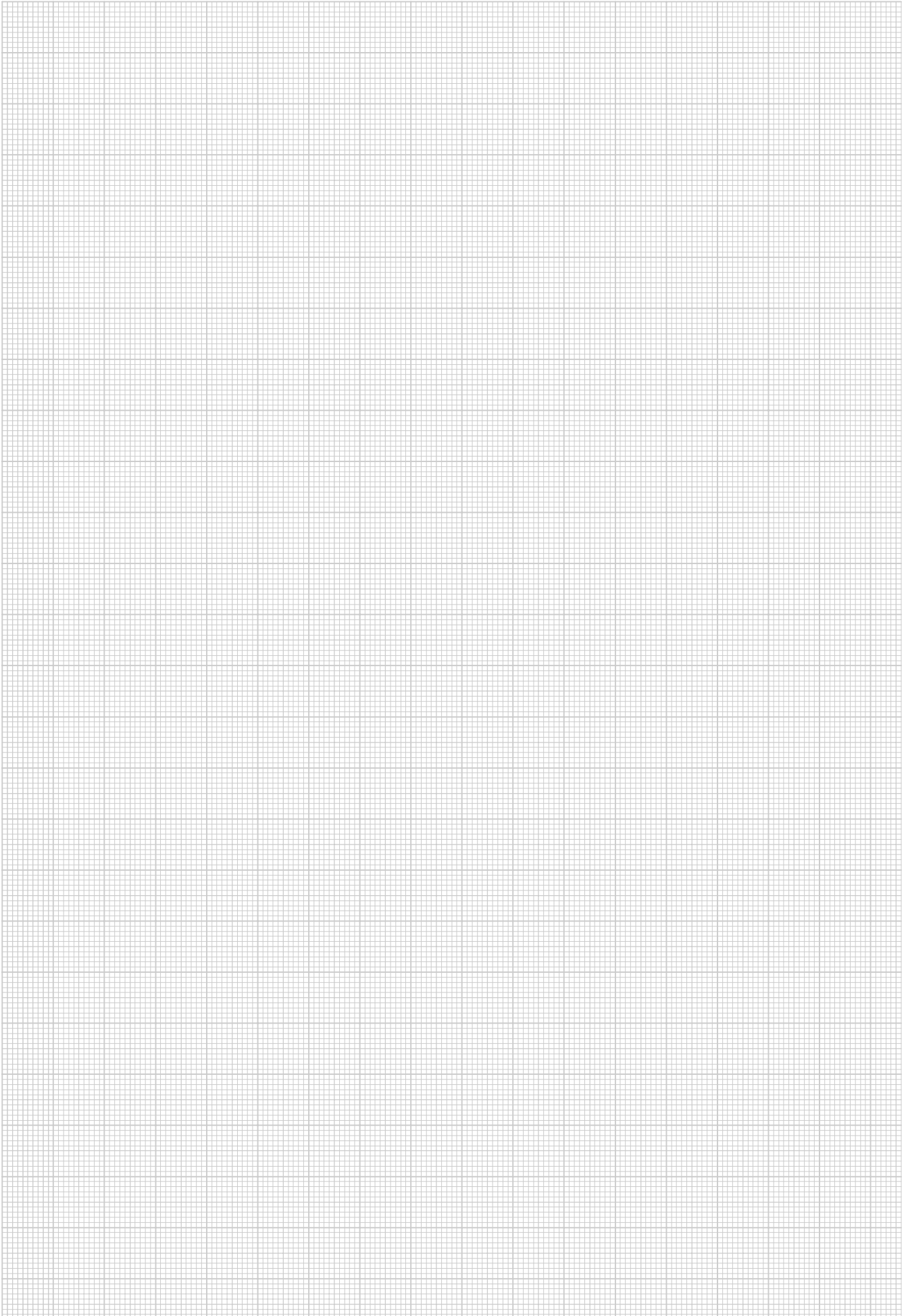

Discount groups

B	Lightning protection components	
E	Electrical installation equipment	
G	Surge protection equipment, chemical items	

Terms and Conditions of Sale and Delivery

OBO BETTERMANN GmbH & Co. KG and OBO BETTERMANN Projekt und Systemtechnik GmbH, Menden

1. All our supplies and services shall be governed exclusively by the following terms and conditions, including our additional terms and conditions for cable tray business transactions. Any terms and conditions of business and purchasing of the customer shall be valid only if we have acknowledged them in writing. Our quotations are without engagement; they are mere invitations to submit contract offers. Any and all transactions and agreements, including those entered into by our employees and agents shall only be binding upon our written confirmation or invoicing. The foregoing provision shall also apply to any modifications of the agreed formal requirements.

2. The documents and data pertaining to the quotation, such as illustrations, brochures, drawings, dimensions, loading capacity values and weight details are approximate only, unless they are expressly stipulated to be binding. Samples are non-binding samples for inspection. Any purchase according to sample will be subject to customary deviations and deviations resulting from normal production processes. The properties of the sample shall be no guaranteed quality of the purchase object unless expressly stated otherwise in the confirmation of order. Samples must be returned to us at the latest within four weeks in perfect condition. If they are not returned within this period in proper condition, we shall be entitled to charge the purchase price for the sample in accordance with our current price list. All information on our products, in particular the illustrations, drawings, weight, dimension and performance data included in our quotations and printed matter shall be regarded as approximate average values and shall not represent any quality guarantee.

With regard to products made according to customer drawings, samples and other instructions of the customer, we will not provide any warranty nor assume any liability for the due and proper functioning of the product or for any other defects if and to the extent they are based upon the customer's specifications. The customer shall indemnify us from any third party claims, including claims for product liability as may be asserted against us for damages resulting from the products unless we have caused such damages by intent or gross negligence. The customer shall warrant that the manufacture and supply of products made in accordance with his instructions will not infringe any proprietary rights of third parties. Should any proprietary rights be asserted against us, we shall be entitled, without any legal review of the third party claims, to withdraw from the contract after hearing the customer, unless the third party withdraws the claims asserted against us under its proprietary rights within eight days by written declaration. The customer shall compensate us for any damage sustained as a result of the assertion of proprietary rights. In case of withdrawal, the work we have carried out so far shall be remunerated. Further rights under the statutory provisions shall not be affected thereby.

Any moulds, tools and design data produced by us for the execution of the order shall be our exclusive property. Unless expressly agreed otherwise, the customer shall not have any claims thereto, even if he has contributed to the costs of producing any such moulds, tools and design data.

3. The packing, shipping route and means of transportation shall be left to our discretion in the absence of any other agreements. They shall be charged at their cost price. We will take back undamaged cases, when being returned carriage paid, at 2/3 of the amount invoiced. The one-way or pool pallets used for transport shall be either exchanged upon taking delivery or returned. The smallest packing units stocked and listed may not be broken up for rationalisation reasons. In case of orders for different quantities, the nearest packing unit will be supplied.

We reserve the right to deviate from the agreed delivery quantity, in particular in the case of custom-made products, to a customary extent or in conformity with national or international standards. In case of a demand for adhering to a precise quantity, an express reference is necessary and subject to confirmation.

Master and call orders shall oblige the customer to accept the total quantity on which the master/call order is based. Where no particular call orders are specified in the contract, the total quantity of the master call order must be called within twelve months. If the customer fails to adhere to call deadlines, we shall be entitled to deliver and charge the total quantity in full after four weeks from written notice with reference to the consequences of any failure to call. Our rights arising from any default of the customer shall not be affected thereby.

4. Unless otherwise agreed, our prices are quoted ex works and do not include packing and insurance. The value added tax at the rate applicable on the date of dispatch will be added to our prices. The purchaser shall ensure the correctness of his VAT identification number, which he must notify to us immediately without being asked. He shall undertake to inform both us and the competent domestic tax authority without delay of any change in his name, address and VAT identification number.

Delivery shall be franco domicile within Germany, i.e. carriage and packing prepaid, if the net order value is in excess of € 1,200. For small orders below € 100 (net including value added tax), we shall invoice a lower quantity surcharge of € 10 (net) per order. Upon transfer of our supplies and services to a carrier or forwarding agent, at the latest upon their leaving our warehouse or supply plant, the risk shall pass to the recipient, even in case of deliveries free place of destination.

5. Delivery periods and delivery deadlines shall be approximate only unless we have expressly stated in writing that they are binding. Delivery periods shall commence upon receipt of our confirmation of order, but not before clarification of all execution details, ex place of delivery. The customer shall only be entitled to withdraw from the contract after having granted a reasonable extension of time. We reserve the right to make partial deliveries. Claims for damages and reimbursement of expenses - for any reason whatsoever - shall be subject to the provisions set out in article 10.

In the event of any circumstances that are beyond our control within the scope of normal operating risks and obstruct or make impracticable any delivery, we shall be entitled to suspend delivery by the duration of such obstruction plus a reasonable start-up period or to withdraw from the contract for the part not yet fulfilled. The purchaser can demand a statement from us as to whether we wish to deliver within a reasonable period or withdraw. If we fail to make such a statement, the purchaser may withdraw. Our notice to the purchaser shall be deemed to be sufficient evidence that we have been prevented from delivering.

6. Payments shall be made upon receipt of invoice less a 3% cash discount for payment within 10 days or net after 30 days from date of invoice. Erection work and all paid labour work must be paid within 10 days without deduction of any cash discount. In case of non-cash payments, the date of the credit note will be deemed to be the date of receipt of payment. Payments received shall always be credited first against costs, then against interest and then against the earliest liability. Cheques and bills of exchange shall only be accepted as means of payment. Any payment by bill of exchange shall be subject to a prior separate and written agreement, whereby all bill costs shall be borne by the customer and no discount can be granted. The customer shall have no right to refuse performance and no right of retention - for any legal reason whatsoever - unless we have acknowledged his claim beforehand in writing or his claim has the force of law.

The customer shall only be entitled to set off claims which have the force of law, are undisputed or acknowledged by us in writing.

7. We shall retain title to the goods supplied by us until all our claims arising from our business transactions with the customer have been satisfied - current account clause - and all bills of exchange or cheques submitted for payment by the customer have been honoured.

Any treatment or processing of goods subject to our retention of title (reserved goods) shall be carried out for us as the manufacturer in accordance with § 950 BGB (German Civil Code) without any obligation on our part. If our reserved goods are to be regarded as the main item or the main item is owned by the customer, full title to the new item shall pass to us when it is created. In other cases, we shall acquire a co-ownership interest in the new item in the proportion of the sales value of our reserved goods to the other goods used for the new item at the time of processing, intermingling, joining or mixing. The customer shall take custody of our ownership or co-ownership interest free of charge; it shall be treated as reserved goods.

Before transfer of title, our goods shall be neither pledged nor assigned as collateral without our prior consent. In addition, any third party rights or pledges shall be notified to us immediately and we shall be given all details and provided all documents necessary for intervention; otherwise the customer must bear our loss. In the latter case, our total claims against the customer shall also be immediately payable.

The customer shall be entitled to sell or to use our reserved goods in the ordinary course of business subject to the condition that the relevant claims are transferred in accordance with article 8 below. This right shall lapse upon the customer's failure to promptly meet his payment obligations towards us or in the event of any cheque or bill protests or his suspension of payments. In such cases, we shall be entitled to take back the goods provisionally at the

customer's expense and to sell them at our duly exercised discretion after a corresponding reminder has been sent to the customer. We will then pass the due amount to the customer's credit.

8. If our goods are sold before payment of our claim, the customer shall be obliged to retain our title against his purchaser until the goods have been paid for in full by the purchaser. The claim arising against the purchaser from such resale as well as any other ancillary rights or security interests of the customer resulting from the sale and any claims for compensation in case of damage to or destruction of our reserved property, including the relevant insurance sum shall hereby be assigned to us. We hereby accept this assignment. Where our co-ownership interest is sold, the relevant claims shall be assigned in the amount corresponding to the value of our interest.

The customer shall, at our request, inform us of his purchasers, notify them of the assignment made and provide us with any and all documents required to assert our rights.

As long as the customer meets his contractual obligations without delay, he shall be authorised to collect the claims assigned. He shall keep the amounts collected on our behalf separately and remit them to us immediately as soon and as far as our claims become due. The authorisation shall lapse in case of any cheque or bill protest of the customer or his definite suspension of payments. The customer shall bear the costs incurred for any action taken against third parties and shall advance them upon request.

If the security provided to us by the retention of title and the anticipatory assignment should exceed the claims to be secured by more than 20%, we shall, at the customer's request, release paid supplies of our choice. Upon payment of all our claims by the customer, assigned claims shall pass to the customer.

9. Any complaints for obvious defects regarding the quantity or quality of our supplies and services that are identifiable upon careful inspection shall without delay, but at the latest within the period of limitation of eight days from arrival of the goods at the address of the customer or the person appointed by him, be notified in writing to us, not to our representatives. Slight deviations in dimensions and designs within the scope of defined technical tolerances shall not give rise to any right of complaint. Any rejected goods may only be returned to us with our prior written authorisation.

In case of justified complaints within the prescribed period, we shall, at our option, take remedial action by way of subsequent performance, by rectifying the defect, supplying non-defective goods or providing a credit note for the lower value calculated.

We shall be entitled to refuse subsequent performance in accordance with the statutory provisions. If our subsequent performance, if any subsequent performance remains unsuccessful or if the customer cannot be reasonably expected to accept any subsequent performance, the latter shall be entitled to withdraw from the contract in compliance with the provisions of the following sentences. The customer shall only be entitled to withdraw from the contract - where a withdrawal is not excluded by law - upon the unsuccessful expiry of a reasonable period for subsequent performance set by him, unless this period was not required under the statutory provisions (§§ 281 para. 2, 323 para. 2, 440, 441 para. 1 BGB (German Civil Code)).

In case of his withdrawal, the customer shall be liable for any deterioration, destruction or loss of use resulting from any negligence or intent on his part. Any claims for damages or reimbursement of expenses of the customer shall be subject to the provisions set out in article 10.

In the case of any fraudulent concealment of a defect or in the case of any provision of a quality guarantee for the goods sold at the time of the passing of risk within the meaning of § 444 BGB (German Civil Code) (seller's declaration that the object sold has a specific property at the time of the passing of risk and that the seller, regardless of any fault on his part, intends to be answerable for any and all consequences resulting from its absence), the customer's rights shall be exclusively governed by the statutory provisions.

We shall - in addition to the statutory grounds for refusal - also be entitled to refuse subsequent performance if and as long as the customer fails to send us, at our request, the rejected goods or a sample thereof; the customer shall have no right of withdrawal for any such refusal. We may further refuse any subsequent performance if the goods concerned have been altered or modified without our consent unless the customer can prove that the defect was not caused by such alteration or modification.

The limitation period for any claims arising from defects shall be one year; in the case of goods which have been used in accordance with their intended purpose for a building and have caused its defectiveness, the limitation period shall be two years. The provisions of §§ 478, 479 BGB (German Civil Code) on recourse in the chain of suppliers shall not be affected thereby.

10. In the case of a pre-contractual, contractual or non-contractual breach of duty, including unsatisfactory delivery, tortious conduct and producer's liability, we shall only be liable for compensatory damages and reimbursement of expenses - subject to further contractual or statutory liability requirements - in the case of intent, gross negligence or slightly negligent breach of a material contractual duty (contractual duty the infringement of which jeopardises the fulfilment of the object of the contract). However - except in the case of intent - our liability shall be limited to the typical contractual damage that was foreseeable at the time the contract was entered into. The purchaser shall not be permitted to make a claim for expenses incurred in vain.

Except for any breach of material duties, our liability for slight negligence shall be excluded, but in any case be limited to the amount of the purchase price.

Any claim asserted by the customer or a third party for payment of a contractual penalty shall be excluded.

With regard to damages caused by delay, we shall only be liable for slight negligence up to the amount of 5% of the purchase price agreed with us.

The exclusions and limitations of liability set forth above shall not apply in the event that a guarantee is given with respect to the quality of the object sold within the meaning of § 444 BGB (German Civil Code) if a defect is fraudulently concealed or in the event of injury to life, physical injury or injury to health, or strict liability under the German Product Liability Act.

Any and all claims for damages against us, for any legal reason whatsoever, shall become statute-barred at the latest after one year from delivery of the goods to the customer, in the case of tortious liability from the time of knowledge, or grossly negligent ignorance, of the circumstances giving rise to the claim and the person liable to pay damages. This provision shall not apply in the case of liability for intent and in the event that a guarantee is given for the quality of the object sold, in the case of fraudulent concealment of a defect or in the event of injury to life, physical injury or injury to health, or strict liability under the German Product Liability Act. Any shorter limitation periods shall take precedence.

11. We shall be entitled to process and store any customer data obtained with regard to or in connection with the business relationship in accordance with the German Federal Data Protection Act, irrespective of whether such data is provided by the purchaser himself or by any third parties.

12. Place of performance for delivery and payment is Menden/Sauerland. The court of competent jurisdiction for any and all disputes, including disputes with regard to bills of exchange and cheques, is the Local Court (Amtsgericht) of Menden or, at our option, the District Court (Landgericht) of Arnsberg, irrespective of the value of the object in dispute. We shall, however, also be entitled to take legal proceedings against the customer at the place of his registered office.

German law shall be exclusively applicable. The application of international purchase laws is hereby excluded.





Should, for any reason whatsoever, individual provisions of our terms and conditions of sale and delivery be invalid, the validity and binding nature of the other provisions shall not be affected thereby. The customer agrees that the invalid provision shall be replaced by a valid provision that comes as close as possible to the economic meaning of the invalid provision.

13. The prices of products made of brass and copper are subject to certain fluctuations that are based on the relevant DEL listings. The prices of our brass articles are based on a DEL listing of € 150 for Ms 58, those of our copper products on a DEL value for electrolyte copper of € 200.

In case of any increase or reduction in these prices by more than € 15, a five per cent surcharge or deduction shall be made for each 15 points. The calculation of any such surcharges or deductions shall be based on the DEL listing of the date of our receipt of the order.

Valid from April 2002

OBO-System overview

<p>VBS Connection and fastening systems</p>		<p>Connection systems Fastening systems Beam clamp systems Rail systems Screw-in and knock-in systems</p>
<p>VBS Connection and fastening systems</p>		<p>Earthing systems Equipotential bonding systems Lightning protection systems Surge protection systems</p>
<p>KTS Cable support systems</p>		<p>Installation systems Cable tray systems Mesh cable tray systems Cable ladder systems Vertical ladder systems Lighting support systems Modular systems Distribution boxes Stainless steel components</p>
<p>BSS Fire protection systems</p>		<p>Cable insulation Function maintenance BSK fire protection ducts</p>
<p>LFS Cable routing systems</p>		<p>Installation trunking systems Skirting trunking systems IBIS Integral</p>
<p>UFS Underfloor distribution systems</p>		<p>Underfloor distribution systems</p>