

Basic schematic

FDB-3...

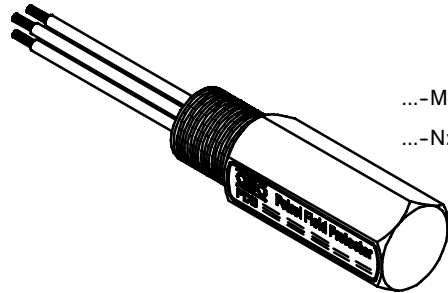

...-M: metric
...-N: NPT 1/2"

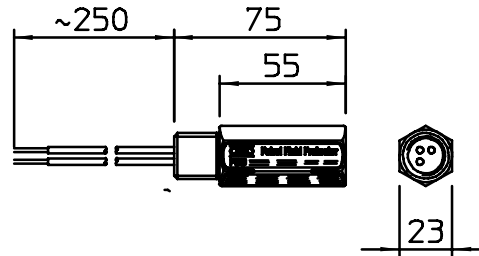

Application example

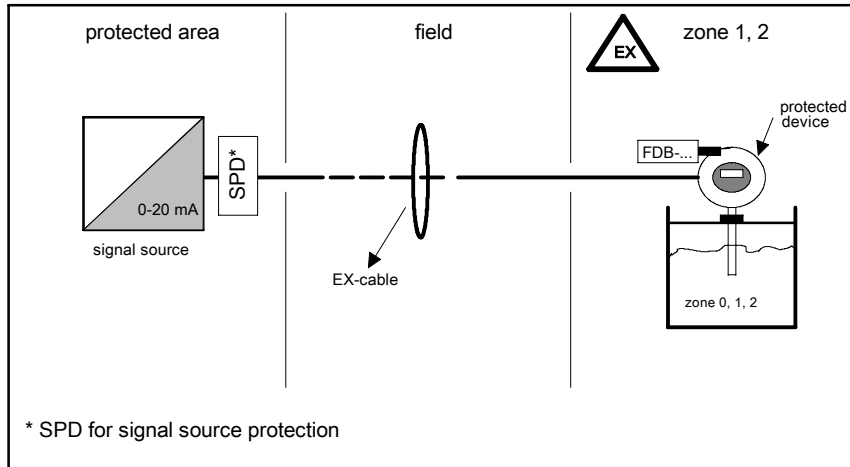

Wire map

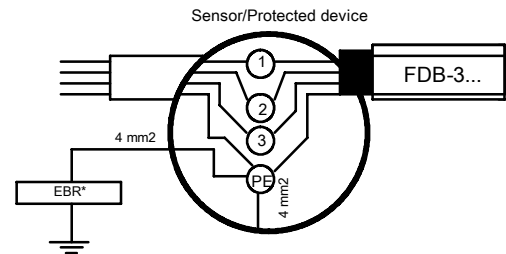

*EBR for equipotential bonding rail

Technical Data

U max. AC	22 V
U max. DC	32 V
Discharge current C2 (total)	10 kA
Discharge current C2 (line-line)	0,25 kA
Protection level line/earth	< 800 V
Protection level line/line	< 80 V
Temperature range	- 20 - + 70 °C
Capacity (line-line)	< 17 pF
Capacity (line-earth)	< 26 pF
Installation input/output	M20 x 1,5 external thread (metric)
Installation input/output	1/2" NPT, external thread (NPT)
Installation field/device	Connection line 1,5 mm ² , length 250 mm
Earthing	Connection line
Housing material	V2A
Certification	ATEX



Standards:
EN 60079-25
EN 60079-11
IEC 61643-21

Ex-certification: BVS 10 ATEX E 048



EX-Specifications

$U_i = 32$ V
 $P_i = 4$ W
 $I_i = 500$ mA
 C_i negligibly small
 L_i negligibly small

Tested conform ATEX by DEKRA EXAM

Ex-certification: BVS 10 ATEX E 048

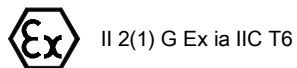

Protection circuit

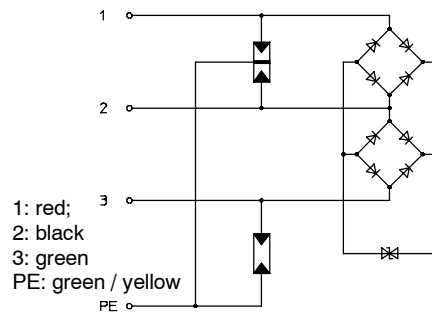

Electrical test

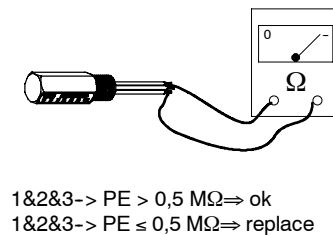

Head Office OBO BETTERMANN GmbH & Co. KG
Postfach 1120 · 58694 Menden, Germany
Hüngser Ring 52 · D-58710 Menden
Tel. +49 (0)2373-89-0 Fax +49 (0)2373-89-238
E-Mail: info@obo.de · www.obo-bettermann.com

Technical Hotline
Telefon +49 (0)2373/89-1500
Telefax +49 (0)2373/89-1550
E-Mail hotline@obo.de

Basic schematic

FDB-2...

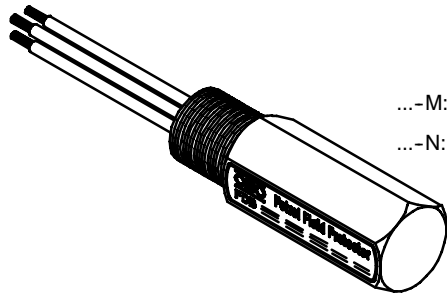

...-M: metric
...-N: NPT 1/2"

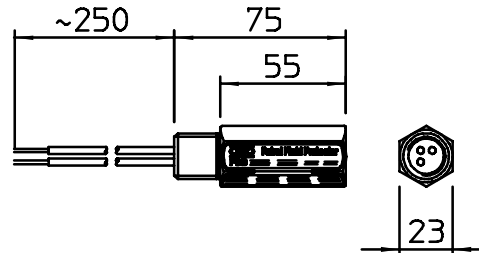

Technical Data

U max. AC	22 V
U max. DC	32 V
Discharge current C2 (total)	10 kA
Discharge current C2 (line-line)	0,25 kA
Protection level line/earth	< 800 V
Protection level line/line	< 80 V
Temperature range	- 20 - + 70 °C
Capacity (line-line)	< 17 pF
Capacity (line-earth)	< 26 pF
Installation input/output	M20 x 1,5 external thread (metric)
Installation input/output	1/2" NPT, external thread (NPT)
Installation field/device	Connection line 1,5 mm ² , length 250 mm
Earthing	Connection line
Housing material	V2A
Certification	ATEX

Application example

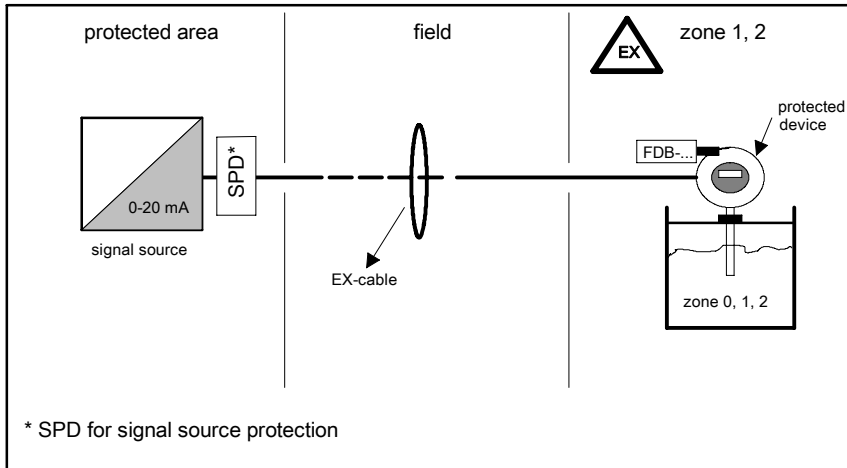

Wire map

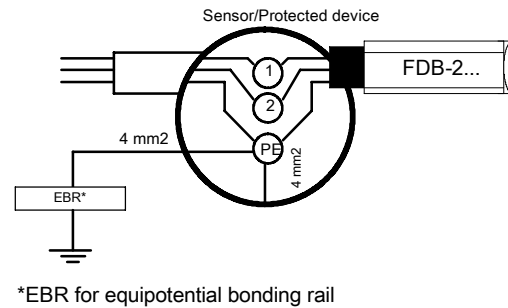

Standards:
EN 60079-25
EN 60079-11
IEC 61643-21

Ex-certification: BVS 10 ATEX E 048



EX-Specifications

$U_i = 32$ V
 $P_i = 4$ W
 $I_i = 500$ mA
 C_i negligibly small
 L_i negligibly small

Tested conform ATEX by DEKRA EXAM

Ex-certification: BVS 10 ATEX E 048

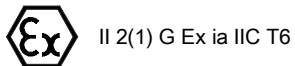

Protection circuit

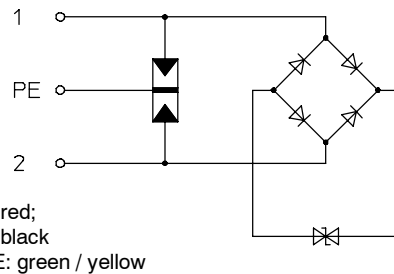

Electrical test

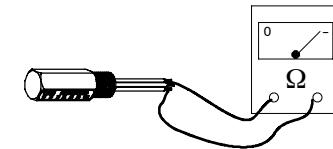

1&2-> PE > 0,5 MΩ ⇒ ok
1&2-> PE ≤ 0,5 MΩ ⇒ replace



Head Office OBO BETTERMANN GmbH & Co. KG
Postfach 1120 · 58694 Menden, Germany
Hüngser Ring 52 · D-58710 Menden
Tel. +49 (0)2373-89-0 Fax +49 (0)2373-89-238
E-Mail: info@obo.de · www.obo-bettermann.com

Technical Hotline
Telefon +49 (0)2373/89-1500
Telefax +49 (0)2373/89-1550
E-Mail hotline@obo.de

Sicherheitshinweise

Die Montage sowie der Anschluss dieses Überspannungsschutzgerätes darf nur durch eine Elektrofachkraft erfolgen. Es gelten die jeweiligen nationalen Vorschriften und Sicherheitsbestimmungen.

Vor der Installation ist das Gerät auf äußere Beschädigung hin zu überprüfen.

Sollte eine Beschädigung festgestellt sein oder ein sonstiger Mangel festgestellt werden, darf das Gerät nicht installiert werden

Der Einsatz dieses Gerätes ist nur nach der in dieser Montageanleitung aufgeführten Anwendung zulässig. Bei Belastungen über den angegebene Werten kann das Gerät und die jeweilige Endgeräte zerstört werden.

Bei Veränderungen oder Eingriffen am Gerät erlischt die Gewährleistung.

Besondere Bedingungen

Dieses Überspannungsschutzgerät kann nach Herstellerangaben in den Zonen 1 bzw. 2 eingesetzt werden. Der Sensorstromkreis darf in die Zone 0 eingeführt werden, welches der Bezeichnung II 2 (1) G entspricht.

Alle metallischen Teile im explosionsgefährdeten Bereich müssen in den Potentialausgleich eingebunden werden. Die auszuführende Verbindung zwischen dem Gehäuse des Endgerätes und der örtlichen Masse muß mit mindestens 4mm² ausgeführt werden.

Montage:

Wird das Gerät in druckfeste Gehäuse eingebaut, in eine Mindesteingriff von 5 Gewindegängen zu berücksichtigen! Ein Verdrehenschutz, sowie die IP-Schutzart muss mit geeigneten Maßnahmen gewährleistet werden. Dies kann durch Folgende Maßnahmen erfolgen:

Einsatz von Kontermuttern mit Dichtung
Einsatz von Loctite mittelfest in den Gewindebohrungen

Bei der Montage sind die Anforderungen der EN 60079-11 bezüglich der Trennung zu nicht-eigensicheren Stromkreisen zu beachten.

Anschluss:

Der Anschluß des Petrol Field Protectors darf nur im spannungsfreien Zustand erfolgen! Der Potentialausgleich ist durch die Art des Anbaus sicherzustellen!

Safety instructions

The device may only be connected and installed by an electrically skilled person.

National standards and safety regulations must be observed.

The device must be checked for external damage prior to installation. If any damage or other faults are detected in this check, the device must not be installed.

Its use is only permitted within the limits shown and stated in these installation instruction. Wrong installation and / or to high loads can destroy the device.

Opening the device or otherwise tampering with the surge protection device invalidates the warranty.

Special conditions:

According to the manufacturer, this equipment can be used in zone 1 and / or zone 2.

The sensor circuit may be let into zone 0. This corresponds to description II 2(1) G.

All metal parts within the explosive zone have to be connected to the equipotential bonding.

The connections between the enclosure of the terminal equipment and the local earth must provide a minimum cross section of 4mm².

Installation:

For installation into a flameproof enclosure, min. 5 threads must be engaged. The protection against twisting and degree of protection (IP) has to be ensured by taking corresponding measures. This can be achieved by using lock nuts with sealing or using Loctite (with medium strength) within the threaded holes.

When assembling, the requirements of the EN 60079-11 are to be considered concerning the separation to non-intrinsically safe electric circuits.

Connection:

The Petrol Field Protector (FDB...) may be connected under dead connections only.

The kind of installation of the device must ensure the equipotential bonding!



Translation

EC-Type Examination Certificate

- (1)
- (2) - Directive 94/9/EC -
Equipment and protective systems intended for use
in potentially explosive atmospheres

(3) **BVS 10 ATEX E 048**

(4) **Equipment:** Surge protective device type FDB-*74-*

(5) **Manufacturer:** OBO Bettermann GmbH & Co.

(6) **Address:** 58694 Menden, Germany

(7) The design and construction of this equipment and any acceptable variation thereof are specified in the appendix to this type examination certificate.

(8) The certification body of DEKRA EXAM GmbH, notified body no. 0158 in accordance with Article 9 of the Directive 94/9/EC of the European Parliament and the Council of 23 March 1994, certifies that this equipment has been found to comply with the Essential Health and Safety Requirements relating to the design and construction of equipment and protective systems intended for use in potentially explosive atmospheres, given in Annex II to the Directive.
The examination and test results are recorded in the test and assessment report BVS PP 10.2102 EG.

(9) The Essential Health and Safety Requirements are assured by compliance with:

EN 60079-0:2006 General requirements
EN 60079-11:2007 Intrinsic safety 'i'
EN 60079-25:2004 Intrinsically safe systems

(10) If the sign "X" is placed after the certificate number, it indicates that the equipment is subject to special conditions for safe use specified in the appendix to this certificate.

(11) This EC-Type Examination Certificate relates only to the design, examination and tests of the specified equipment in accordance to Directive 94/9/EC.
Further requirements of the Directive apply to the manufacturing process and supply of this equipment. These are not covered by this certificate.

(12) The marking of the equipment shall include the following:



DEKRA EXAM GmbH

Bochum, dated 07. April 2010

Signed: Hans Christian Simanski Signed: Ralf Leienhecker

Certification body

Special services unit

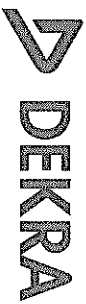

(13)

Appendix to

(14)

EC-Type Examination Certificate

BVS 10 ATEX E 048

(15)

15.1 Subject and type

Surge protective device type FDB-*/24-*

The first asterisk will be substituted by the digit 2 or 3. This is the number of conductors beside the protecting Earth.

The second asterisk is substituted by the character M or N and identifies the type of threading (M=Metric and N=NPT).

15.2 Description

The surge protective device, mounted in zone I, is screwed into housings. It protects intrinsically safe circuits against overvoltage.

In terms of the type of protection Intrinsic Safety "i" the intrinsic safe circuits are galvanically isolated from protective ground.

The construction of the overvoltage protector is suitable to be mounted into threaded holes of housings with type of protection "d" flameproof enclosure or "e" increased safety, when securely mounted and sealed.

15.3 Parameters

Maximum input voltage	Ui	DC	32	V
Maximum input current	Ii		500	mA
Internal capacitance	ci		negligible	
Internal inductance	Li		negligible	

(16)

Test and assessment report

BVS PP 10.2102 EG as of 07.04.2010

(17)

Special conditions for safe use

None

We confirm the correctness of the translation from the German original.

In the case of arbitration only the German wording shall be valid and binding.

44809 Bochum, 07. April 2010

BVS-WHKW A 20100145

DEKRA EXAM GmbH

Certification body

Special services unit